

## BHMA TYPE 1

### Rim Exit Device

For Wood & Hollow Steel Doors

**3700 Series**   
FIRE-RATED

**8700 Series**  
LIFE-SAFETY

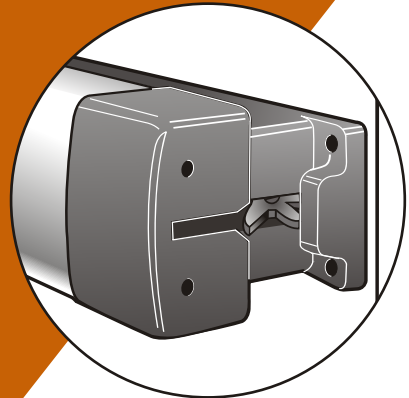

### Features:

- ▼ Patented "Starwheel" Bolt interlocks door to frame
- ▼ Pushbar is anodized or clad, not plated, in a variety of finishes
- ▼ Easy to install
- ▼ Unobtrusive design for clean sight lines
- ▼ Strong, durable construction for a high level of security

### CERTIFICATIONS:

**8700 SERIES:**  
 Life-Safety Listing  
ANSI/BHMA A156.3 Grade 1  
California State Fire Marshall  
New York City MEA\*  
\*Consult factory for specific number

**3700 SERIES:**   
 10C Fire Label, up to 3 hrs.  
California State Fire Marshall  
New York City MEA\*  
Warnock/Hersey Listing for  
Fire Doors up to 10 Feet.  
4'x10' Singles, 8'x10' Pairs.



# Features & Dimensions

## Rim Exit Device

**ANSI/BHMA**  
Grade 1

**Handing**

Device is non-handed. Lever Entry Trim is field reversible.

**Pushbar Length**

Standard Sizes: Dimensioned for 30", 36", 42" & 48" openings. Standard width bars can be field cut to the next smallest opening width.

**Door Thickness**

Suits 1-3/4" standard, up to 2-1/4".

**Stile Width**

3700 - Minimum 3-3/4"\*  
8700 - Minimum 3-3/4"

\*Door construction may require additional stile width to meet fire ratings and provide adequate strength.

**Projection**

2-5/8" when fully projected,  
1-5/8" when dogged.

**Materials**

Pushbar made of extruded aluminum, clad or anodized in a variety of finishes.

**Dogging**

Standard dogging with hex key or optional cylinder dogging for 8700 Series only. Electric dogging also available for 3700 and 8700 Series.

**Fasteners**

Standard self-tapping screws. Optional Sex Bolt Kits - 26-0584 (2 required per device) Specify finish.

**Strike**

Made of hardened steel. Supplied with exit device.

**Cylinders** (order separately)

**Cylinder x Fixed Pull:**

(Functions 03)  
Accepts any standard Rim cylinder.

**Entry Lever or Thumbturn:**

(Functions 08, 09, 11, 12)  
Accepts any standard diameter Mortise cylinder with MS® cam. Accommodates cylinder lengths from 1" to 1-1/4".

**Warranty**

Five year limited.

**AVAILABLE FINISHES**

- 313** Dark Bronze Anodized
- 335** Black Anodized
- 628** Clear Anodized
- US3** Bright Brass
- US4** Satin Brass
- US9** Bright Bronze
- US10** Satin Bronze
- 10B** Dark Bronze (Trim only)
- US32** Bright Stainless
- US32D** Satin Stainless

*Consult factory for special finishes.*

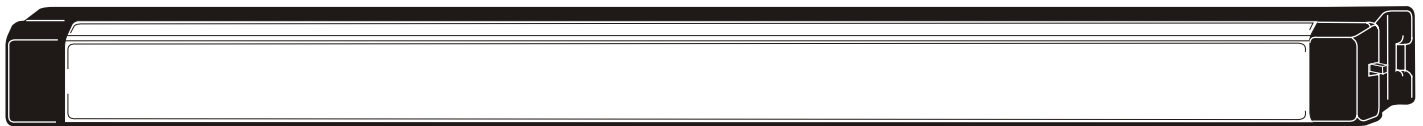

**Starwheel Bolt**

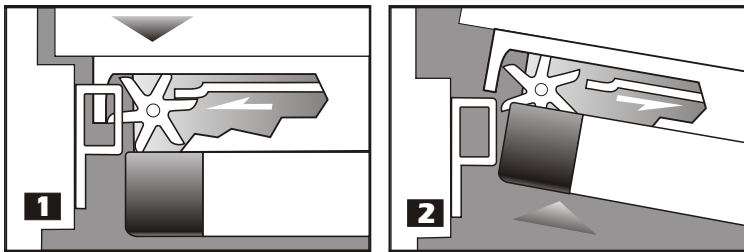

[1] When door closes, the interlocking noseguard and Starwheel bolt close around the strike. The deadlocking slide springs over, locking the Starwheel bolt to the strike. [2] When pushbar is depressed, the deadlocking slide moves back, allowing the door to unlock from the strike. This unique interlock provides solid security and prevents jamb spreading.

**Strike**

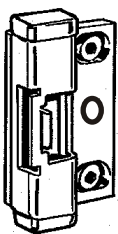

Standard hardened steel strike (Included)

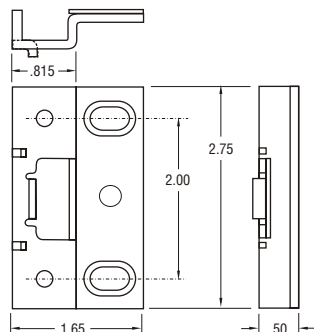

**Pushbar Dimensions**

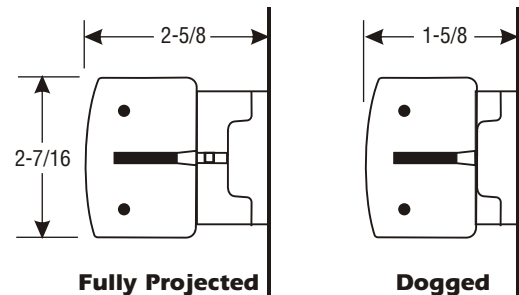

**Removable Mullion - 3889** 🔥

Allows the use of Rim exit devices on paired doors without narrowing the doors. Provides higher security and better traffic flow than paired doors with Vertical Rod exit devices. The 3889 is used for fire-rated applications or with non-rated devices on wood or hollow metal doors. Available in primer only. Specify door height when ordering.

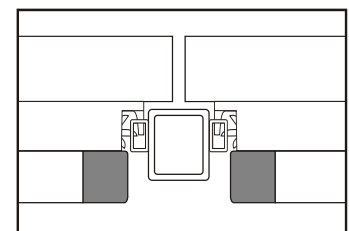
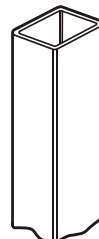

# Trim & Function

## Rim Exit Device

### ANSI/BHMA Functions:

01	02	03	08	09	11	12	14
EXIT ONLY- NO TRIM	PULL ONLY WHEN DOGGED <b>DUMMY TRIM</b>	KEY RETRACTS LATCHBOLT <b>NL</b>	KEY LOCKS LEVER	KEY LOCKS LEVER <b>NL</b>	KEY LOCKS THUMBTURN <b>8700 ONLY</b>	KEY LOCKS THUMBTURN <b>NL</b> <b>8700 ONLY</b>	PASSAGE SET
<b>CYLINDER TYPE</b>							
N/A	N/A	<b>RIM</b>	<b>MORTISE</b>	<b>MORTISE</b>	<b>MORTISE</b>	<b>MORTISE</b>	N/A

**NL** – Night Latch

### Clutch Lever Entry Trim

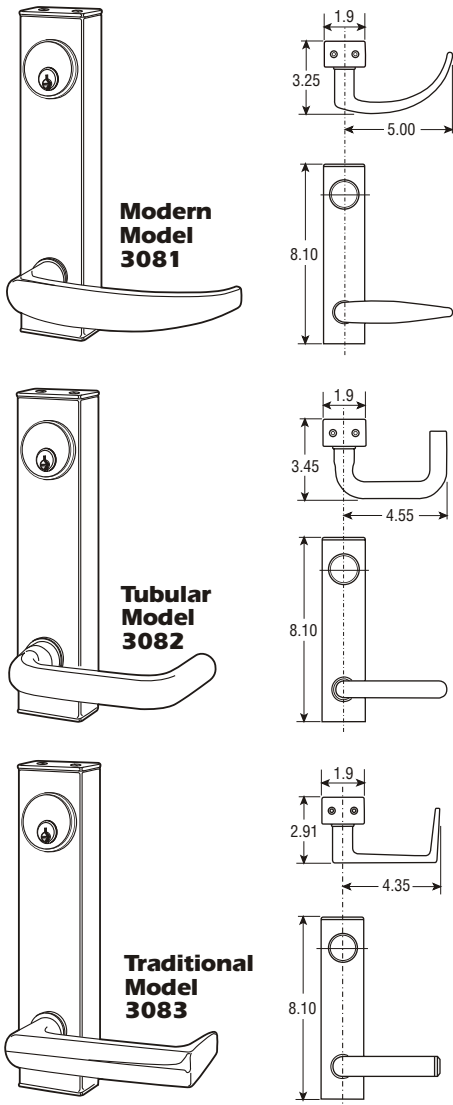

### Fixed Pulls (US32 only)

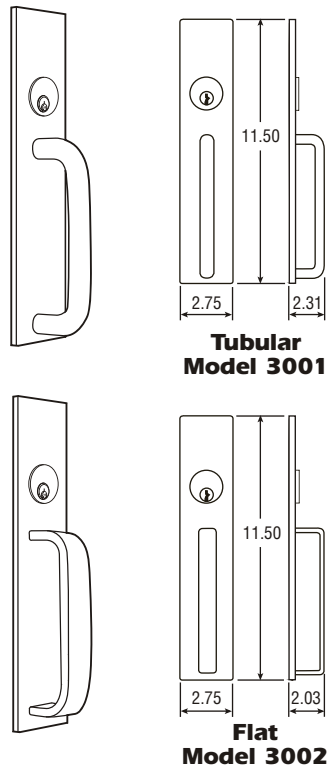

### Thumbturn

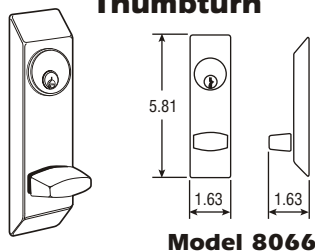

### Rim Cylinder

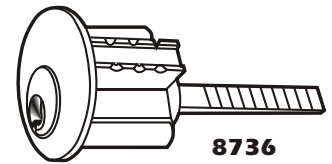

Standard five-pin unit with spindle to suit Rim exit devices. All brass with same choices of keying as Mortise cylinder. Available in finishes 628, 313 or 335. Any other make standard Rim cylinder can be used to key in with existing systems. Note that if entry trim is specified for cylinder use, the cylinder must be Mortise type, regardless of exit device.

### Mortise Cylinder

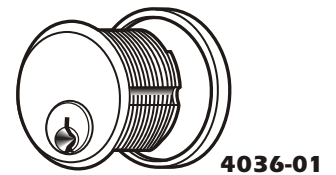

Standard diameter five-pin unit with MS® cam, suitable for use with Entry Trim on Rim exit devices. All brass construction with front "scalp" available in finishes 628, 313 and 335. Available in quantity all keyed different (KD), in pairs (KA2) or fifty alike (KA50). Any other make standard Mortise cylinder with MS® cam can be used to "key in" with existing systems.



# Options & Accessories

## Rim Exit Device

Order by adding suffix to Exit Device in place of hyphen or by separate model number.

### MONITOR/SIGNAL SWITCH

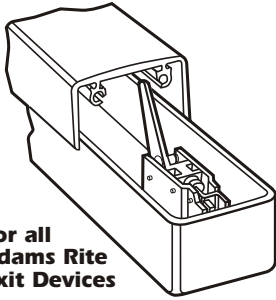

For all Adams Rite Exit Devices

**M1 - Single Switch**  
**M2 - Dual Switch**

A switch in the exit device pushbar mounted on the hinge end. Switch can be used to activate signal light, horn, monitor or other devices. Most common application is to release maglock when pushbar is depressed. Switch can be wired for normally open or normally closed depending upon application. Can be retrofit in field to existing exit device. Dual switch version offers redundancy as required by some building codes or the option of operating a second signaling device.

Specify by adding "M1" or "M2" after exit device model number.

Monitor Kits for upgrading any 3000 or 8000 Series device:  
91-0897-01 - Single Switch      91-0897-02 - Dual Switch

### ELECTRIC LATCH RETRACTION

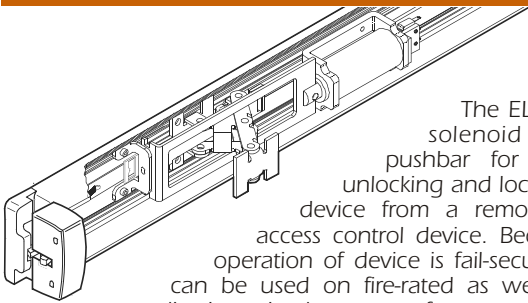

The EL option uses a solenoid mounted in pushbar for instantaneous unlocking and locking of the exit device from a remote location or access control device. Because electrical operation of device is fail-secure, this option can be used on fire-rated as well as life-safety applications. In the event of a power failure device automatically relocks. Rim devices are available in 12 or 24 VDC and can be powered with a simple transformer and rectifier or other DC power supply.

Specify by adding "EL" after exit device model number. Also specify 12 or 24 volt.

#### Solenoid Specifications:

EL-12 VDC - 1.5 Amps Inrush/Hold

EL-24 VDC - .6 Amps Inrush/Hold

Solenoids are rated for both intermittent and continuous operation. Specify for optional hex key dogging. Also see 4612 Power Transfer.

### MONITORED DUMMY PUSHBAR

**8099M1 - Single Switch**  
**8099M2 - Dual Switch**  
**8099-00 - Dummy Only**



Dummy pushbar with no latch mechanism but with either a single or dual monitor/signal switch. Most common application is in conjunction with a maglock where bar is used to turn off magnet and allow exit from building. Dual switch version allows redundancy where required by code or the operation of a signal device along with maglock. Specify door type and width when ordering. Available in all exit device finishes.

The 8099-00 is also available as a non-operating dummy for doors not requiring an exit device, but where matching trim is desired. Specify door type, opening width and finish to be matched.

### ALARMED EXIT DEVICE



For all Adams Rite Exit Devices

This option emits a loud alarm to notify management of unauthorized exit. Will not alter the Life-Safety characteristics of the exit device in any way. Control of the alarm is by use of a key in any standard Mortise cylinder with MS® cam to arm, disarm, delay or reset the alarm. Red letters on the bar give a "hands off" warning to deter accidental actuation.

#### Battery Operated Alarm

Four AA alkaline batteries power twin horns to create a piercing 95 decibel noise for two minutes (or until disarmed) when pushbar is depressed. Beeps to signal need for new batteries.

#### Hardwired Alarm

Can be connected to external horn for louder or remote signal. Remote monitor LED light can also be wired in, as can a door position proximity switch. Also accommodates an external delay switch, such as an outside key switch or pad, to allow authorized entry. Uses rechargeable nicad batteries connected to 12-24 Volt AC or DC source. Each bar has its own battery backup system.

Minimum opening width: 36"

### CYLINDER DOGGING

For all non-rated Adams Rite Exit Devices

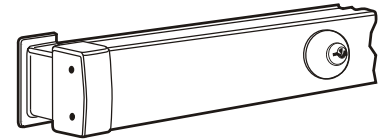

For management control of dogging. Any standard 15/16" to 1-1/8" long Mortise cylinder with MS® cam can be used in a pushbar prepared at factory with Cylinder Dogging kit. Cannot be used with Alarm or EL option.

Specify by adding "C" after exit device model number.

### ELECTRIC DOGGING

For all Adams Rite Exit Devices

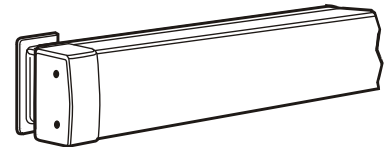

The "ED" option uses a holding magnet to keep the pushbar depressed (set manually) and the latch retracted. This gives a lower profile exit device, resulting in less damage and quieter operation. All "ED" devices include an internal microswitch that signals when the bar is held in the depressed position, ideal for automatic door operators. On fire-rated devices, it must be wired through the fire alarm system. All devices operate at 24VDC, drawing .6 amp, allowing them to operate with a simple transformer and rectifier.

Note: Not to be used as access control element. Specify "EL" with access control devices such as card reader or keypads.

Specify by adding "ED" after exit device model number (ex. 8611ED36).