

Heavy Duty Deadlatch

For Aluminum Stile Doors

4900 Series

ANSI/BHMA Type E8231 (Grade 1)

Both Flat and Radius Faceplates are supplied.



4902 Strike Furnished

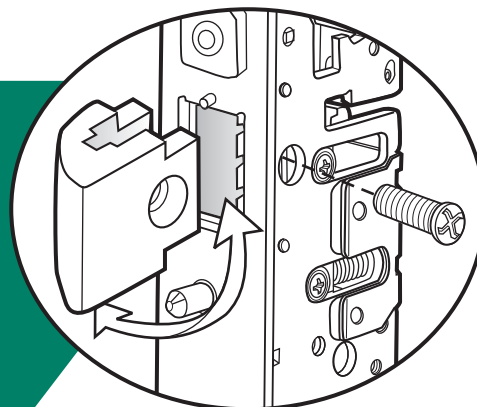
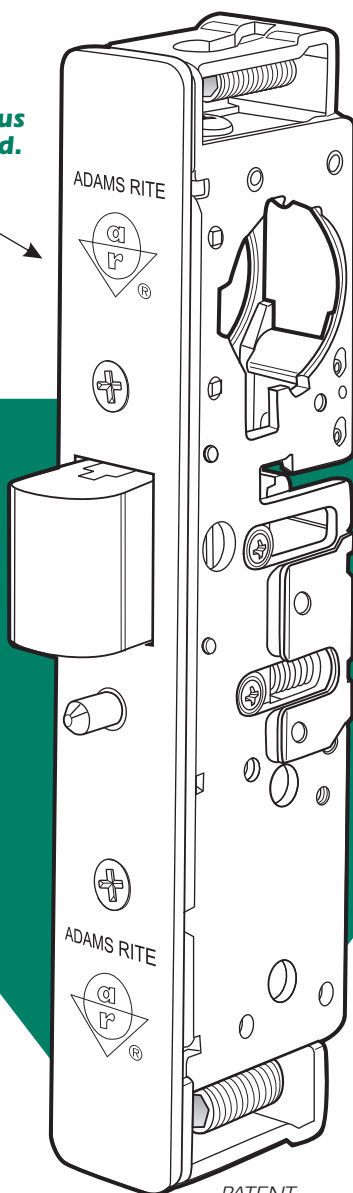

Field Reversible Latch Bolt

▼ Cylinder Backset

1-1/8" or 1-1/2" only.

▼ Case

Steel with corrosion-resistant plating. 7/8" x 5-13/16" x depth. (Depth varies by backset. See table on back page.) Screw-fastenend tube spacer brackets allow for cleaner removal when tab mounting.

▼ Function

Flexibility of traffic control and installation is offered by the 4900 Series Deadlatches. A reverse turn of the key while bolt is held retracted retains the bolt, to allow two-way traffic for applications which require free entrance at certain times and exit-only at other times. Interchangeable, without stile modification, with any MS1850A or MS1850S deadbolt of same backset and faceplate shape. Also retrofits to existing 4500/4700 Deadlatch preparations. 1-3/4" minimum door thickness required.

▼ Latch Bolt

5/8" x 1" x 5/8" throw. Solid brass. Handing is easily reversible using only a screwdriver.

▼ Auxiliary Latchpin

Stainless Steel. Deadlocks latch bolt to prevent "loiding" or case-knife entry.

▼ Faceplates

1" x 6-7/8". Both flat and radius faceplates are supplied. Flat faceplates can also be adjusted in the field for right or left beveled edge doors.

▼ Strikes

Standard strike furnished is 4902 for flat jamb where door closes flush or nearly flush. Specify 4901 for retrofit installations. Also available: radius strike for opposite stile in paired doors and long lip strikes for centerhung doors. (See page SW-27 and Electric Strike section.)

▼ Operation

Turn key or operate handle or paddle to retract spring-loaded latch bolt. To hold bolt retracted, push it in and secure by reverse turn of key (see back page). Uses any standard mortise cylinder with MS® cam (see page SW-33).



4900 Series Deadlatch

DIMENSIONS

INCHES
MILLIMETERS

Nominal, subject to tolerance extremes.

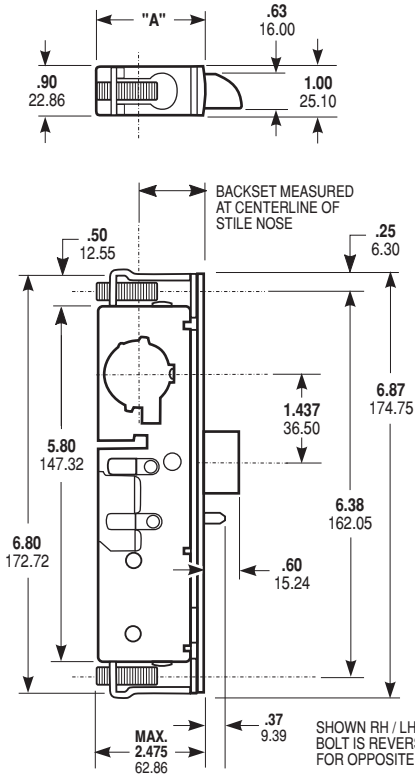

BACKSET	"A"
1-1/8" 28.6	1.76 44.7
1-1/2" 38.1	2.14 54.3

ARMORED FACEPLATE
1" x 6-7/8"

FLAT
P/N 24-0137-01-XXX

RADIUS
P/N 24-0137-02-XXX

RADIUS w/WEATHERSTRIP
ORDER SEPARATELY
P/N 24-0137-03-XXX

FLAT FACEPLATE CAN BE ADJUSTED FOR RIGHT OR LEFT BEVELED EDGE DOORS

Cylinder Cam

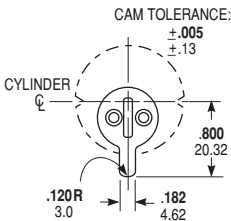

4900 Series Deadlatches are operable by any standard 1-5/32" diameter mortise cylinder with special MS® cam dimensioned as shown. Cylinders with MS® cams can be readily obtained from most cylinder manufacturers. See page SW-33 for cylinder make and trim ring information.

HOW TO ORDER

Specify quantity and the following information.
Order related hardware separately.

4900 Deadlatch
4911W Radius w/
Weatherseal

Backset
3 1-1/8"
4 1-1/2"

Handing*
5 LH or RHR
6 RH or LHR

*Handing can be reversed in field.

4900-35-201-628

Strike Size**
1 4.63"
(4901)
2 2.63"
(4902)

Strike Shape/Lip Length**
01 Flat/Standard Jamb
02 Radius/Standard Stile
17 Flat/Centerhung 4.0" Jamb
21 Flat/Centerhung 4.5" Jamb
XX Other Lip lengths

Faceplate Finish
628 Clear Anodized
313 Dark Bronze Anod.
335 Black Anodized

For other available finishes, contact factory.

**See page SW-27 4901/4902 for available strike options.

INSTALLATION

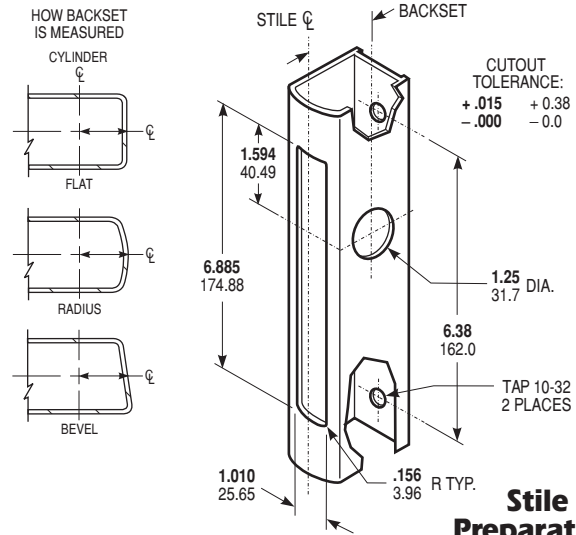

Stile Preparation

Identical to MS1850A or MS1850S Series
(See prep for 4591 Paddle)

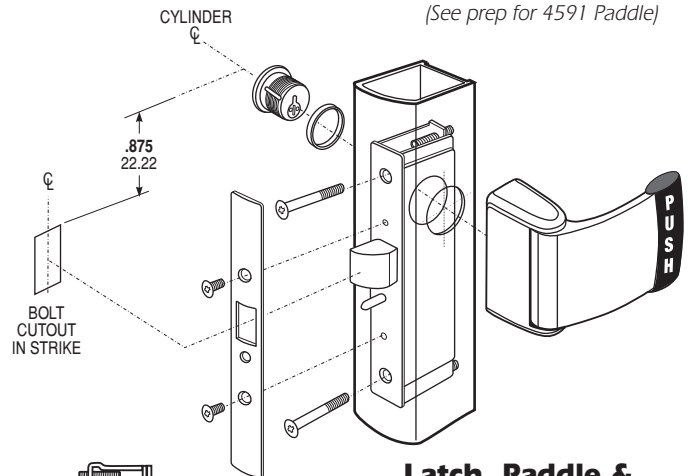

Latch, Paddle & Cylinder Installation

Bolt Holdback

A reverse turn of the key (while bolt is held fully retracted) retains the bolt, allowing the door to be free swinging.

OPTIONS

Backset, Strike and Finish must be specified when ordering. For handles, see page SW-28 & 29. For Paddles, see page SW-30 and SW-31. For outside entry Latch Pull, see page SW-32. Order Radius Faceplate with Weatherseal separately, P/N 24-0137-03-XXX (specify finish). See electric strike section for compatible access control products. See 4920AN Series for wood and steel door applications.

STANDARD PACKAGE

Individually boxed with Flat and Radius Faceplates, Strike and machine screws for mounting. Order cylinders, paddle, handle or latch pull separately. Shipping weight: 1-1/4 lbs.