

- NOTES:  
 1. FOR ADDITIONAL HANDLE INFORMATION SEE CATALOG PAGE #SW33.  
 2. FOR CYLINDER GUARD SEE CATALOG PAGE #SW13.  
 3. DIMENSIONS IN PARENTHESIS ARE IN MILLIMETERS.

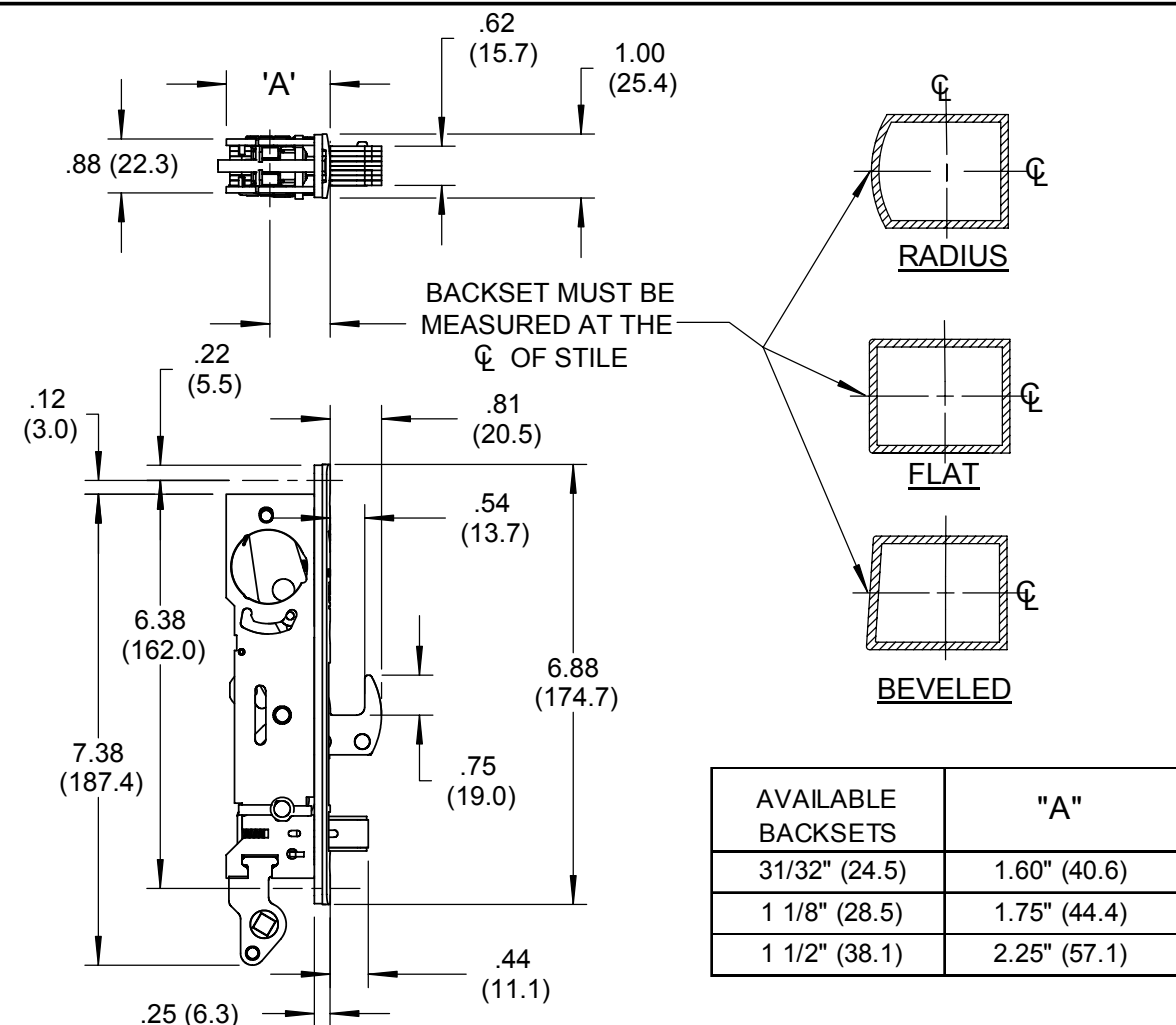

AVAILABLE BACKSETS	"A"
31/32" (24.5)	1.60" (40.6)
1 1/8" (28.5)	1.75" (44.4)
1 1/2" (38.1)	2.25" (57.1)

**STRIKE APPLICATIONS**

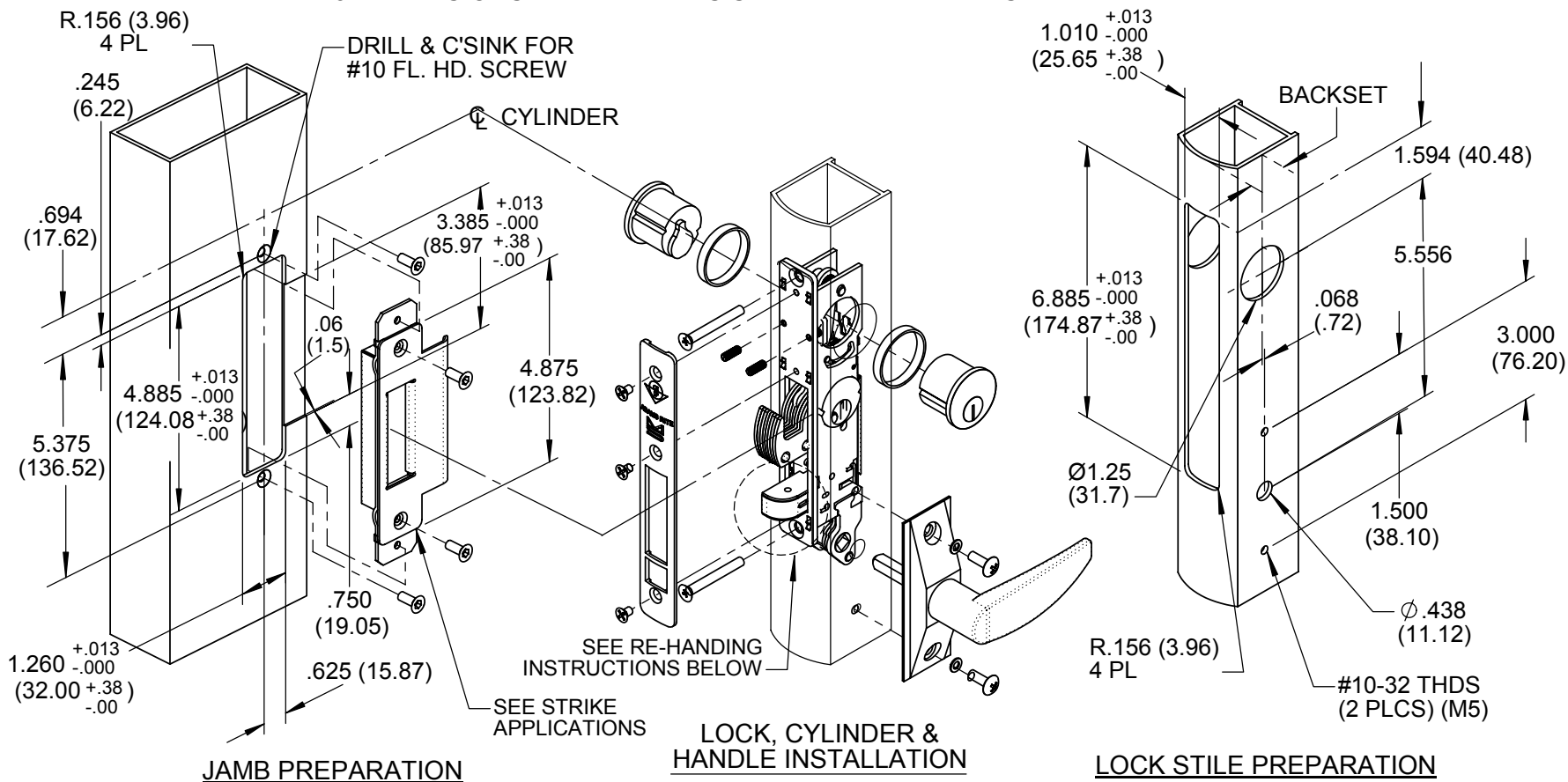
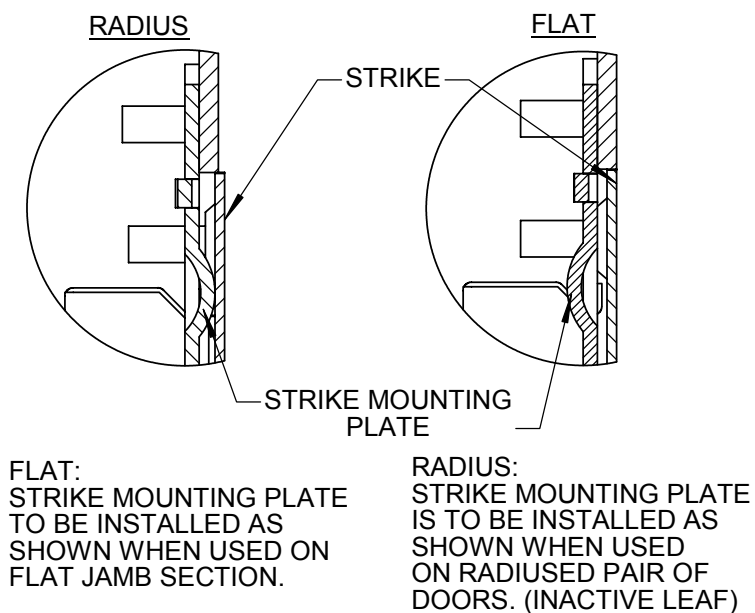

**RE-HANDING INSTRUCTIONS**

- USING ALLEN HEX KEY, LOOSEN THE SET SCREW AND REMOVE THE BOLT (FIG. 1)
- ROTATE 180°, INSTALL IT BACK AND RE-TIGHTEN THE SET SCREW (FIG. 2)

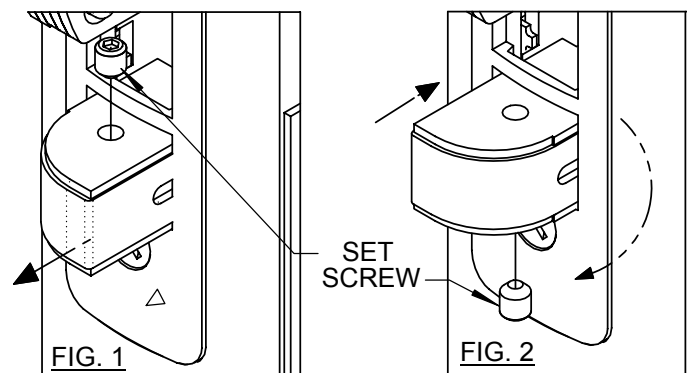

**MOUNTING METHODS**

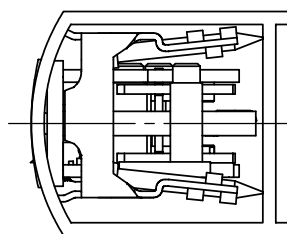

FOR MOUNTING INSTRUCTIONS SEE CATALOG PAGE #SW100

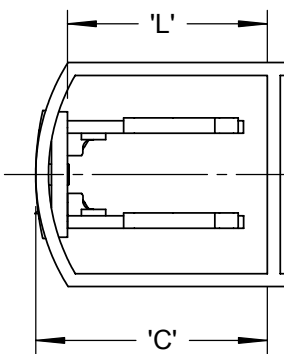

LOCK IS SECURED TO BACK WEB OF STILE BY MEANS OF #10 (M4) FLAT HEAD MACHINE SCREWS & TUBE SPACERS OF PROPER LENGTH TO POSITION LOCK. FOR TUBE SPACER LENGTH (L) USE THE FOLLOWING FORMULA:

$$L = C - .25 (6.35)$$

SCREWS FURNISHED WILL BE APPROX. 1/4" LONGER THAN THE SPACER.

**AVAILABLE FACEPLATES**

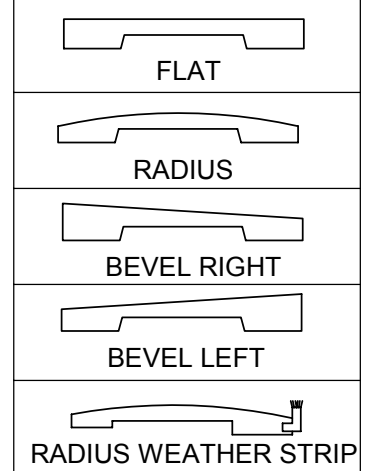

\* MINIMUM SINGLE ACTION GAP 1/8" (3.1) WHEN USING WEATHER SEAL FACEPLATE