

MS® Deadbolt

For Aluminum Stile Doors - 1" x 6-7/8" Faceplate

MS1950-050 Series

ANSI/BHMA Type E5281/E5291 (Grade 1)

NEW!

ALL STAINLESS STEEL
CONSTRUCTION

▼ **Cylinder Backset**
31/32", 1-1/8" or 1-1/2" only.

▼ **Case**
Fully stainless steel case and internal components. 1" x 6" x depth. (Depth varies by backset. See table on back page.)

▼ **Function**
The MS® Hookbolt deadlock answers the security need of sliding glass doors in commercial, industrial and institutional buildings. The mechanism is identical to the widely used Maximum Security swinging door lock, except that the massive laminated bolt is provided in a hook shape to resist the parting motion of sliding door and jamb. The overcenter MS locking action assures that forced entry attempts to pry the door in any direction, up, down or sideways, will be defeated.

▼ **Bolt**
5/8" x 1-3/8" with 13/16" throw. Eight-ply laminated stainless steel with Alumina Ceramic core defeats any hacksaw attack (including so-called super hacksaws) while hook shape repels prybar attempts to "spread" door from its jamb or lift it off its track.

▼ **Strike**
See back page for dimensions of strike slot which can be cut in metal jamb. Trim plate, box strike and armored strike are also available. (See page SW-16).

▼ **Operation**
360° turn of key or thumbturn throws or retracts the counterbalanced bolt. Key can be removed only when bolt is in a positively locked or unlocked position. Lock accepts any standard 1-5/32" diameter mortise cylinder or thumbturn from either or both sides. Cylinder must have MS dimensioned cam. (See page SW-35).



MS 1950-050 Deadbolt

DIMENSIONS

INCHES
MILLIMETERS
Nominal, subject to tolerance extremes.

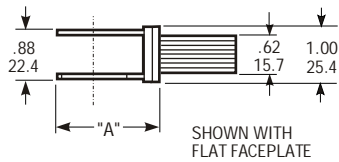

BACKSET	"A"
31/32"	1.63
24.6	41.4
1-1/8"	1.78
28.6	45.2
1-1/2"	2.25
38.1	57.1

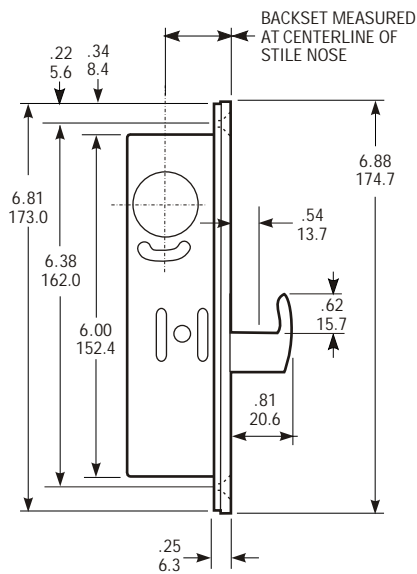

ARMORED FACEPLATE 1" x 6-7/8"	
FLAT	MS1950-050
RADIUS	MS1951-050
RADIUS w/WEATHERSTRIP	MS1951W-050
LH BEVEL	MS1952-055
RH BEVEL	MS1952-056

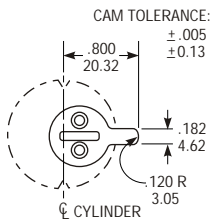

Cylinder Cam

MS1950-050 Series locks are operable by any standard 1-5/32" diameter mortise cylinder with special MS® cam dimensioned as shown. Cylinders with MS cams can be readily obtained from most cylinder manufacturers. See page SW-35 for cylinder make and trim ring information.

INSTALLATION

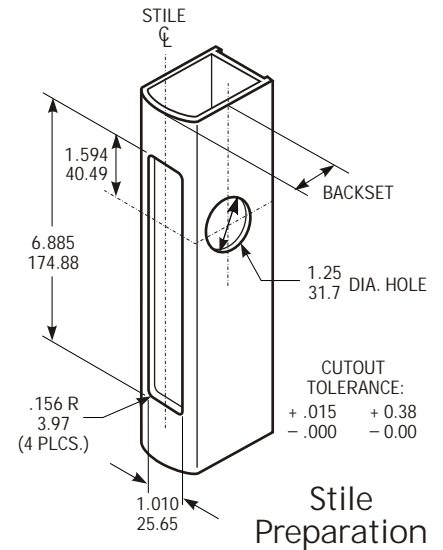
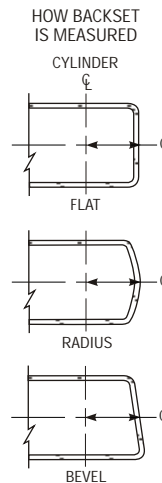

Stile Preparation

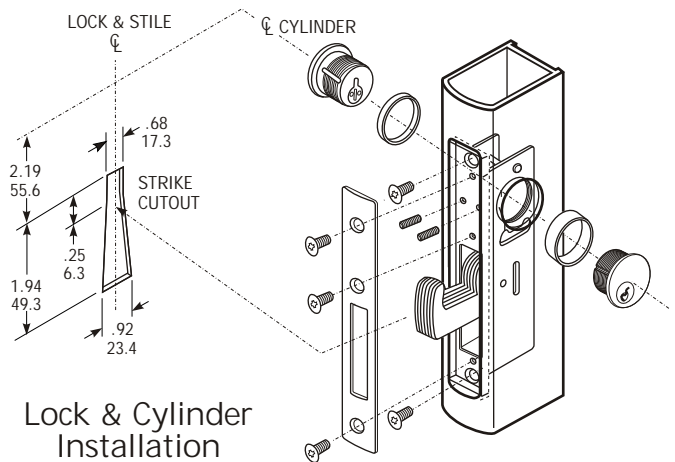

Lock & Cylinder Installation

HOW TO ORDER

Specify quantity and the following information.
Order related hardware separately.

Faceplate Shape	Backset	Handing
1950 Flat	2 31/32"	55 LH or RHR
1951 Radius	3 1-1/8"	56 RH or LHR
1951W Radius w/wstrip	4 1-1/2"	50 Non-Handed*
1952 Bevel		

MS1950 - 250 - 628

Finish
628 Clear Anodized
313 Dark Bronze Anod.
335 Black Anodized

*Any flat or radius face.

OPTIONS

Cylinder backset and faceplate finish and shape (radiused, flat or bevel cross-section to match door nose) must be specified.

STANDARD PACKAGE

Individually boxed with machine screws for mounting. Cylinders and/or thumbturn available at extra cost. Shipping weight: 1-1/2 lbs.