

## Strikes

### 4800 Series, MS4804

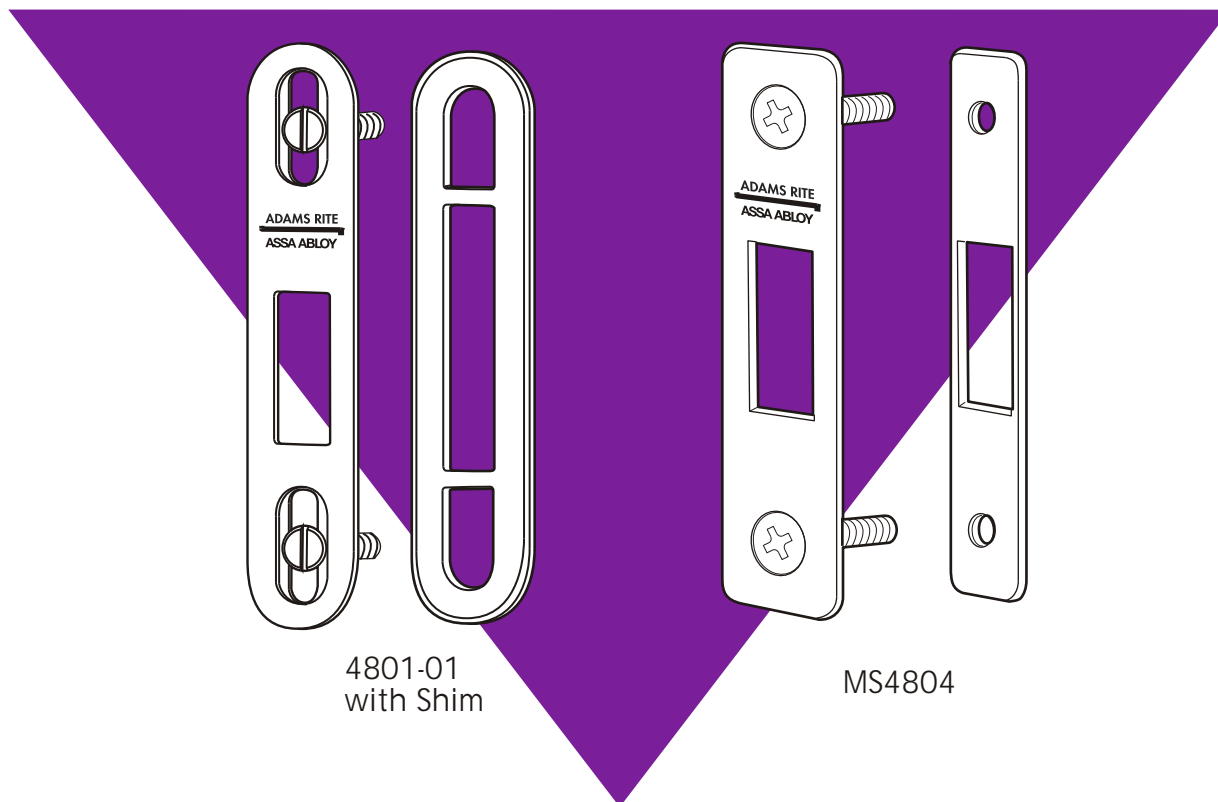

4801-01  
with Shim

MS4804

#### 4800 Series

##### ▼ Function

With vertical adjustment to accommodate door/jamb misalignment and a shim system for horizontal positioning to match various jamb bumper designs, 4800 Series strikes can be fit to nearly any sliding door using a mortised MS1847 Series lock or latch. 4801 strikes are furnished with sheet metal screws for metal jamb installation. 4802 strikes are furnished with machine screws and tee nuts which are installed on the back side of jamb to provide the strongest possible anchorage in wood.

##### ▼ Material

Steel, heat treated. Shims are ABS plastic. Zinc (603) finish. For other finishes contact factory.

#### MS 4804

##### ▼ Function

Provides a strike equal to the strength of the stainless steel bolt of the MS1847 Deadlock: tested to 1,000 lbs. of force. This strength exceeds by far the standards of the Architectural Aluminum Manufacturers Association as well as the strictest current municipal security ordinance.

##### ▼ Faceplate

1/16" x 3/4" x 3-3/8". Steel, plated for corrosion resistance. MS4804-10 available in Stainless Steel.

##### ▼ Reinforcing Plate

1/16" x 1/2" x 3-3/8". Steel, plated for corrosion resistance. Tapped for furnished #10-32 flathead screws.



# 4800 Series, MS4804 Strikes

## DIMENSIONS

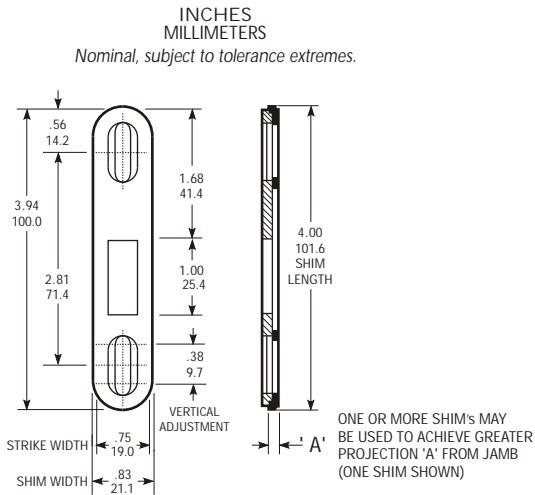

## INSTALLATION

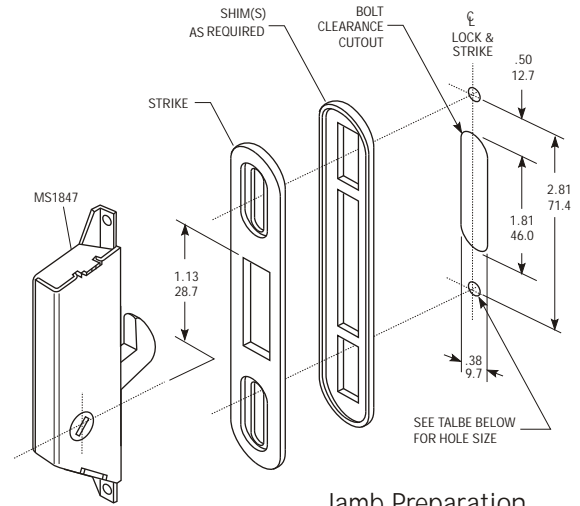

Jamb Preparation

### 4800 Series

PART NO.	SHIMS	DIMENSION 'A'	APPLICATION
4801	None	0"	METAL JAMBS (Furnished with two #8 x 1 sheet metal screws.)
4801-01	1	3/32" 2.4	
4801-02	2	3/16" 4.8	
4801-03	3	9/32" 7.1	

PART NO.	SHIMS	DIMENSION 'A'	APPLICATION
4802	None	0"	WOOD JAMBS (Furnished with two #8-32 x 7/8 machine screws and two tee nuts.)
4802-01	1	3/32" 2.4	
4802-02	2	3/16" 4.8	
4802-03	3	9/32" 7.1	

	HOLE SIZE
METAL JAMB APPLICATION 4801 SERIES	.120 (No. 31 DRILL) 3.0
WOOD JAMB APPLICATION 4802 SERIES	.213 (No. 3 DRILL) 5.4

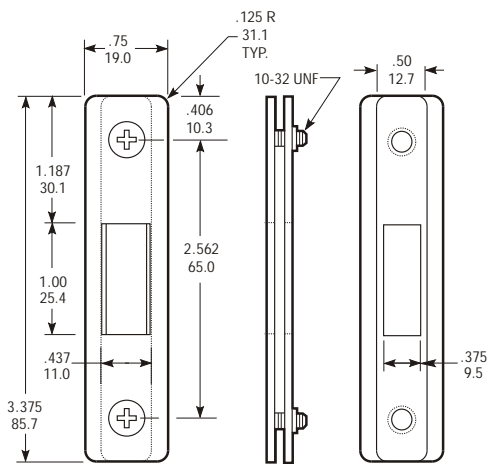

MS4804

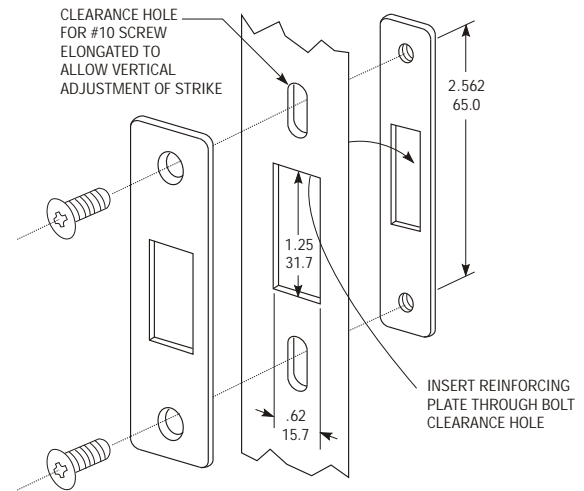

## HOW TO ORDER

Specify quantity and Part Number.  
 Add dash number for 4800 Series (See table above).  
 Order related hardware separately.

## STANDARD PACKAGE

All strikes are individually packaged in envelope with screws and shim if required.