

Standard Duty Deadlatch

For Aluminum Stile Doors - 1-1/4" x 7-3/8" Faceplate

4530 Series

ANSI/BHMA Type E8231 (Grade 1)

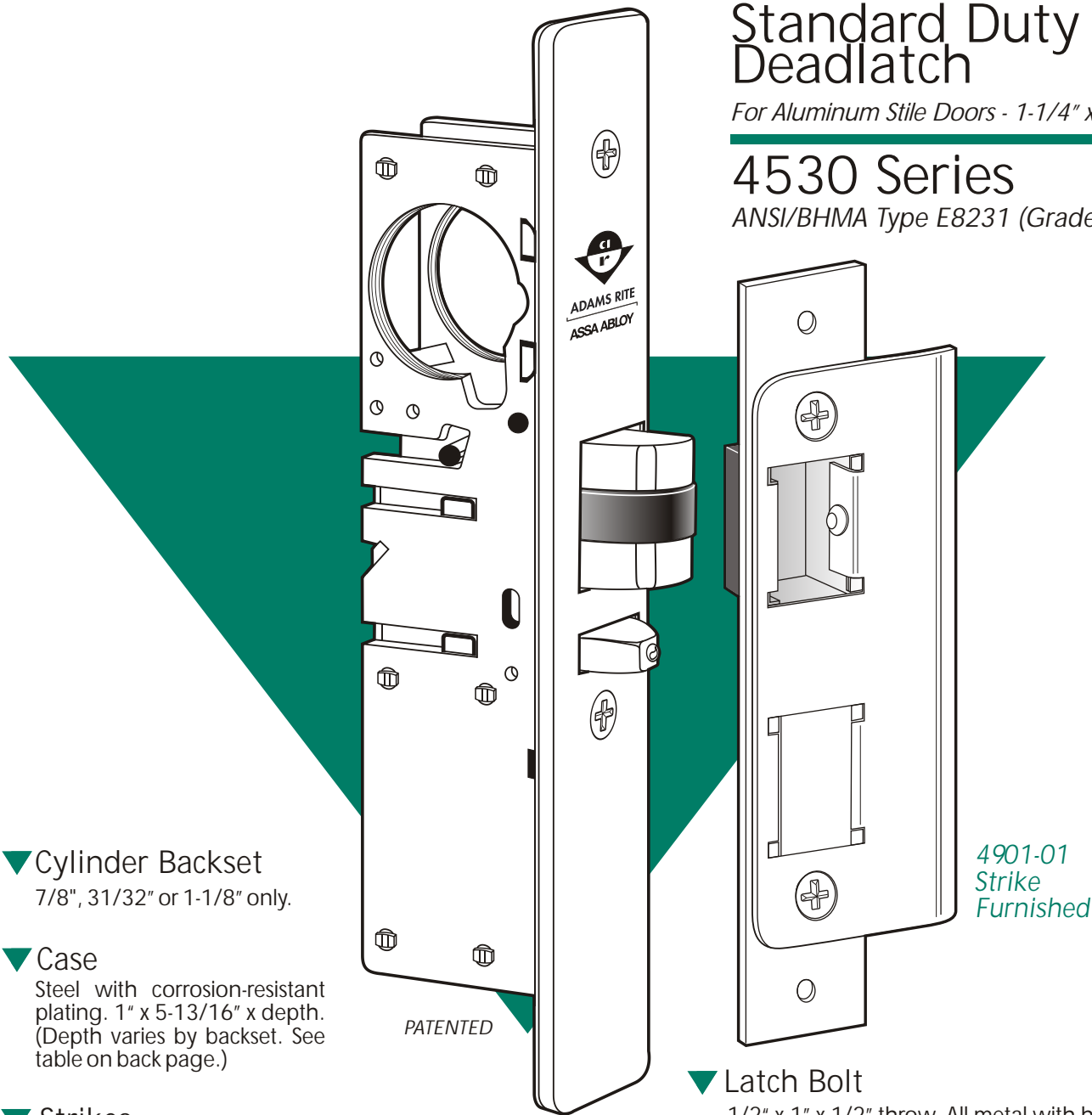

▼ **Cylinder Backset**
7/8", 31/32" or 1-1/8" only.

▼ **Case**
Steel with corrosion-resistant plating. 1" x 5-13/16" x depth. (Depth varies by backset. See table on back page.)

▼ **Strikes**
Standard strike furnished is 4901-01 for flat jamb. For dimensions of this as well as radiused and/or short strikes, see page SW-28. (See also Electric Strike section.)

▼ **Function**
4530 Series Deadlatches are designed to fit, without alteration, the stile cutout for older MS1850* Series Deadbolts of same backset. (They do not, however, provide the maximum security level of the MS® Deadbolt and should not be considered an equivalent replacement.) Also replaces, without alteration, older 4250 Series Deadlatches.
*Not MS1850A or S

▼ **Latch Bolt**
1/2" x 1" x 1/2" throw. All metal with hardened steel internal pins. Handing is easily reversible without special tools.

▼ **Auxiliary Bolt**
All metal. Deadlocks latch bolt to prevent "loiding" or case-knife entry.

▼ **Operation**
Turn key or operate handle to retract spring-loaded latch bolt. To hold bolt retracted, push it in and secure by reverse turn of key (see back page). Uses standard mortise cylinder with MS cam (see page SW-35).



4530 Series Standard Duty Deadlatch

DIMENSIONS

INCHES
MILLIMETERS
Nominal, subject to tolerance extremes.

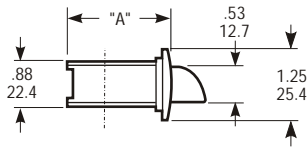

BACKSET	"A"
7/8"	1.51
22.2	38.3
31/32"	1.60
24.6	40.6
1-1/8"	1.76
28.3	44.7

ARMORED FACEPLATE 1-1/4" x 7-13/32"	
FLAT	4530
RADIUS	4531
RH BEVEL	4532(RH)
LH BEVEL	4532(LH)

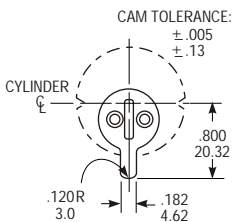
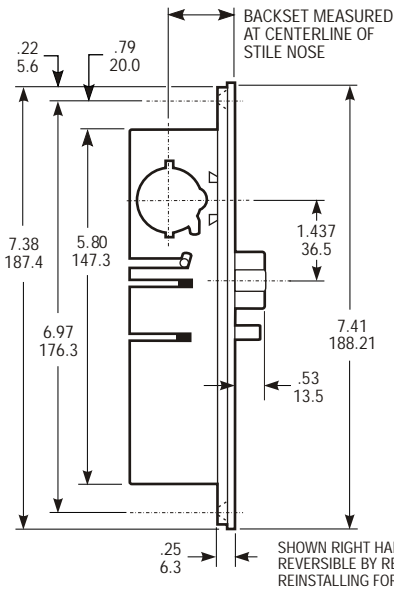

Cylinder Cam

4530 Series Deadlatches are operable by any standard 1-5/32" diameter mortise cylinder with special MS® cam dimensioned as shown. Cylinders with MS cams can be readily obtained from most cylinder manufacturers. See page SW-35 for cylinder make and trim ring information.

HOW TO ORDER

Specify quantity and the following information.
Order related hardware separately.

Faceplate Shape	
0	Flat
1	Radius
2	Bevel

Backset	
1	7/8"
2	31/32"
3	1-1/8"

Handing	
5	LH or RHR
6	RH or LHR

4531 - 36 - 101 - 628

Strike Size	
1	4.63" (4901)*
2	2.63" (4902)*

Strike Shape/Lip Length	
01	Flat/Standard Jamb
02	Radius/Standard Stile
17	Flat/Centerhung 4.0" Jamb
21	Flat/Centerhung 4.5" Jamb
XX	Other Lip lengths

Faceplate Finish	
628	Clear Anodized
313	Dark Bronze Anod.
335	Black Anodized

For other available finishes, contact factory.

*See pg SW-28

INSTALLATION

HOW BACKSET IS MEASURED

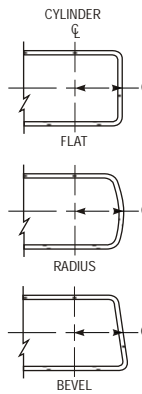

To replace old MS1850 lock or 4250 latch of same backset:
NO PREPARATION REQUIRED

To replace 4070 lock, old 4050 latch, 970 lock or 1450 latch of same backset:

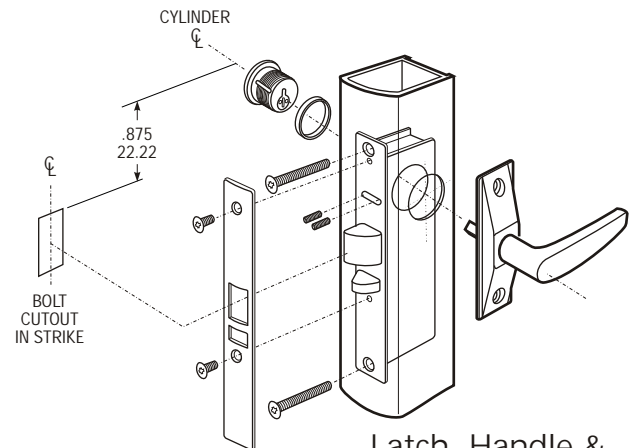
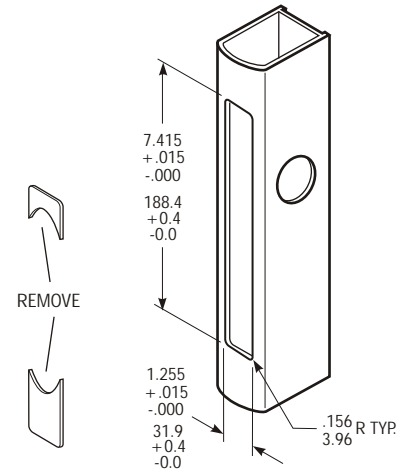

Latch, Handle & Cylinder Installation

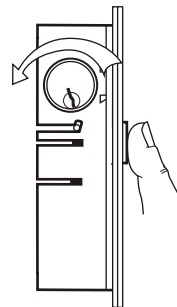

Bolt Holdback

A reverse turn of the key (while bolt is held fully retracted) retains the bolt, allowing the door to be free swinging.

OPTIONS

Backset, Faceplate Shape, Finish, Strike and Handing must be specified when ordering. For Handles, see page SW-29 & 30. For Paddles, see page SW-31 & SW-32.

STANDARD PACKAGE

Individually boxed with strike and machine screws for mounting. Cylinders, paddle or handle available at extra cost. Shipping weight: 1-1/4 lbs.