

Two-Point Deadbolt

For Roll-Up Doors/Grills

1875

ANSI/BHMA Type E86182 (Grade 2)

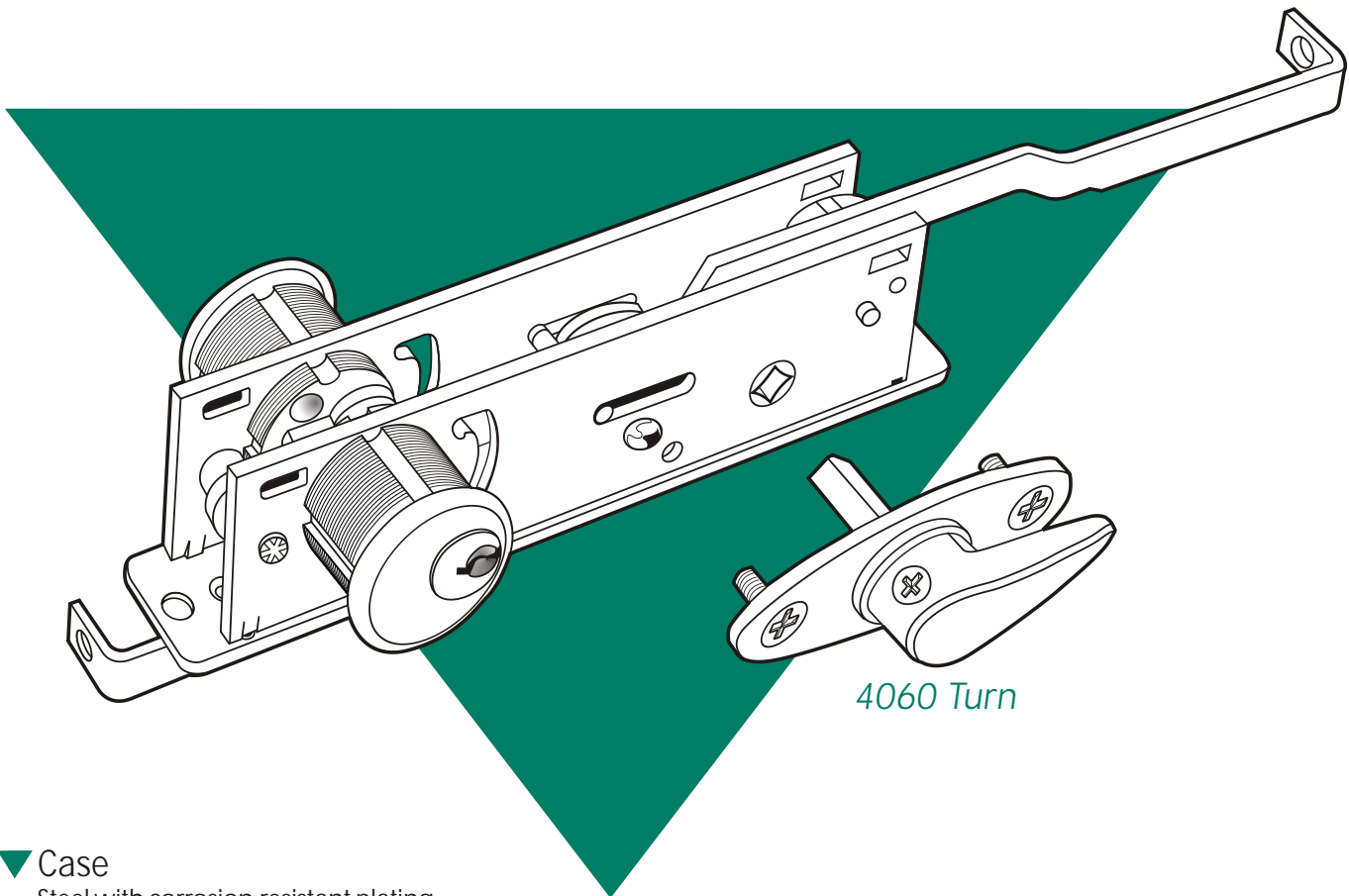

4060 Turn

▼ Case

Steel with corrosion-resistant plating.
1" x 6" x 2"-5/8".

▼ Bolt Arms

1-1/32" throw. Threaded for 1/4"-20 rods. Because of design variations in this type of door, no standard bolt can be offered to fit all makes of doors. Contact Adams Rite factory concerning bolts, rods, bolt guides and strikes to fit individual door designs.

▼ Function

For overhead "garage" doors, roll-up security screens or similar doors. Provides turn operation of two bolts from either or both sides. Accepts standard mortise cylinders for key control of bolts to secure them in either projected or retracted position.

▼ Cylinder Backset

Bolt arms require inside stile clearance of 1-11/16" on one side of cylinder center, 1" on the other.

▼ 4060 Turn

Zinc alloy escutcheon and handle. Finish is US26D. Steel spindle is also available to accommodate various door thicknesses.

▼ Operation

90° rotation of turn throws or retracts bolts. 360° turn of key deadlocks mechanism, preventing operation of the turn in either locked or unlocked position.



1875 Two-Point Deadbolt

for Roll-Up Doors/Grills

DIMENSIONS

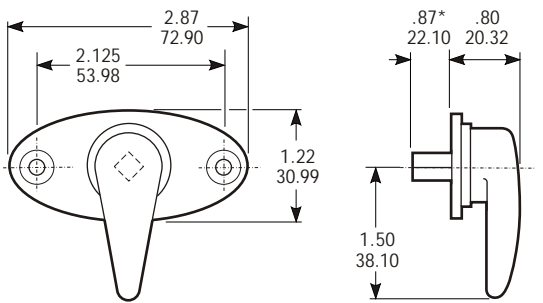
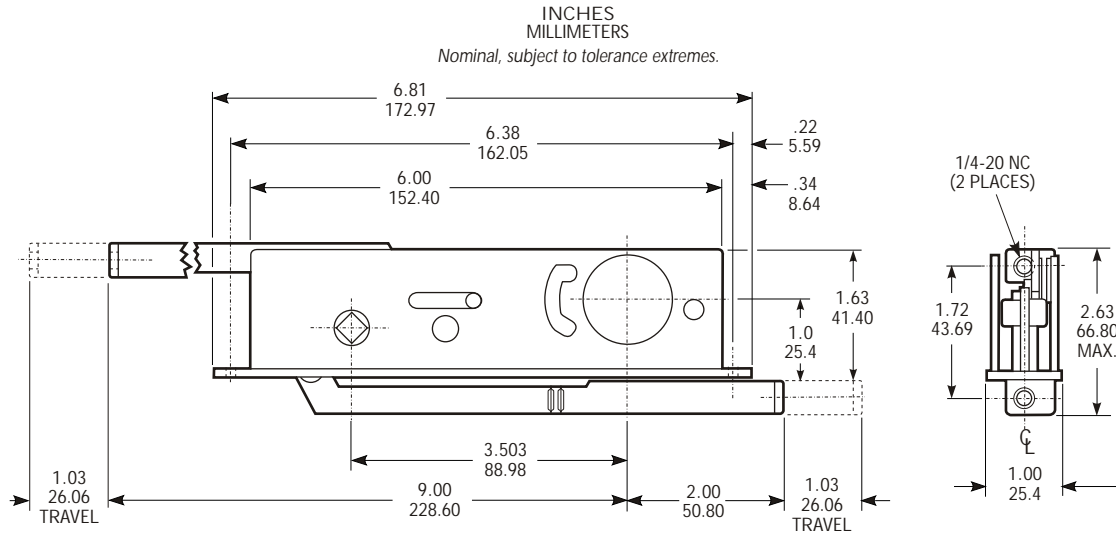

4060 Turn

*FOR 1-3/4" THICK DOOR

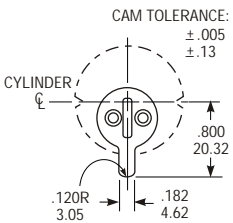

Cylinder Cam

1875 deadbolts are operable by any standard 1-5/32" diameter mortise cylinder with special MS® cam dimensioned as shown. Cylinders with MS cams can be readily obtained from most cylinder manufacturers. See page SW-35 for cylinder make and trim ring information.

INSTALLATION

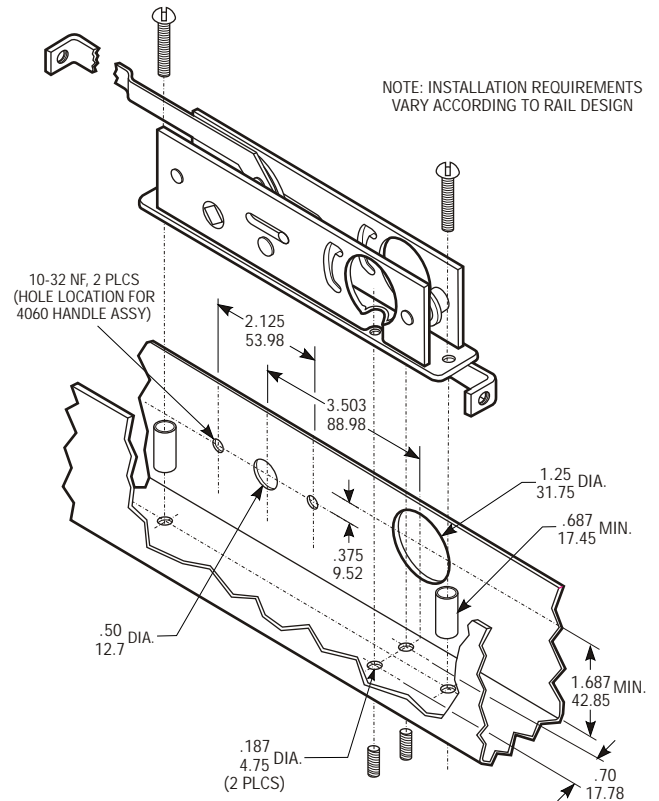

HOW TO ORDER

Specify quantity and part number.
Order related hardware separately.

1875 - IB

Specify 4060 Turn separately, including quantity and door thickness.

4060 - 05 -05 1-1/2" Door Thickness
-06 1-3/4" Door Thickness
-07 2" Door Thickness

Contact factory regarding mounting spacers, bolts, guides and strikes for a particular door design.

OPTIONS

4060 Turn shown is available with choice of spindle lengths. Bolts, connecting rods, bolt guides and strikes are available on special order. Cylinders also available separately.

STANDARD PACKAGE

Shipping weight: 1-1/2 lbs.