

# Installation Instructions

## VS110-75 Series Electric Strike 5/8" - 3/4" Latchbolts



Security Products by HES  
22630 N 17th Ave. Phoenix, AZ 85027  
800.626.7590 www.hesinnovations.com/vista

1. Make sure electric strike is in correct mode of operation, Fail Secure or Fail Safe (see Diagram 1).
2. Prepare door jamb per appropriate template detail (see back).
3. Install mouting tabs using #10-32 screws (when applicable). Do not tighten. Install sticky shims as needed between tabs and frame until faceplate is flush with the frame.
4. Check power source to ensure there is correct voltage at the door to accommodate the electric strike (see Caution below).
5. Connect wires coming from the low voltage power source to the electric strike wires using dolphin connectors (see Diagram 2 for electrical specifications).
6. If AC power is provided, use an HES 2001-1 Bridge Rectifier when using the electric strike in continuous "silent" duty operation (see Diagram 3).
7. **NOTE:** It is important to allow enough space behind the electric strike in the jamb cutout to avoid pinching the wires during installation.
8. Install electric strike to jamb cutout using #12-24 machine screws or wood screws provided.
9. Secure #10-32 screws holding mounting tabs (when applicable).

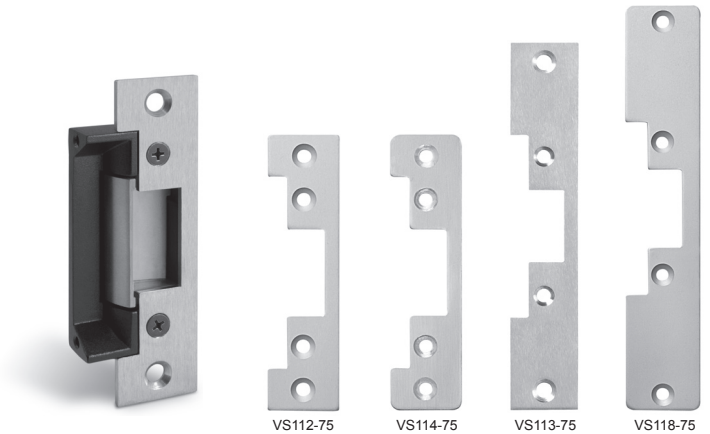

**DIAGRAM 2 ELECTRICAL SPECIFICATIONS**

ELECTRICAL RATINGS FOR SOLENOID	CONTINUOUS DUTY		INTERMITTENT DUTY*	
	12VDC	24VDC	12VAC	24VAC
Resistance in Ohms	49	128	49	128
Amps	0.243	0.187	0.243	0.187

MINIMUM WIRE GAUGE REQUIREMENTS	SOLENOID VOLTAGE	
	12 VDC	24VDC
200 feet or less	18 gauge	20 gauge
200 - 300 feet	16 gauge	18 gauge
300 - 400 feet	14 gauge	16 gauge

Solenoids are rated at +/- 10% indicated value.  
\*20% max duty cycle (1 min. max on time)

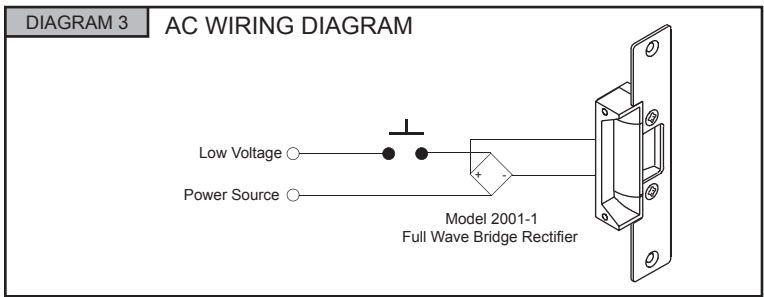
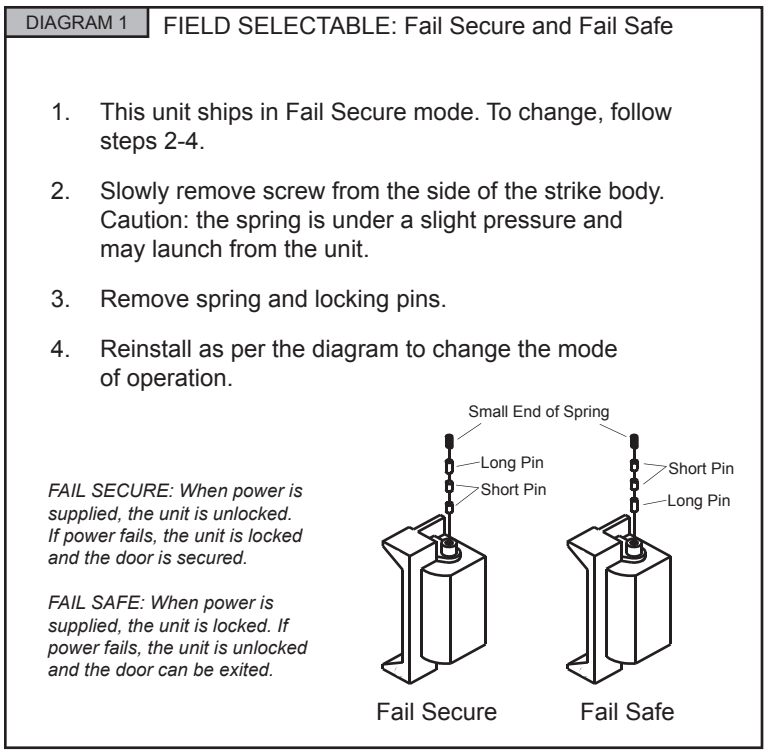

**CAUTION!** Before connecting any device at the installation site, verify input voltage using a multimeter. Many power supplies and low voltage transformers operate at higher levels than listed. Any input voltage exceeding 10% of the solenoid rating may cause severe damage to the unit and will void the warranty.

Strikes requiring 12VDC/VAC have RED wires; 24VDC/VAC have BLUE wires.

Call 1-800-626-7590  
For Technical Assistance

**VS112-75 Series Electric Strike**

1-1/4" x 4-7/8" Square Corner Faceplate  
ANSI Metal Jamb Installation

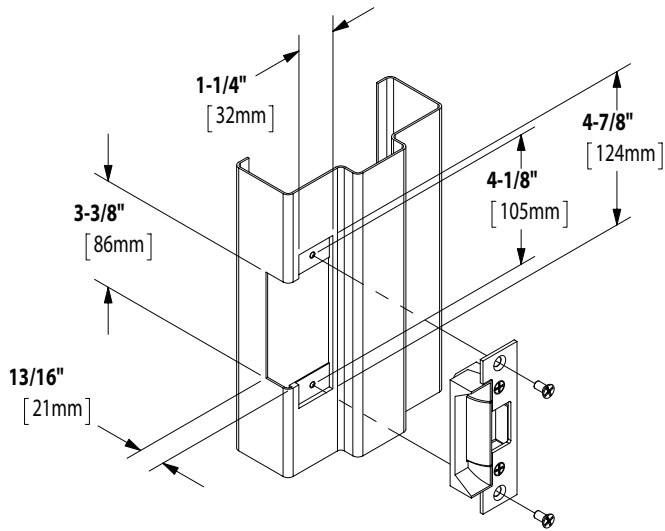

**VS114-75 Series Electric Strike**

1-1/4" x 4-7/8" Round Corner Faceplate  
Aluminum Jamb Installation

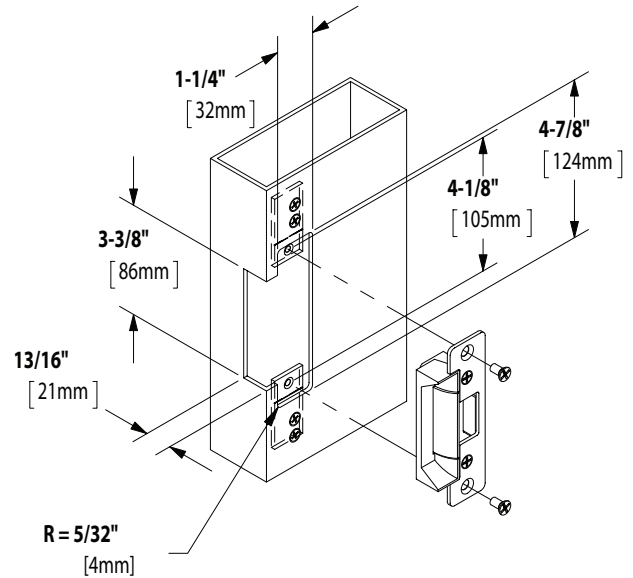

**VS113-75 Series Electric Strike**

1-1/4" x 6-7/8" Square Corner Faceplate  
Aluminum and Wood Jamb Installation

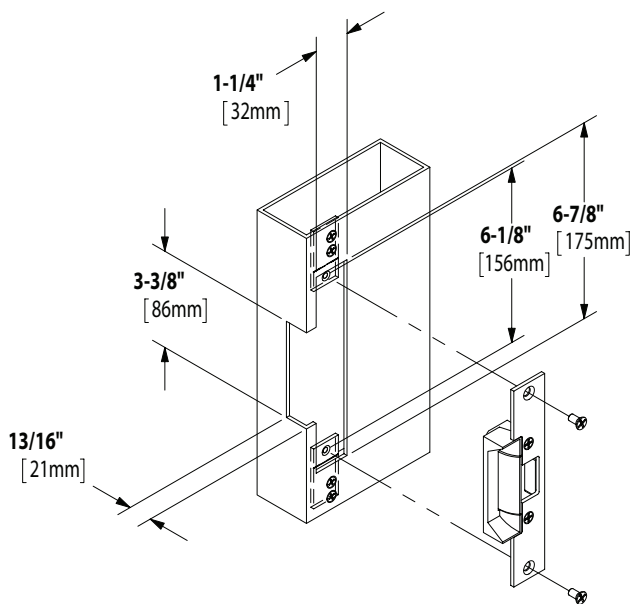

**VS118-75 Series Electric Strike**

1-3/8" x 7-15/16" Round Corner Faceplate  
Aluminum and Wood Jamb Installation

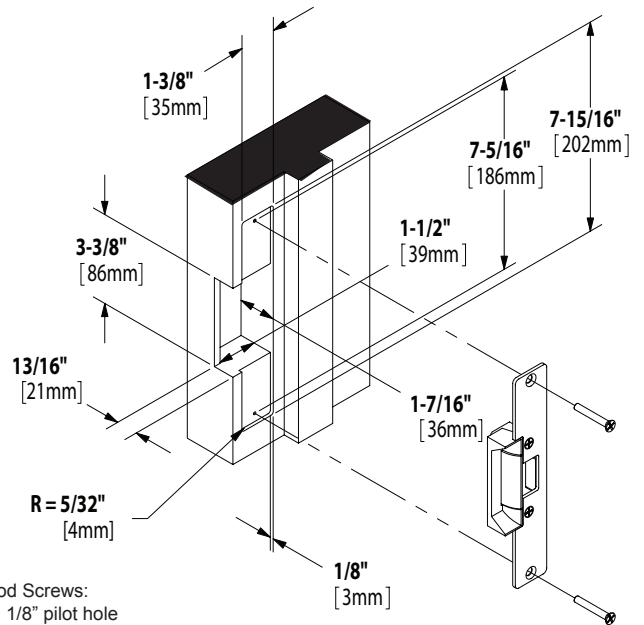

Wood Screws:  
Drill 1/8" pilot hole  
1" deep times 2