



ROFU[®] ELECTRIC STRIKE MODEL 1701

1701- SERIES, FACEPLATE SIZE 1¼" x 5⅞"

MODEL 1701 — Fail - Secure (Non Fail - Safe)

Electric strikes for use with mortise and cylindrical locksets.

For Commercial and Residential, New and Retrofit Uses

Standard Features



1701
Non-Handed

- Steel Faceplate
- Frame Type - Wood
- Corrosion - Resistant case and moving parts.
- Tamper Strength Test - 1000 lbs (454kg)
- Cycle Test 500,000 cycles
- Keeper Depth - **1/2"** Maximum Latch Projection possible with 1/8" Door/Frame Clearance - **5/8"**
- Strike Depth 1.29" Overall
- Reversible - Non Handed
- Adjustable Keeper (FAFIX)
- Limited Warranty - **36 Months**

Available in the following Voltages and Finishes:

Specify Finish	xUS26D or xUS4
Voltage, Fail Secure	x01=8-16VAC/3-6VDC (Intermittent Duty)
	x04=12VAC/12VDC (Intermittent Duty)
	x07=24VAC/24VDC (Intermittent Duty)
	x05=12VDC(Continuous Duty)
	x08=24VDC (Continuous Duty)
	x14=48VAC/48VDC (Intermittent Duty)



LINE ART FOR 1701

WOOD JAMB PREPARATION

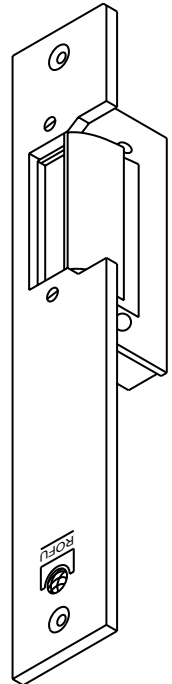
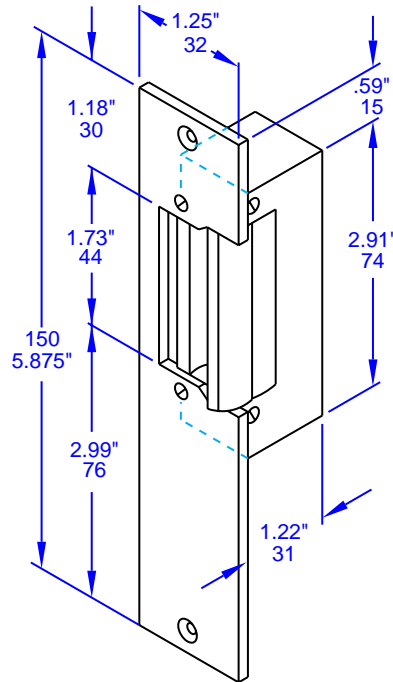
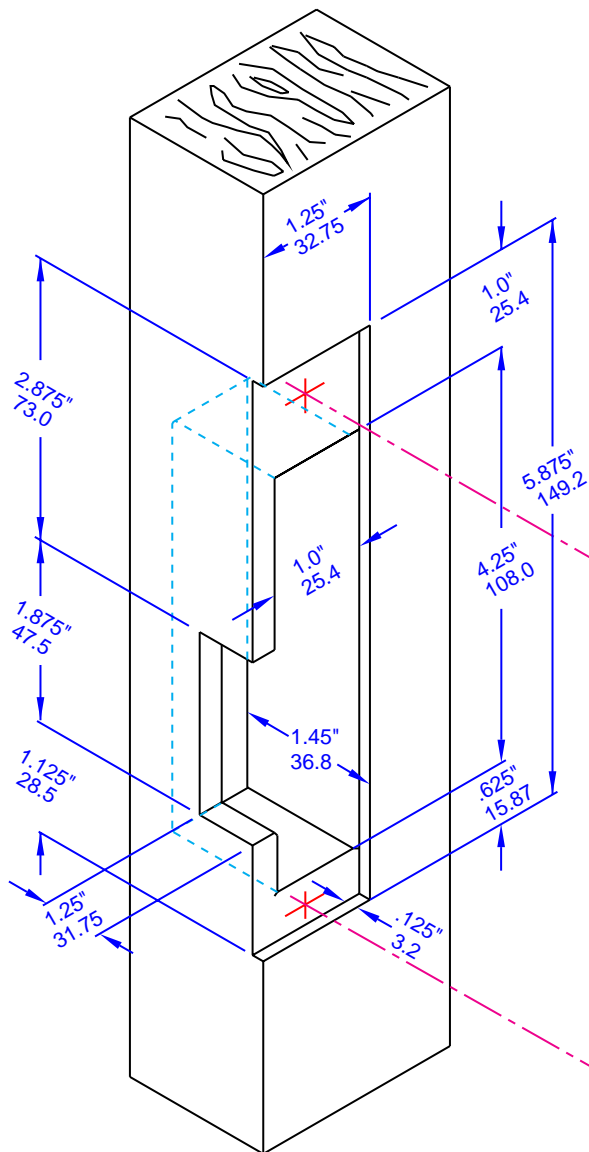

INSTALLATION

