



**SECURITY DOOR CONTROLS**  
 3580 Willow Lane  
 Westlake Village, CA 91361  
 (805) 494-0622 FAX (805) 494-8861  
 www.sdcsecurity.com E-mail: service@sdsecurity.com

**REGULATED POWER SUPPLY  
 INSTALLATION INSTRUCTIONS**

**MODEL 631RF/631RFA**

**Model 631RF/631RFA**

**COMPONENT LOCATIONS**

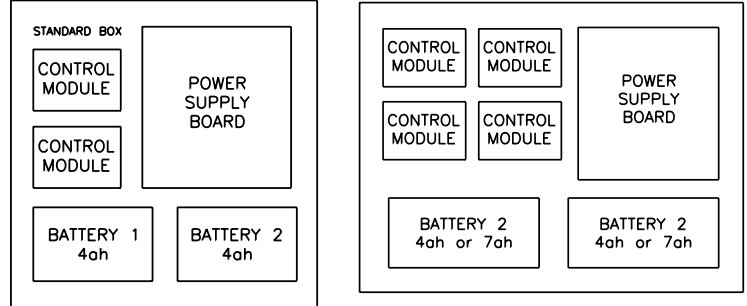
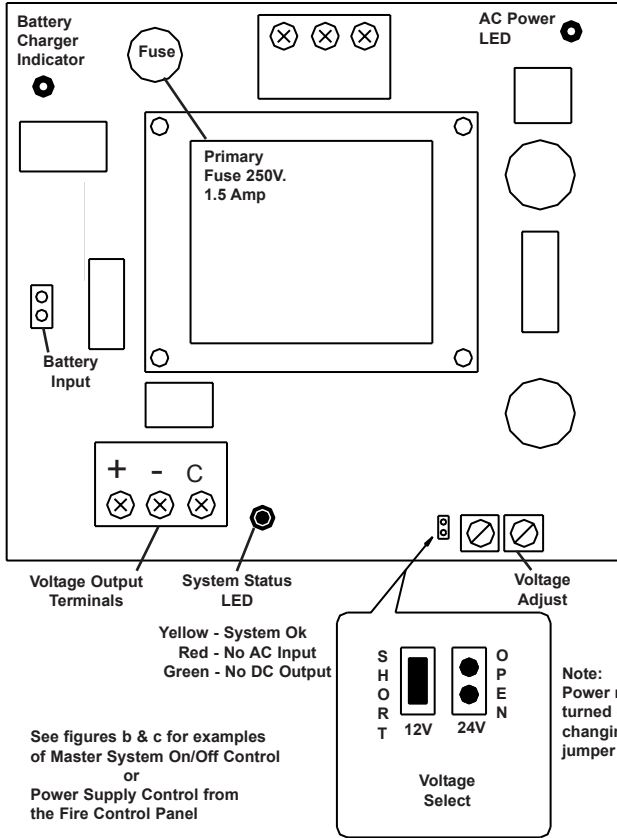

**MAIN SYSTEM ON-OFF  
 OR  
 FIRE PANEL CONNECTION**

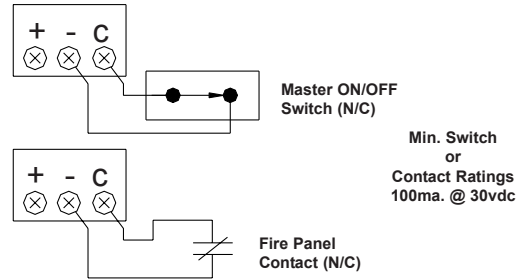

**POWER SUPPLY SPECIFICATIONS**

Input Voltage: 115/230 vac @ 60hz  
 Input Current: 0.8 amps Max.

Output Voltage: 12/24vdc. (Regulated)  
 Output Current: 1.5 amps  
 Ripple Voltage: 0.05 Volts Max

Battery Charger Max Current: 0.25 amps  
 Maximum recommended battery size: 7ah  
 (Replace batteries every 3 years)

To determine standby battery capacity refer to Battery Discharge table (INST-BDT)

Suitable Uses:  
 Electric Lock Power Supply  
 Access Control Power Supply  
 Burglar Alarm System Power Supply

**NOT INTENDED TO POWER A LOCAL BURGLAR ALARM INDICATING DEVICE**

**TEST UNIT YEARLY**

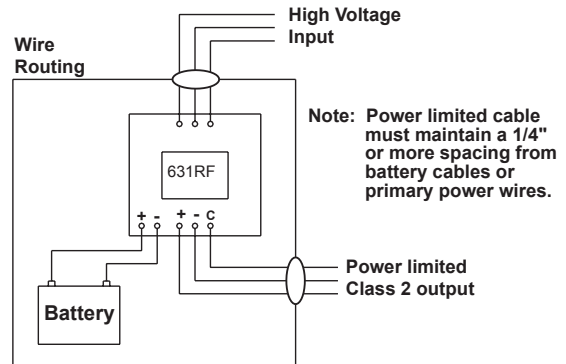
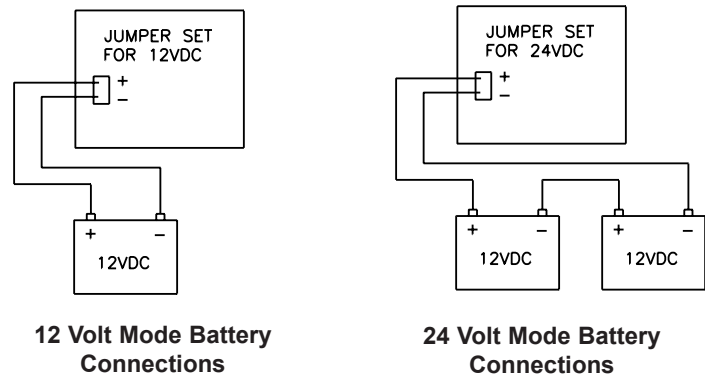



**SECURITY DOOR CONTROLS**  
 3580 Willow Lane  
 Westlake Village, CA 91361  
 (805) 494-0622 FAX (805) 494-8861  
 www.sdcsecurity.com E-mail: service@sdsecurity.com

**REGULATED POWER SUPPLY  
 INSTALLATION INSTRUCTIONS**

**MODEL 631RF-CUL/631RFA-CUL**

**Model 631RF-CUL/631RFA-CUL**

**COMPONENT LOCATIONS**

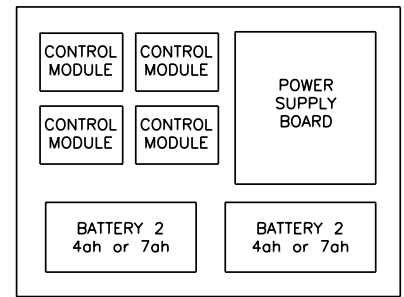
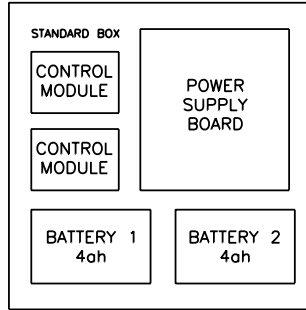
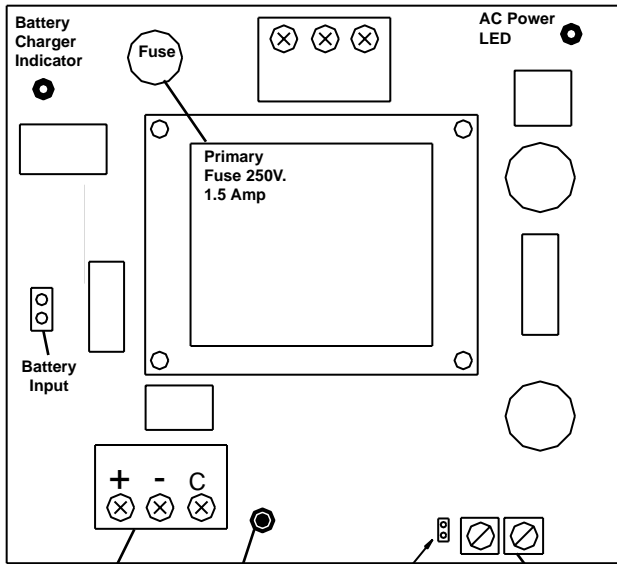

STANDARD BOX

'A' OPTION BOX

**COVER**

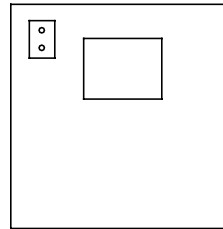

BATTERY MONITOR LEADS  
 GRN = AC  
 RED = BATTERIES  
 ORG = LO/NO BATTERY

**MAIN SYSTEM ON-OFF**

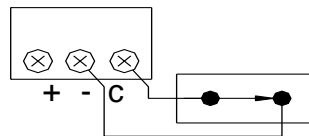

Min. Switch or Contact Ratings 100ma. @ 30vdc  
 Master ON/OFF Switch (N/C)

Yellow - System Ok  
 Red - No AC Input  
 Green - No DC Output

Note: Power must be turned off before changing voltage jumper

See figures b & c for examples of Master System On/Off Control or Power Supply Control from the Fire Control Panel

**POWER SUPPLY SPECIFICATIONS**

Input Voltage: 115/230 vac @ 60hz  
 Input Current: 0.8 amps Max.

Output Voltage: 12/24vdc. (Regulated)  
 Output Current: 1.5 amps  
 Ripple Voltage: 0.05 Volts Max

Battery Charger Max Current: 0.25 amps  
 Maximum recommended battery size: 7ah  
 Recommended Battery: SDC Model RB12V7  
 (Replace batteries every 3 years)

To determine standby battery capacity refer to Battery Discharge table (INST-BDT)

Suitable Uses:  
 Electric Lock Power Supply  
 Access Control Power Supply

TEST UNIT YEARLY

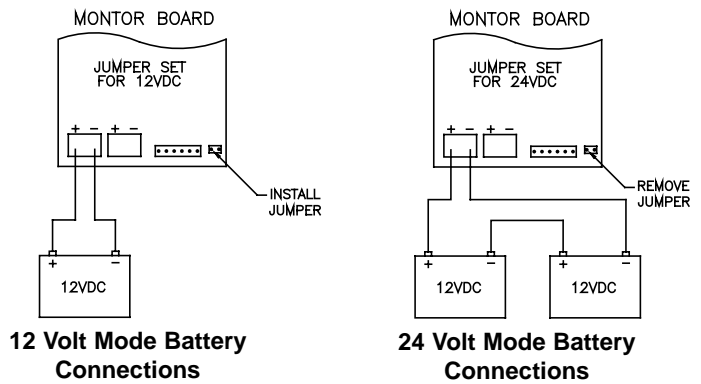

12 Volt Mode Battery Connections

24 Volt Mode Battery Connections

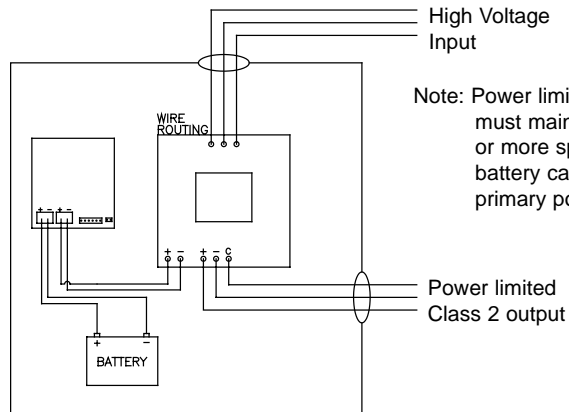

Note: Power limited cable must maintain a 1/4" or more spacing from battery cables or primary power wires.