

# 56- Electric Latch Retraction Exit Devices Installation and Wiring Instructions

With Optional 53- Latchbolt; 55- Request to Exit;  
and TL- (SARGuide) Connection Instructions

**SARGENT**  
**ASSA ABLOY**

## SECTION I: OVERVIEW

### 1. Description

The Sargent 56- prefix ELR works with 80 Series exit devices to provide remote-controlled latch retraction. It is compatible with the following prefixes:

- 53 - Latchbolt Monitor Switch: The latch monitor provides tamper resistant latch monitoring. The monitor switch is activated when there is physical movement of the latch.
- 55 - Signal Switch (Request to Exit): This signal switch monitors the touch bar position. Touch bar monitoring can be used to detect egress, sound an alarm, send a signal to a remote location, or de-energize an electromagnetic lock.
- TL- (SARGuide): Illuminated touchpad for 80 Series exit devices.

Note: The 56- is also compatible with 16-, HK, and 12- mechanical configurations.

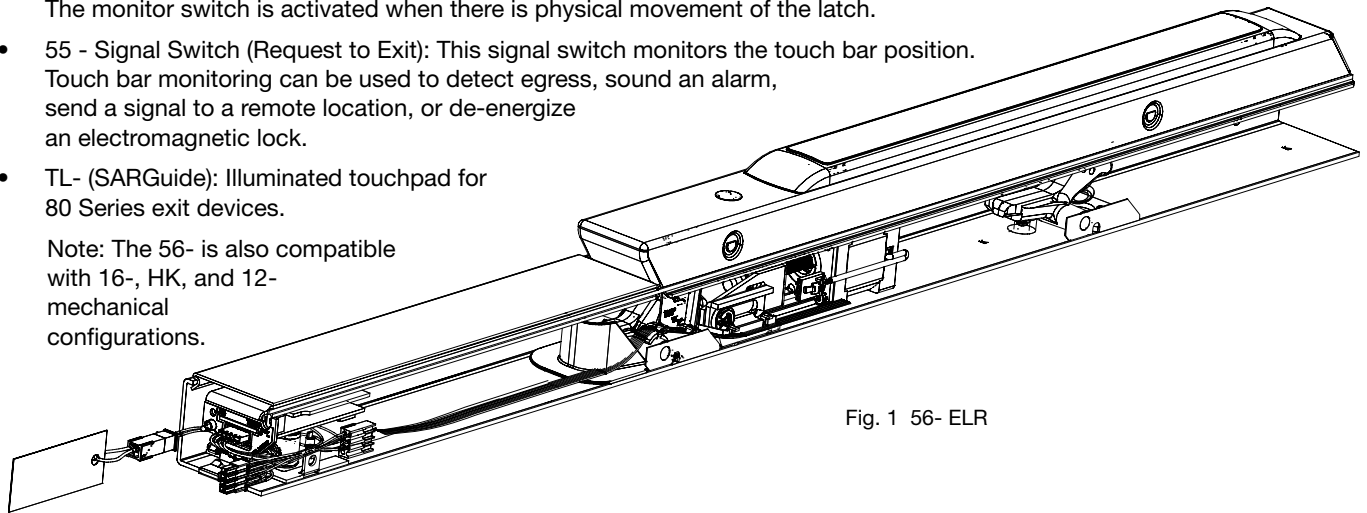

Fig. 1 56- ELR

Sargent Manufacturing Company (New Haven, CT). 2009. Electronic push retraction exit device. U. S. Patent 7,484,777, filed June 30, 2006, and issued Feb. 3, 2009. Additional patent(s) pending.

### 3. Functions

The 56- ELR can be configured to work in either of two modes:

#### POWER MODE (see Section II: POWER MODE)

The device is not energized when locked. When electrified, the push rail and latch(es) will retract and remain in the retracted position until power is removed. Power is typically applied through a relay triggered by an access control device.

#### TIMER MODE (see Section III: TIMER MODE)

The device is always energized and retraction is triggered by a momentary or maintain switch. In **TIMER MODE**:

- When the timer circuit is closed using a **momentary** switch, the device retracts, remains retracted for a set duration, and releases. The duration of the retraction is set though an onboard timer setting.
- When the timer circuit is closed using a **maintain** switch, the device retracts. The device releases when the contact is opened.

### 4. Important

- Caution: Disconnect all input power before servicing.
- Installer must be a trained and experienced service person.
- Wiring must comply with applicable local electrical codes, ordinances and regulations.
- Cylinder (16-) or "hex-key" (HK) mechanical dogging CANNOT be used on FIRE RATED DOORS.

### 5. Installation Notes

- The 56- ELR rail works only with Sargent 80 Series exit devices.
- Always perform mechanical installation, using the appropriate installation instructions, prior to electrical wiring.
- If used in conjunction with M56 or R56 kits, follow instructions A7926 prior to using these instructions.
- Earth Ground: Required for electrostatic discharge (ESD) protection, unless already grounded through the metal door and frame.

FOR INSTALLATION ASSISTANCE CONTACT SARGENT • 1-800-810-WIRE (9473) • [www.sargentlock.com](http://www.sargentlock.com)

# 56- Electric Latch Retraction Exit Devices Installation and Wiring Instructions

With Optional 53- Latchbolt; 55- Request to Exit;  
and TL- (SARGuide) Connection Instructions

## 6. Hinge Requirements

Application	Without Timer		With Timer	
	Wires	Recommended Hinge	Wires	Recommended Hinge
56-	3 wires	QC8	5 wires	QC12
53- 56-	5 wires	QC8	7 wires	QC12
55- 56-	6 wires	QC8	8 wires	QC12
53- 55- 56-	8 wires	QC8	10 wires	QC12
TL-56-	5 wires	QC12	7 wires	QC12
TL-53- 56-	7 wires	QC12	9 wires	QC12
TL-55- 56-	8 wires	QC12	10 wires	QC12
TL-53- 55- 56-	10 wires	QC12	12 wires	QC12

## 7. Wire Gauge Chart

Total One-Way Length of Wire Run (ft)	Load Current @ 24VDC							
	1/4A	1/2A	3/4A	*1A	1-1/4A	1-1/2A	2A	3A
100	24	20	18	18	16	16	14	12
150	22	18	16	16	14	14	12	10
200	20	18	16	14	14	12	12	10
250	18	16	14	14	12	12	12	10
300	18	16	14	12	12	12	10	—
400	18	14	12	12	10	10	—	—
500	16	14	12	10	10	—	—	—
750	14	12	10	10	—	—	—	—
1,000	14	10	10	—	—	—	—	—
1,500	12	10	—	—	—	—	—	—

\*When calculating voltage drop, use 1A as the recommended current draw for the 56- ELR.

## 8. Wire Locations and Positions

56- Electric Latch Retraction devices are supplied with one 4-pin and one 8-pin Molex® connector. Molex connectors allow simple installation using the ASSA ABLOY ElectroLynx® system.

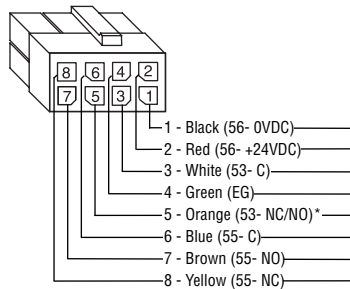

\*NC/NO (Normally Open/Normally Closed) is selectable on controller (refer to 53-Toggle Instructions). Factory preset is NC.

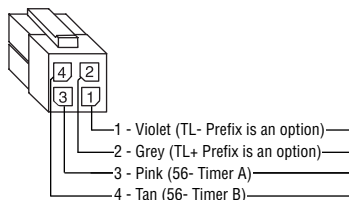

Note: The three inch connector is not included with the product, door, or hinge and must be ordered separately (P/N available in POWER MODE Wiring section).

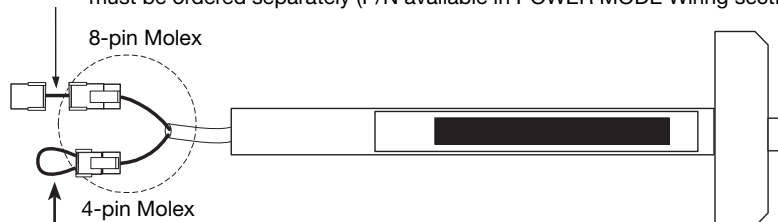

The 56- exit device comes with a pre-assembled shorting jumper (Sargent part number 52-3469). The shorting jumper is required when the device is used in **POWER MODE** (Section II: **POWER MODE**). The shorting jumper must be removed when using the onboard timer (Section III: **TIMER MODE**).

Fig. 2 Wire Color and Position

FOR INSTALLATION ASSISTANCE CONTACT SARGENT • 1-800-810-WIRE (9473) • www.sargentlock.com

# 56- Electric Latch Retraction Exit Devices Installation and Wiring Instructions

With Optional 53- Latchbolt; 55- Request to Exit;  
and TL- (SARGuide) Connection Instructions

## 9. ElectroLynx Wiring System

Hardwiring Made Easy®



### Typical ElectroLynx Wiring Harness Connections

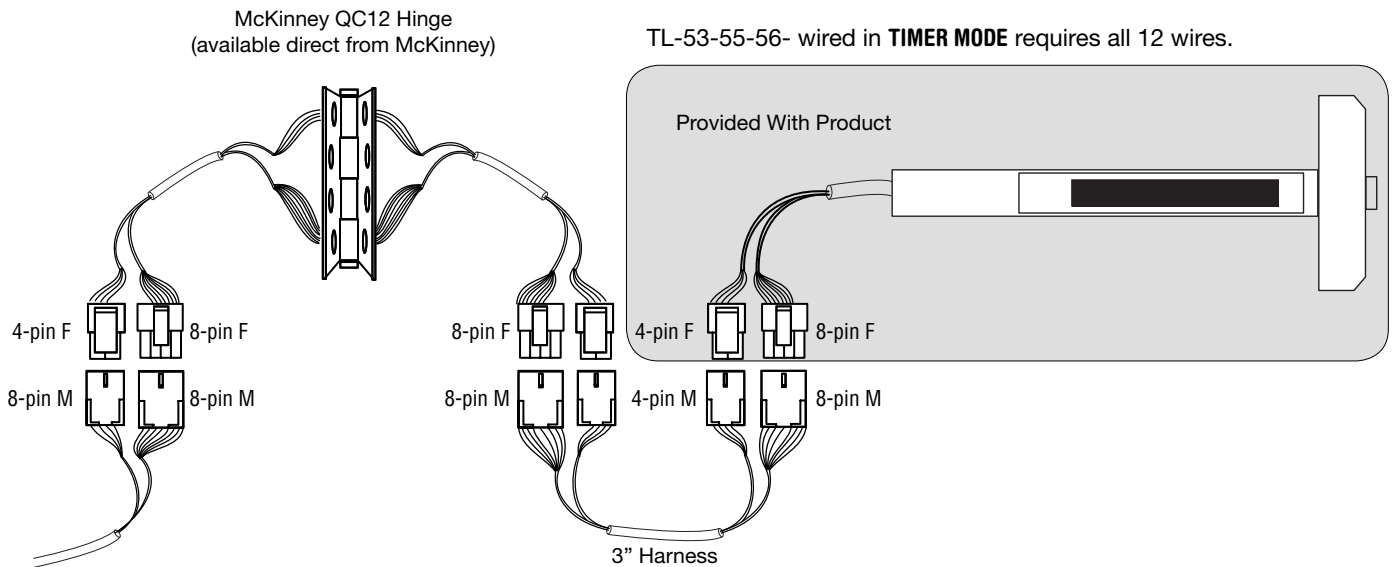

Fig. 3 Typical ElectroLynx Wiring

**IMPORTANT:** ElectroLynx connectors plug and lock together in only one way.  
Do NOT force connectors together.

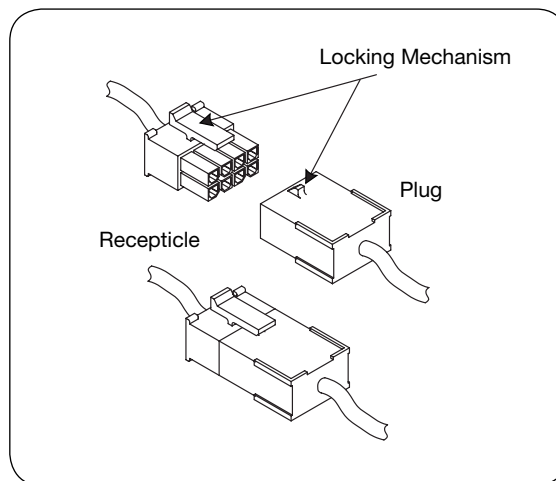

Fig. 4 ElectroLynx Connections

# 56- Electric Latch Retraction Exit Devices Installation and Wiring Instructions

With Optional 53- Latchbolt; 55- Request to Exit;  
and TL- (SARGuide) Connection Instructions

## SECTION II: POWER MODE

In this configuration, the device is not energized when locked. When energized with a 24 volt input, the push rail and latch(es) will retract and remain in the retracted position until power is removed. Power is typically applied through a relay triggered by an access control device.

For installations using the onboard timer circuit, refer to SECTION III: **TIMER MODE**.

### 1. POWER MODE Installation Instructions

How it works: Rail retracts when power is applied and releases when power is removed.

1. Mount 80- Series exit device using mechanical installation instruction sheet(s) provided.

Note: Ensure proper mechanical function before attempting electrical retraction:

- Verify the push rail can be fully depressed and the latch is fully retracted.
- On vertical rod exit devices, verify the latchbolts do not enter hold-back position until the push rail is fully depressed.
- Adjust device mechanically, as required, before applying power.

2. Connect the ElectroLynx harness in the door (Fig. 6 ElectroLynx **POWER MODE** Installation):

- a. Leave the shorting jumper connected to the 4-pin ElectroLynx connector (Fig. 6 ElectroLynx **POWER MODE** Installation).
- b. Plug the 8-pin ElectroLynx connector from the rail into the 3" ElectroLynx harness or splice into non-ElectroLynx harness (Fig. 7 Non-ElectroLynx **POWER MODE** Installation).
- c. Feed the 3" harness through the 1" hole in the door and secure the rail to the door using the mounting bracket and two supplied screws (Fig. 5 **POWER MODE** Installation Diagram).

Note: Do not install the end cap until electrical operation is verified in order to confirm LED signalling.  
Do not discard the end cap and hardware.

3. Connect the ElectroLynx harness to the hinge:

- a. Plug the door harness's 8-pin connector into the hinge's ElectroLynx connector.
- b. Secure the electric hinge to door.

Notes: Make sure no wires are pinched or damaged in the process.

Refer to detailed wiring instructions under **POWER MODE** wiring.

4. Apply 24V according to 56- input requirements (below):

Confirm that the LED is blinking, that the system fully unlocks, and that all bolts clear the strikes. Troubleshoot the device if issues are observed using the steps outlined at the end of the **POWER MODE** section.

5. Store excess wiring under end cap and assemble with provided screws.  
Avoid pinching wires.

#### 56- Input Requirements

- Voltage: 24VDC (22VDC to 28VDC range)
- Filtered and regulated power supply
- Motor operating current: 600mA
- Motor hold current: 250mA

	55- REX	53- LATCH BOLT
Contact Rating (Resistive)	300mA @ 30VDC	2A @ 30VDC
Contact Resistance	150m Ω	30m Ω

Note: Earth Ground is required for Electrostatic Discharge (ESD) protection unless the metal door and frame are already earth grounded; otherwise, earth ground wiring is required at pin 4 (Fig. 6 ElectroLynx **POWER MODE** Wiring).

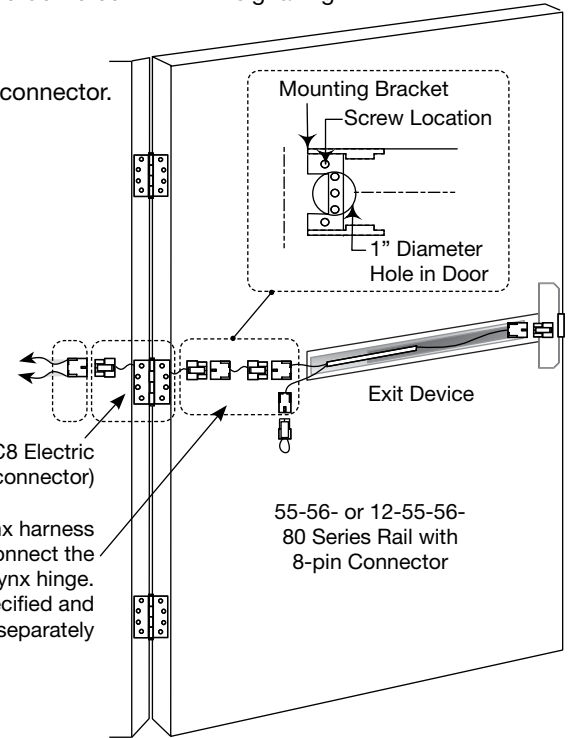

Fig. 5 **POWER MODE** Installation

# 56- Electric Latch Retraction Exit Devices Installation and Wiring Instructions

With Optional 53- Latchbolt; 55- Request to Exit;  
and TL- (SARGuide) Connection Instructions

## 2. POWER MODE Wiring

### ElectroLynx Opening Installation

This is the simplest installation method, requiring the installer to plug the ElectroLynx connectors from the exit device to the Harness to the hinge and then to the pig tail, which is connected to the access control system. Leave shorting jumper installed.

#### Requirements

- 56- Exit device
- 3" ElectroLynx connector harness (not supplied with 56- device)
- McKinney QC ElectroLynx hinge (type of hinge depends on the application)
- ElectroLynx door

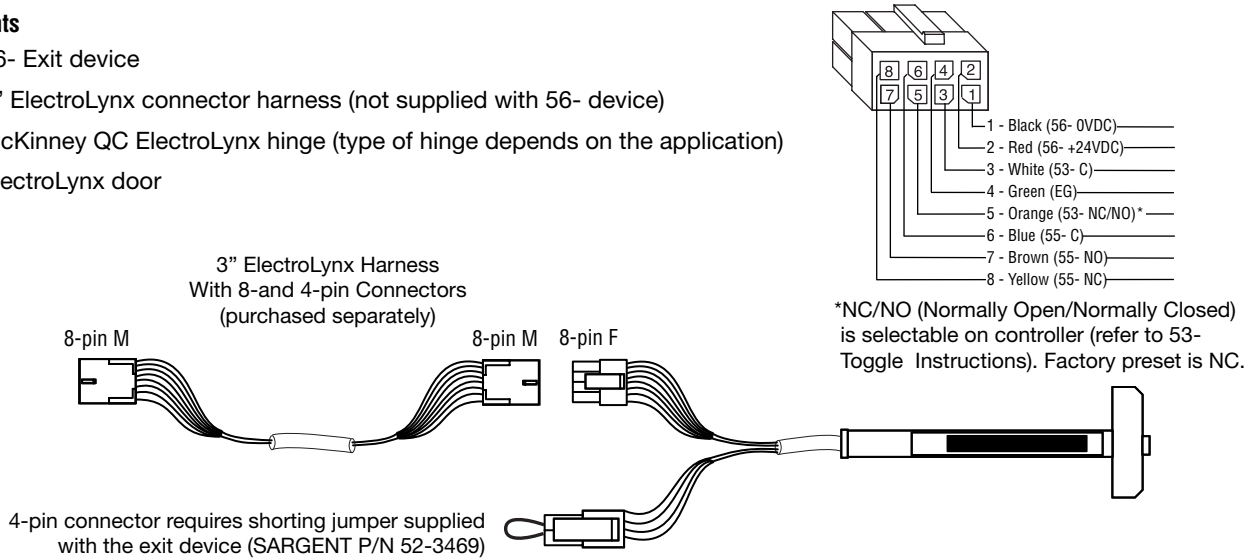

Fig. 6 ElectroLynx POWER MODE Wiring

### Non-ElectroLynx Opening Installation

Standard door with standard electric hinge: Molex connectors with flying leads can be purchased separately (Fig. 7).

	MOLEX BOTH ENDS	MOLEX TO PINS
3 INCH	QC-C003	QC-C003P
6 INCH	QC-C006	QC-C006P
12 INCH	QC-C012	QC-C012P

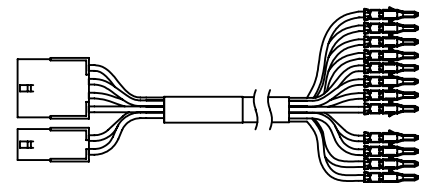

Fig. 7 Molex with 12-pin Connector Pinned

To identify part numbers and order harness(es), visit the McKinney website, [www.mckinneyhinge.com](http://www.mckinneyhinge.com), and search the catalog for ElectroLynx.

If Molex pinned connectors are not available, remove the ElectroLynx connector from the 56- Exit Device and wire nut the 56- wires to the wires from the electric hinge (color coordinating wire colors is recommended). Leave shorting jumper installed.

#### Shorting jumper

The shorting jumper is used in POWER MODE (SARGENT P/N 52-3469).

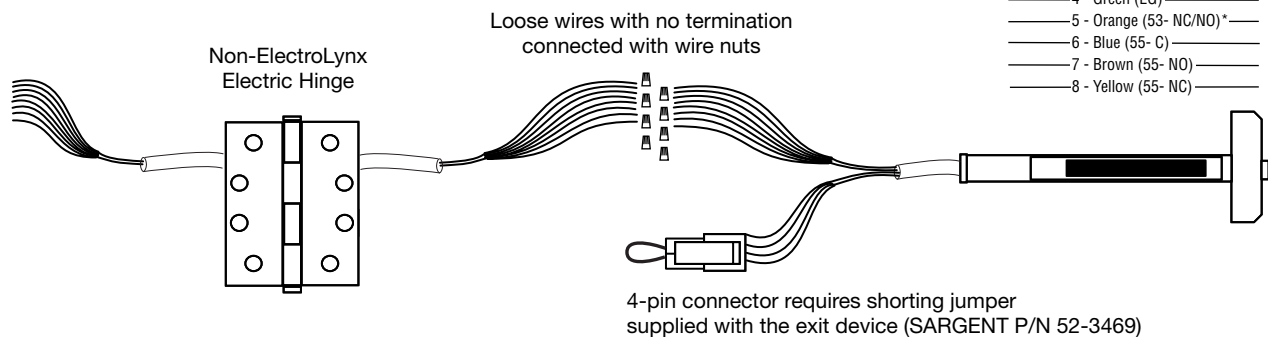

Fig. 8 Non-ElectroLynx POWER MODE Wiring  
56- Wires with ElectroLynx Connector Removed

FOR INSTALLATION ASSISTANCE CONTACT SARGENT • 1-800-810-WIRE (9473) • [www.sargentlock.com](http://www.sargentlock.com)

# 56- Electric Latch Retraction Exit Devices Installation and Wiring Instructions

With Optional 53- Latchbolt; 55- Request to Exit;  
and TL- (SARGuide) Connection Instructions

### 3. POWER MODE Typical Wiring

For use when wiring in **POWER MODE**.

Notes:

- Onboard timer will not function in **POWER MODE**. Add external time delay if necessary.
- The switch is wired between the power supply and the load. Do not cycle the power supply.

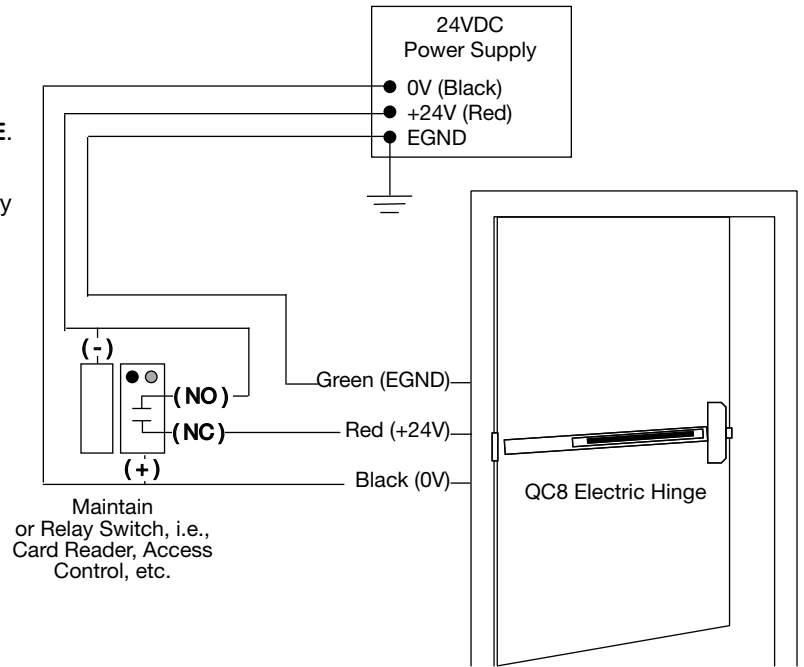

Fig. 9 56- 80 Series Exit Device Typical **POWER MODE** Wiring

### 4. 53- Toggle Instructions

For 56- applications using the optional 53- latchbolt monitor switch (53-56-), pin 5 of the 8-pin ElectroLynx connector will be either a NO contact or NC contact depending on the position of the toggle switch on the motor controller faceplate. Move the switch to the left for NO or to the right for NC.

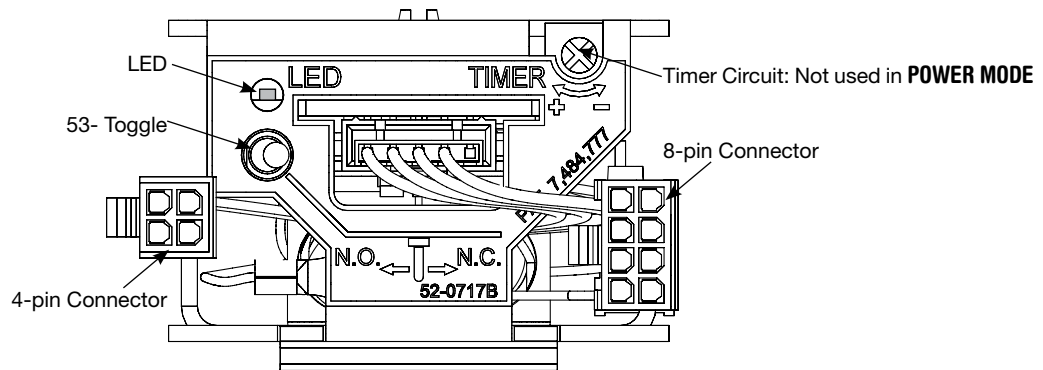

Fig. 10 53-56- Controller

### 5. LED Signalling Chart

SIGNAL	CAUSE	TROUBLESHOOTING
Dark / Unlit	Controller microprocessor is not active	Confirm connections and incoming power
Steady Flashing	Normal operation	Check that POWER MODE jumper is installed
Solid Light	Input voltage is dropping out of operating range	Check wire run and power supply output
2 Flashes Followed by Pause	Retractor sensor problem	Call 800-810-WIRE for assistance
3 Flashes Followed by Pause	Motor mechanism problem	Call 800-810-WIRE for assistance

FOR INSTALLATION ASSISTANCE CONTACT SARGENT • 1-800-810-WIRE (9473) • www.sargentlock.com

# 56- Electric Latch Retraction Exit Devices Installation and Wiring Instructions

With Optional 53- Latchbolt; 55- Request to Exit;  
and TL- (SARGuide) Connection Instructions

## 6. POWER MODE Troubleshooting

Prior to electrical troubleshooting, confirm that the mechanical system properly functions; i.e., that the push bar fully retracts all latches and the door opens freely. Refer to applicable Sargent 80 Series Exit Device product instruction sheet to correct mechanical installation issues.

**IMPORTANT: \*ALWAYS disconnect power before making any mechanical adjustments to the system.**

The push rail does not move when 24V input is applied:
<ul style="list-style-type: none"> <li>o Check inputs to confirm proper voltage and wiring orientation (Fig. 6 ElectroLynx <b>POWER MODE</b> Installation).</li> <li>o Remove end cap from rail and confirm that LED is blinking steadily when power is applied. If not, refer to LED signaling. Note: When configured in POWER MODE, power is released to lock the device (LED will not blink when power is released).</li> <li>o Verify that the 4-Pin Molex shorting jumper is installed (connector with bright orange tag).</li> </ul>
The push rail does not fully retract or push rail retracts completely and holds but does not open door
<ul style="list-style-type: none"> <li>o *Verify mechanical installation and correct as necessary: <ul style="list-style-type: none"> <li>- Is excessive force required to depress the push bar?</li> <li>- Are latches fully clearing the strikes when mechanically cycled?</li> </ul> </li> </ul>
The push rail retracts and unlocks electrically but does not relock:
<ul style="list-style-type: none"> <li>o Physically disconnect power from rail and confirm that input is off.</li> <li>o *Check for mechanical interference (e.g., warped door, lack of shims, misalignment of rail, etc.).</li> <li>o *Was an M56 motor kit installed? Verify the rail assembly.</li> </ul>
Rail behaves abnormally (multiple cycles, clicking, delayed retraction, etc.):
<ul style="list-style-type: none"> <li>o Remove end cap from rail and confirm that LED is blinking steadily when power is applied. If not, refer to LED signaling. Note: When configured in POWER MODE, power is released to lock the device (LED will not blink when power is released).</li> </ul>
For applications using automatic operator(s): Door(s) fail to unlock before doors begin to open:
<ul style="list-style-type: none"> <li>o Adjust timing of operator to allow 750ms for the rail to fully retract.</li> </ul>
53- switch wiring: The design requires normally open functionality and the circuit is normally closed (or visa versa),
There is only a two-wire input for the 53- circuit. Normally open or normally closed configuration is set by toggling the switch on the controller bracket to the required position.
For additional installation assistance, please contact 1-800-810-WIRE (9473). When calling, please provide the following information to improve our service (provide what you can):
<ul style="list-style-type: none"> <li>o Sargent 80 Series Exit Device product type (e.g. 55- 56- 8810).</li> <li>o Your name and contact number.</li> <li>o Location and identification of the affected opening (e.g., site, building, and door number).</li> <li>o Sargent order number (located on product box), if available.</li> <li>o Power supply manufacturer and rated output (i.e., voltage and current).</li> <li>o Method of operation (e.g., <b>POWER MODE</b>).</li> <li>o The number of devices connected to the power supply.</li> <li>o Symptoms of problem (i.e., observed behavior).</li> </ul>

# 56- Electric Latch Retraction Exit Devices Installation and Wiring Instructions

With Optional 53- Latchbolt; 55- Request to Exit;  
and TL- (SARGuide) Connection Instructions

## SECTION III: TIMER MODE

In this configuration, the device is always energized with a 24 volt input and a timer circuit is opened or closed to control rail retraction. A **momentary** or **maintain** switch is typically used to perform this operation.

For installations where the power input is cycled to retract the device, refer to SECTION II: **POWER MODE**.

### 1. TIMER MODE Installation Instructions

How it works: Rail retracts when timer input circuit is closed.

1. Mount 80- Series exit device using mechanical installation instruction sheet(s) provided.

Note: Ensure proper mechanical function before attempting electrical retraction:

- Verify the push rail can be fully depressed and the latch is fully retracted.
- On vertical rod exit devices, verify that the latchbolts do not enter hold-back position until the push rail is fully depressed.
- Adjust device mechanically, as required, before applying power.

2. Connect the ElectroLynx harness in the door (Fig. 11 ElectroLynx **TIMER MODE** Installation):

- a. Remove the shorting jumper from the rail. The shorting jumper is the connector labeled with the orange tag (Fig. 11 ElectroLynx Timer Installation). Do not discard this item.
- b. Plug the 8-pin and 4-pin ElectroLynx connectors from the rail into the 3" ElectroLynx harness or splice into a non-ElectroLynx harness (Fig. 11 **TIMER MODE** Installation).
- c. Feed the 3" harness through the 1" hole in the door and secure the rail to the door using the mounting bracket and two supplied screws (Fig. 11 **TIMER MODE** Installation).

Note: Do not install the end cap until electrical operation is verified in order to confirm LED signalling.  
Do not discard the end cap and hardware.

### 56- Input Requirements

- Voltage: 24VDC (22VDC to 28VDC range)
- Filtered and regulated power supply
- Motor operating current: 600mA
- Motor hold current: 250mA

	55- REX	53- LATCH BOLT
Contact Rating (Resistive)	300mA @ 30VDC	2A @ 30VDC
Contact Resistance	150m Ω	30m Ω

Note: Earth Ground is required for Electrostatic Discharge (ESD) protection unless the metal door and frame are already earth grounded; otherwise, earth ground wiring is required at pin 4 (Fig. 12 ElectroLynx **TIMER MODE** Wiring).

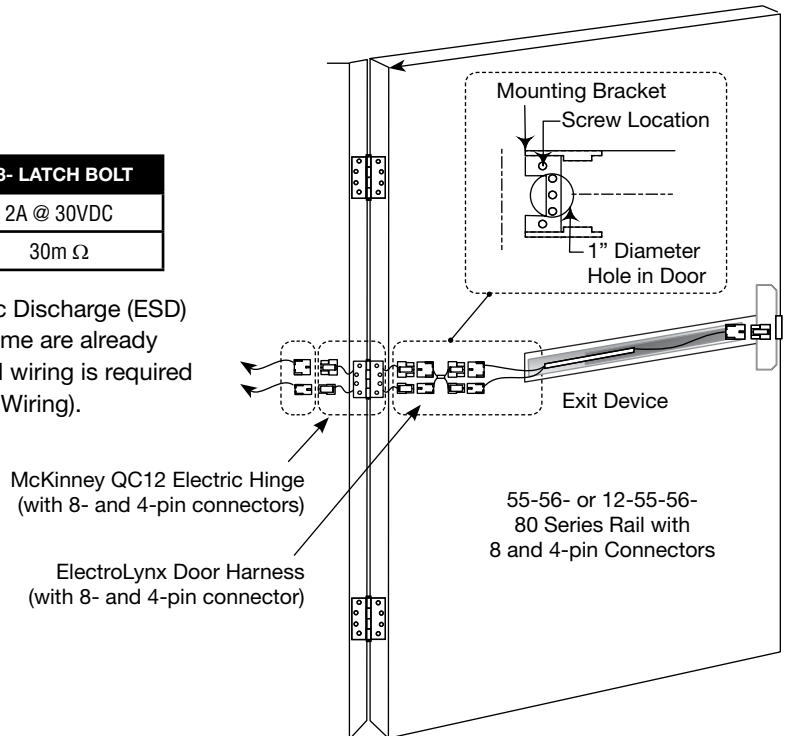

Fig. 11 **TIMER MODE** Installation



# 56- Electric Latch Retraction Exit Devices Installation and Wiring Instructions

With Optional 53- Latchbolt; 55- Request to Exit;  
and TL- (SARGuide) Connection Instructions

## 1. TIMER MODE Installation Instructions (continued)

3. Connect the ElectroLynx harness to the hinge:
  - a. Plug the door harness's 8-pin and 4-pin connectors into the hinge's ElectroLynx connector.
  - b. Secure the electric hinge to door.

Notes: Make sure no wires are pinched or damaged in the process.

Refer to detailed wiring instructions under **TIMER MODE** wiring.

4. Apply 24V according to 56- input requirements:

Confirm that the LED is blinking and close the timer input circuit to retract the device. When the system retracts electrically, confirm that it fully unlocks and that all bolts clear the strikes. Troubleshoot the device if issues are observed using the steps outlined at the end of the **TIMER MODE** section.

5. Store excess wiring under end cap and assemble with provided screws. Avoid pinching wires.

## 2. TIMER MODE Wiring

### ElectroLynx Opening Installation

This is the simplest installation method, requiring the installer to plug the ElectroLynx connectors from the exit device to the harness to the hinge and then to the pig tail, which is connected to the access control system.

#### Requirements

- 56- Exit device
- 3" ElectroLynx connector harness (not supplied with 56- device)
- McKinney QC ElectroLynx hinge (type of hinge depends on the application)
- ElectroLynx door

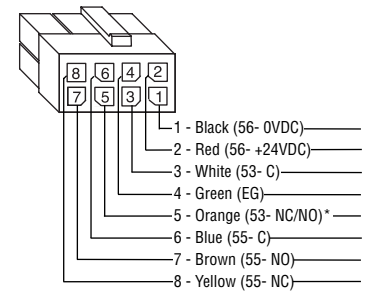

\*NC/NO (Normally Open/Normally Closed) is selectable on controller (refer to 53-Toggle Instructions). Factory preset is NC.

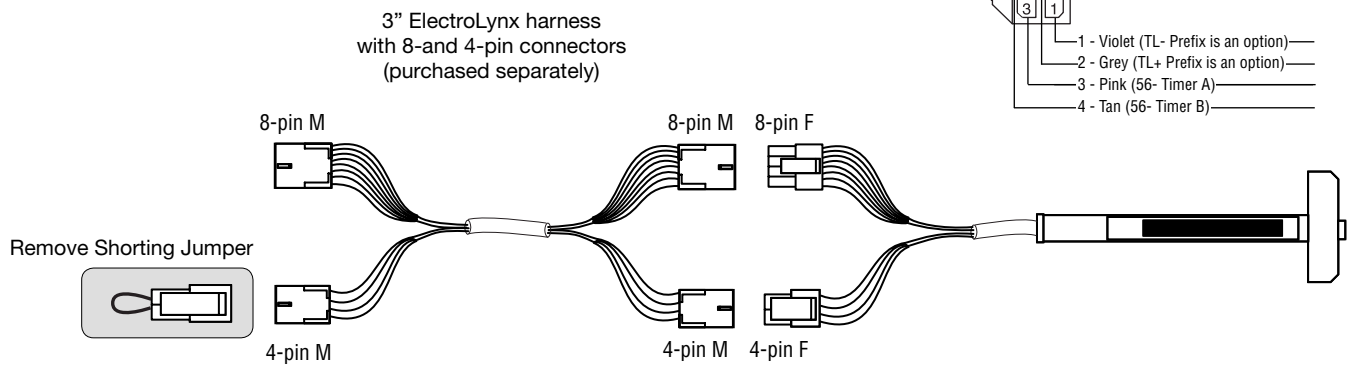
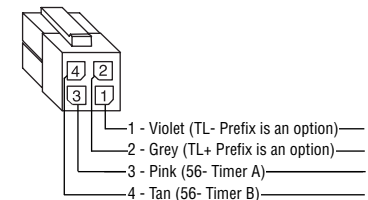

Fig. 12 ElectroLynx **TIMER MODE** Wiring

# 56- Electric Latch Retraction Exit Devices Installation and Wiring Instructions

With Optional 53- Latchbolt; 55- Request to Exit;  
and TL- (SARGuide) Connection Instructions

## 2. TIMER MODE Wiring (continued)

### Non-ElectroLynx Opening Installation

Standard door with standard electric hinge: Remove the ElectroLynx connector from the 56- Exit Device and wire nut the 56- wires to the wires from the electric hinge (color coordinating wire colors is recommended).

	MOLEX BOTH ENDS	MOLEX TO PIN OUT
3 INCH	QC-C003	QC-C003P
6 INCH	QC-C006	QC-C006P
12 INCH	QC-C012	QC-C012P

To identify part numbers and order harness(es), visit the McKinney website, [www.mckinneyhinge.com](http://www.mckinneyhinge.com), and search the catalog for ElectroLynx.

### Shorting jumper

The shorting jumper is used in **POWER MODE** (SARGENT P/N 52-3469).

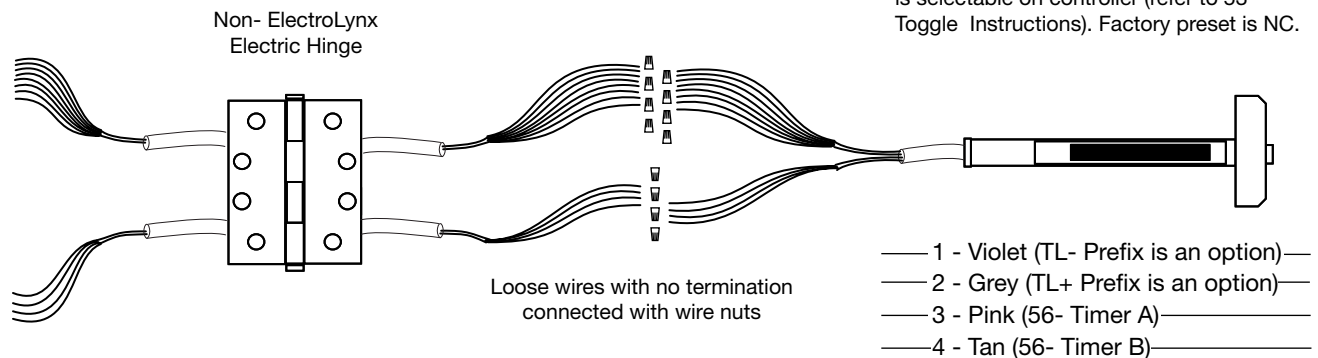

Fig. 13 Non-ElectroLynx **TIMER MODE** Connection  
56- Wires with ElectroLynx Connector Removed

## 3. TIMER MODE Typical Wiring

For use when wiring in **TIMER MODE** (using the onboard timer).

If more than 10 seconds timed delay is necessary, an external timer delay relay is required (not provided).

Note: 24V supply is constant in **TIMER MODE**.

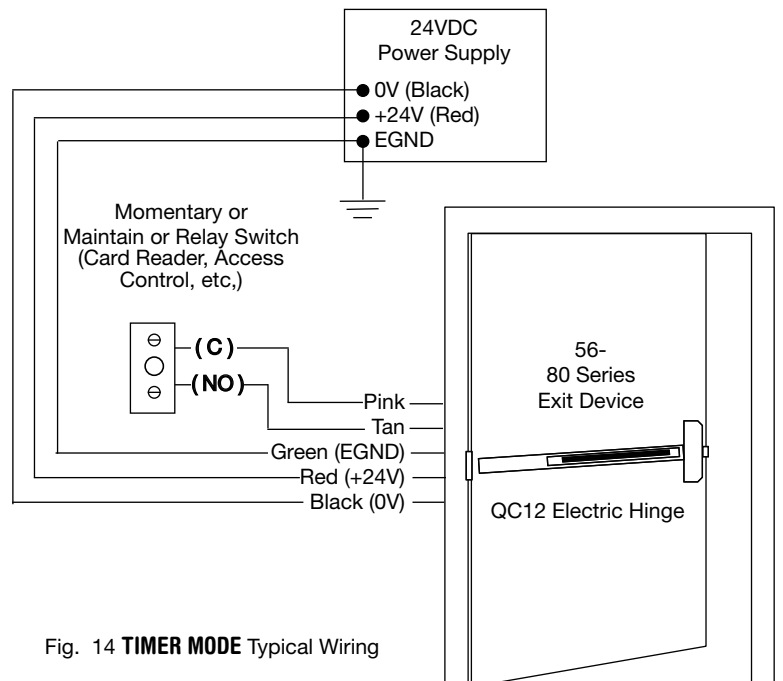

Fig. 14 **TIMER MODE** Typical Wiring

Copyright © 2009 Sargent Manufacturing Company, an ASSA ABLOY Group company. All rights reserved. Reproductions in whole or in part without express written permission of Sargent Manufacturing Company is prohibited.

04/30/09

# 56- Electric Latch Retraction Exit Devices Installation and Wiring Instructions

With Optional 53- Latchbolt; 55- Request to Exit;  
and TL- (SARGuide) Connection Instructions

## 4. TIMER MODE Adjustment (Onboard Timer)

How it works: The 24 volt input is always energized and the system retracts when the timer input circuit is closed.

- When the timer circuit is closed utilizing a **momentary** switch, the device retracts, remains retracted for a set duration, and releases. The duration of the retraction is set using an onboard timer setting (0 - 10 second timer adjustment). The countdown begins when the rail is first retracted.
- When the timer circuit is closed using a **maintain** switch, the device retracts. The device releases when the circuit is re-opened.

Notes:

- Note: 24V supply is constant in **TIMER MODE**. The duration of retraction is determined by whichever is longer: the maintain switch closure or the onboard timer delay.
- If more than 10 seconds delay is necessary (exceeding the maximum setting), an external timer delay relay is required (not provided).

## 5. 53- Toggle Instructions

For 56- applications using the optional 53- latchbolt monitor switch (53-56-), pin 5 of the 8-pin ElectroLynx connector will be either a NO contact or NC contact depending on the position of the toggle switch on the motor controller faceplate. Move the switch to the left for NO or to the right for NC.

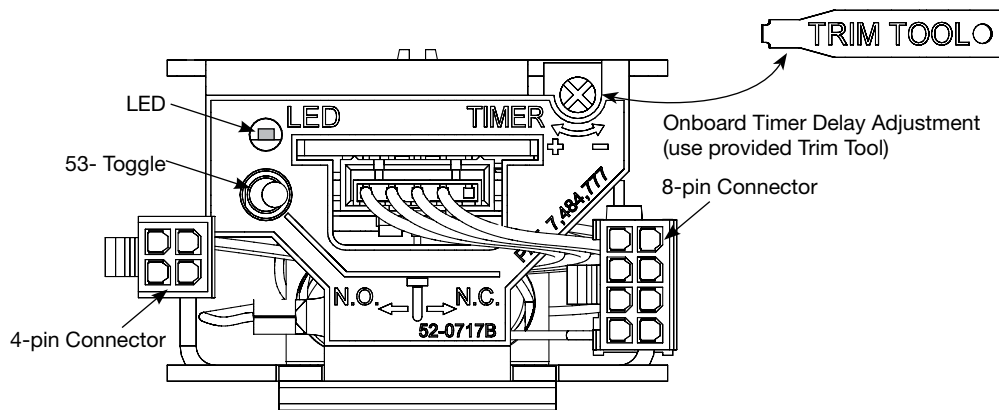

Fig. 15 53-56- Controller With Trim Tool

## 6. LED Signalling Chart

SIGNAL	CAUSE	TROUBLESHOOTING
Dark / Unlit	Controller microprocessor is not active	Confirm connections and incoming power
Steady Flashing	Normal operation	Cycle device by closing the timer circuit
Solid Light	Input voltage is dropping out of operating range	Check wire run and power supply output
2 Flashes Followed by Pause	Sensor or motor issue	Call 800-810-WIRE for assistance
3 Flashes Followed by Pause	Mechanical mechanism issue	Call 800-810-WIRE for assistance

# 56- Electric Latch Retraction Exit Devices Installation and Wiring Instructions

**With Optional 53- Latchbolt; 55- Request to Exit;  
and TL- (SARGuide) Connection Instructions**

## 7. TIMER MODE Troubleshooting

Prior to electrical troubleshooting, confirm that the mechanical system properly functions; i.e., that the push bar fully retracts all latches and the door opens freely. Refer to applicable Sargent 80 Series Exit Device product instruction sheet to correct \*mechanical installation issues.

**IMPORTANT: \*ALWAYS disconnect power before making any mechanical adjustments to the system.**

The push rail does not move when 24V input is applied:
<ul style="list-style-type: none"> <li>o Check inputs to confirm proper voltage and wiring orientation.</li> <li>o When configured for <b>TIMER MODE</b>, 24V must be constantly applied and the timer circuit must be closed to cycle the device.</li> <li>o Remove end cap from rail and confirm that LED is blinking steadily when power is applied. If not, refer to LED signaling.</li> </ul>
The onboard timer duration adjustment is not working
<ul style="list-style-type: none"> <li>o Remove power when making adjustments to the timer delay setting (onboard potentiometer)</li> <li>o When a momentary signal is applied to the timer circuit, the circuit must be reopened for the timer to function.</li> </ul>
The push rail does not fully retract or push rail retracts completely and holds but does not open door
<ul style="list-style-type: none"> <li>o *Verify mechanical installation and correct as necessary: <ul style="list-style-type: none"> <li>- Is excessive force required to depress the push bar?</li> <li>- Are latches fully clearing the strikes when mechanically cycled?</li> </ul> </li> </ul>
The push rail retracts electrically but does not release. System does not relock.
<ul style="list-style-type: none"> <li>o Confirm that the <b>TIMER MODE</b> contact is opened (the rail will remain depressed until the contact is opened).</li> <li>o Physically disconnect power from rail (while electrically retracted) to verify if the issue is mechanical.</li> <li>o *Check for mechanical interference (e.g., warped door, lack of shims, misalignment of rail, etc.).</li> <li>o *Was an M56 motor kit installed? Verify the rail assembly.</li> </ul>
Rail behaves abnormally (multiple cycles, clicking, delayed retraction, etc.):
<ul style="list-style-type: none"> <li>o If a momentary contact is applied to the timer circuit, adjust the onboard timer to a longer duration.</li> <li>o Remove end cap from rail and confirm that LED is blinking steadily when power is applied. If not, refer to LED signaling.</li> </ul>
For applications using automatic operator(s): Door(s) fail to unlock before doors begin to open:
<ul style="list-style-type: none"> <li>o Adjust timing of operator to allow 750ms for the rail to fully retract.</li> <li>o If a momentary contact is applied to the timer circuit, adjust the onboard timer to a longer duration to prevent the device from locking prior to operator actuation.</li> </ul>
53- switch wiring: The design requires normally open functionality and the circuit is normally closed (or visa versa),
There is only a two-wire input for the 53- circuit. Normally open or normally closed configuration is set by toggling the switch on the controller bracket to the required position.
For additional installation assistance, please contact 1-800-810-WIRE (9473). When calling, please provide the following information to improve our service (provide what you can):
<ul style="list-style-type: none"> <li>o Sargent 80 Series Exit Device product type (e.g., 55- 56- 8810).</li> <li>o Your name and contact number.</li> <li>o Location and identification of the affected opening (e.g., site, building, and door number).</li> <li>o Sargent order number (located on product box), if available.</li> <li>o Power supply manufacturer and rated output (i.e., voltage and current).</li> <li>o Method of operation (e.g., <b>TIMER MODE</b>).</li> <li>o The number of devices connected to the power supply.</li> <li>o Symptoms of problem (i.e., observed behavior).</li> </ul>