



280+ SHEARLOCK INSTALLATION AND WIRING

MODELS: 280+ and 280+TRD

280+ Standard model is a concealed electromagnetic shear lock designed to fit standard hollow metal doors and frames. In cases where the top of the door is accessible for adjustment, this lock can be used on top rail type doors. The gap between the armature (in the door) and the magnet (in the frame) is adjusted from the armature with a hex wrench. It can be mounted either horizontally (typical) or vertically for certain applications. Reversible mounting tabs (included) allow for a variety of metal door and frame thickness.

280+ TRD model is a concealed electromagnetic shear lock designed to fit a Aluminum top rail glass doors and open channel hollow metal doors and hollow metal or aluminum frames. It is generally used in cases where the top of the door is not accessible for adjustment. The gap between the armature (in the door) and the magnet (in the frame) is adjusted from the edge of the top rail, through an access hole, with a nut driver or standard screwdriver.

Schlage Lock Company
575 Birch Street
Forestville, CT 06010
technical support: 866-322-1237

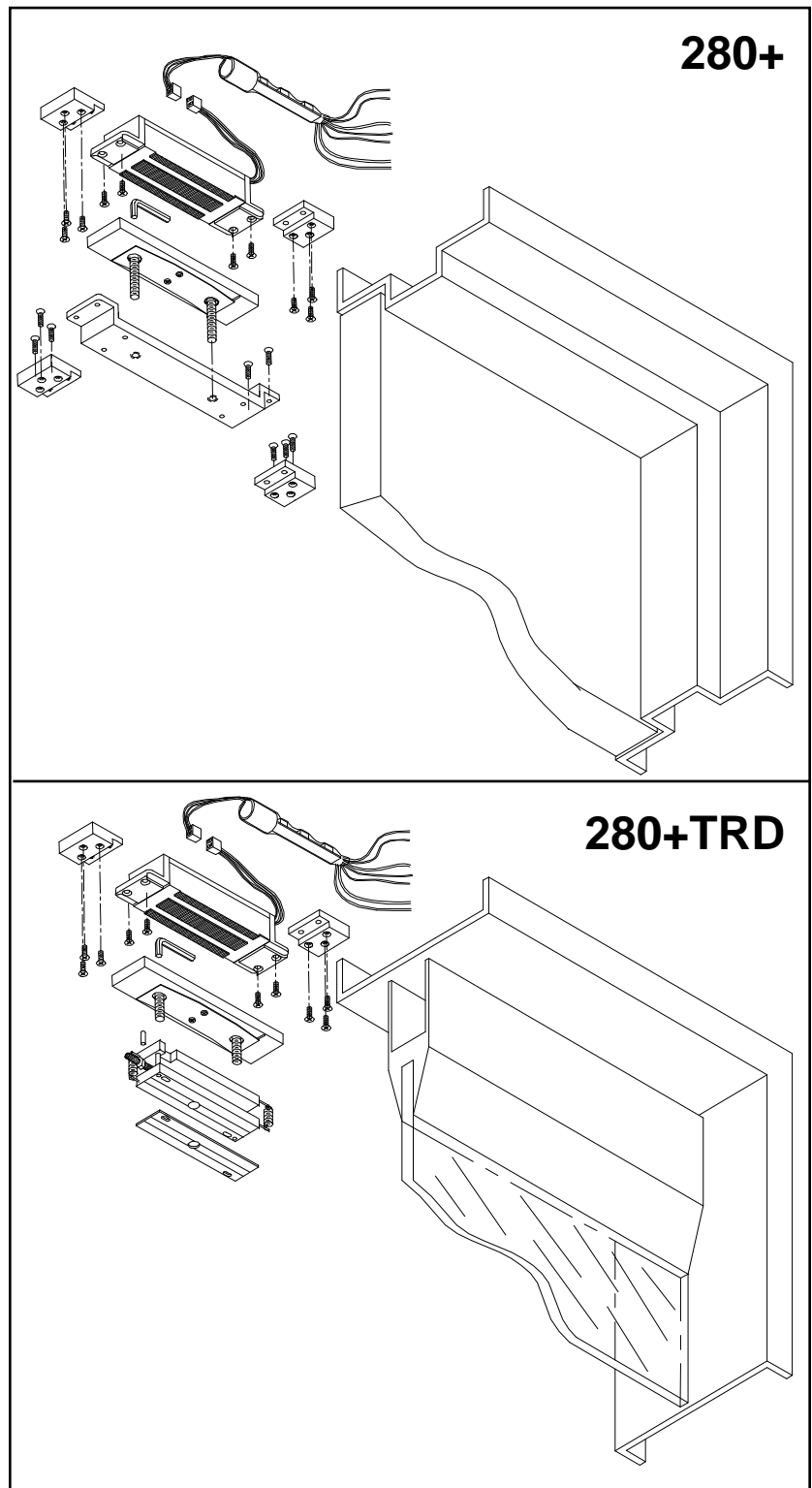



HOW THE 280+ SHEARLOCK WORKS:

A shearlock is designed to rely on the sheer strength of steel for holding force. When energized, the magnet attracts the armature, which moves toward it, overcoming an air gap which allows the door to open without interference. The parts, once engaged, interlock mechanically because of their shape. This gives the system tremendous holding force (in excess of 2700 pounds). Because of the design, door and frame preparation must be done very accurately. It is important that centerlines of the magnet and armature line up to form a vertical axis. (See diagram at top of page 4.) It is also critical that the air gap be adjusted to be as close as possible without interfering with door operation. This will ensure the best possible reliability. The electronic module is designed to have a very strong initial magnetic field, a minimum of 2 seconds after power is reapplied. This will allow the armature to reliably overcome the air gap and ensure positive engagement.

Specifications

Electrical

Input Voltage	<i>Filtered, Regulated 12 to 24 VDC</i> (automatic voltage selection)
Input Current	0.65 Amps Nominal @ 12VDC (Inrush: 2.0 Amps @ 12VDC) 0.20 Amps Nominal @ 24VDC (Inrush: 1.5 Amps @ 24VDC)
Adjustable Time Delay (ATD)	Adjustable from 2 to 30 seconds. Factory default: 3 seconds
Automatic Relock Switch (ARS)	External magnetic reed switch (required for proper operation)
Optional Monitoring Output MBS	Contact rating - 1 Amp maximum at 30VDC

Mechanical

Mounting Type	Mortise mounted horizontal or vertical. Non-handed
Shear Holding Force	2700 lbs.
Door Thickness	1 3/4 " Minimum (except for HD models)
Plating	Magnetic face and armature; nickel plated to resist corrosion

Warranty

Magnetic coil: Lifetime Electronics: 1 year limited

Certifications/Compliance

UL# R12092; MEA# 222-96-E; CSFM# 3774-0544:107

Shipping Weight

280+ - 6 Pounds; 280+TRD/BRD - 8 Pounds

DOOR AND FRAME CENTERLINE IDENTIFICATION:

♦ For proper operation, it is critical that the centerlines of the magnet and armature assembly line up to form a vertical axis. The figure at right shows the centerline scheme for a standard 280+. Note that the centerlines of the magnet (M1 and M2) are directly above the centerlines of the armature assembly (A1 and A2) so that they form a vertical axis (AM).

- ♦ The location of the magnet and armature relative to the latch side is not critical but a minimum of 7 inches from the edge of the door is recommended.
- ♦ The standard model 280+ can be installed in a horizontal or vertical configuration.
- ♦ To achieve maximum resistance to forced entry, position as follows:
 - *Horizontal configuration* - position unit close to the latch side of door jamb.
 - *Vertical configuration* - position unit close to the strike plate.
- ♦ In some applications the door and frame may require reinforcement.

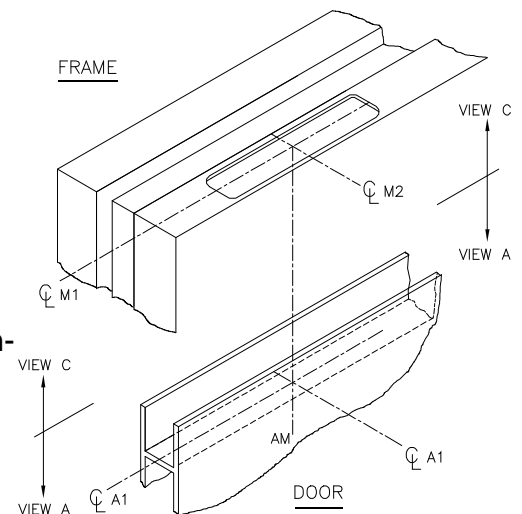
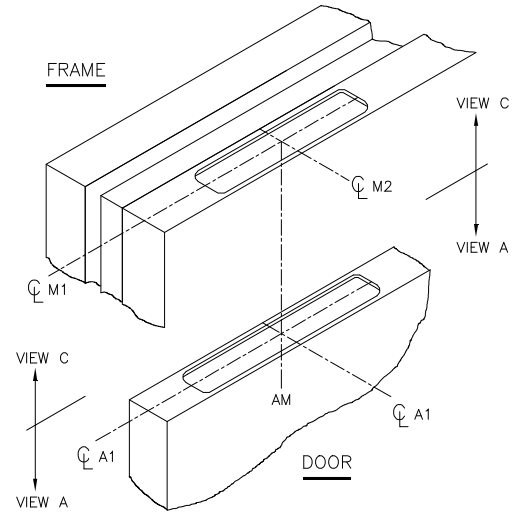

DOOR STATUS SWITCH: This MUST be installed for proper operation. It is best installed as close to the latch side (opposite the hinge side) as possible. The switch indicates to the module that the door is in the closed position so it can lock and engage properly.

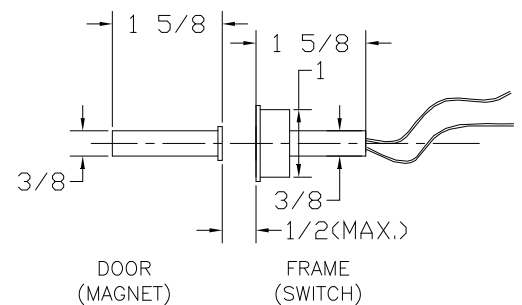
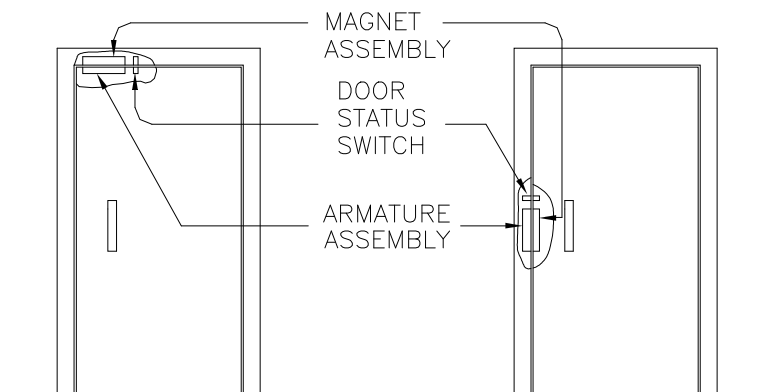

FRAME PREP:

The tabs used for metal frame mounting can be inverted to accommodate different gages of metal. It is very important that the centerlines of the door and frame prep line up to form a vertical axis. The standard paper template (included) is useful in laying out the door and frame prep.

HOLLOW METAL OR ALUMINUM FRAME PREP

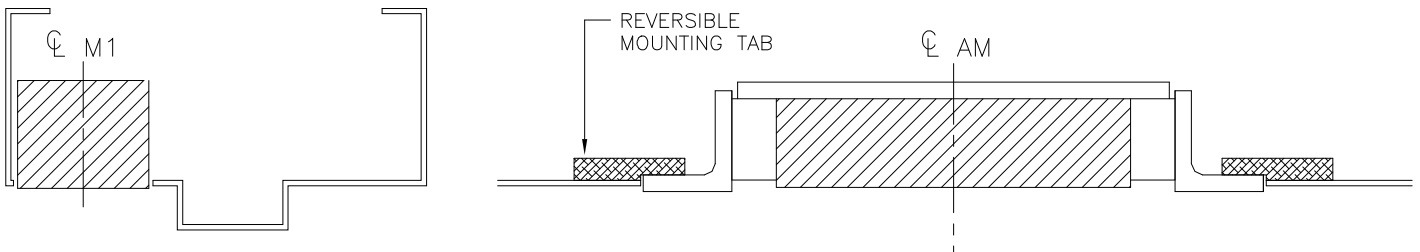
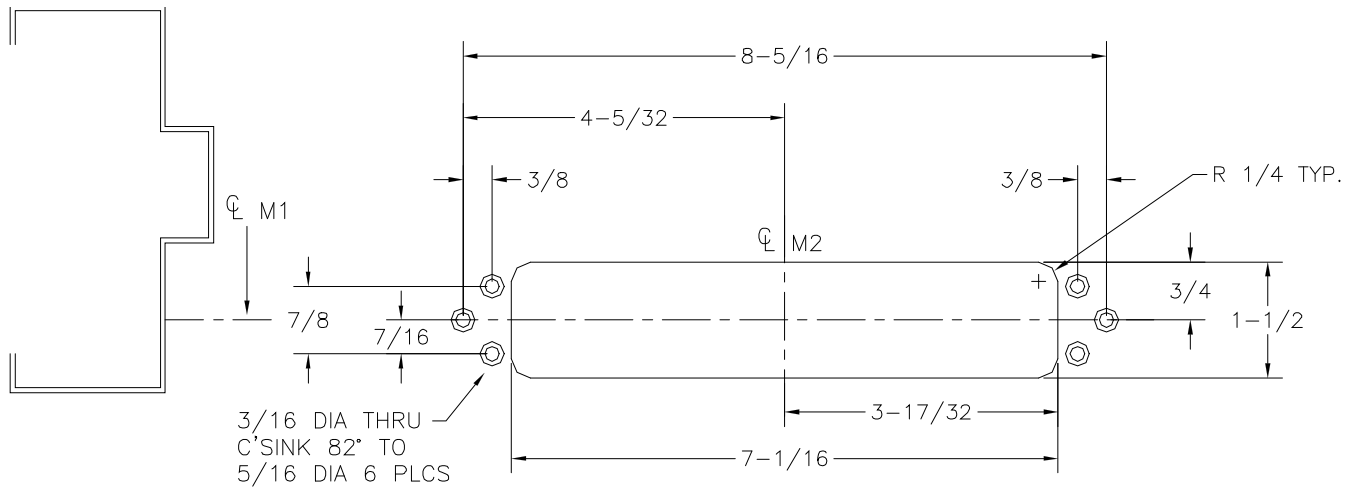

Mounting Tabs

Mounting tabs are reversible so that they may be used with 16 gage hollow metal or 1/8" thick aluminum frames. Observe the correct orientation of reversible tabs as shown.

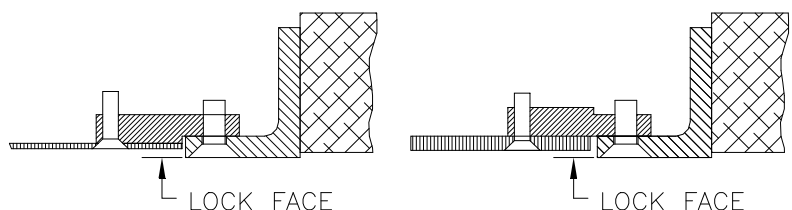

HOLLOW METAL DOOR, CLOSED CHANNEL CONSTRUCTION TEMPLATE INFORMATION:

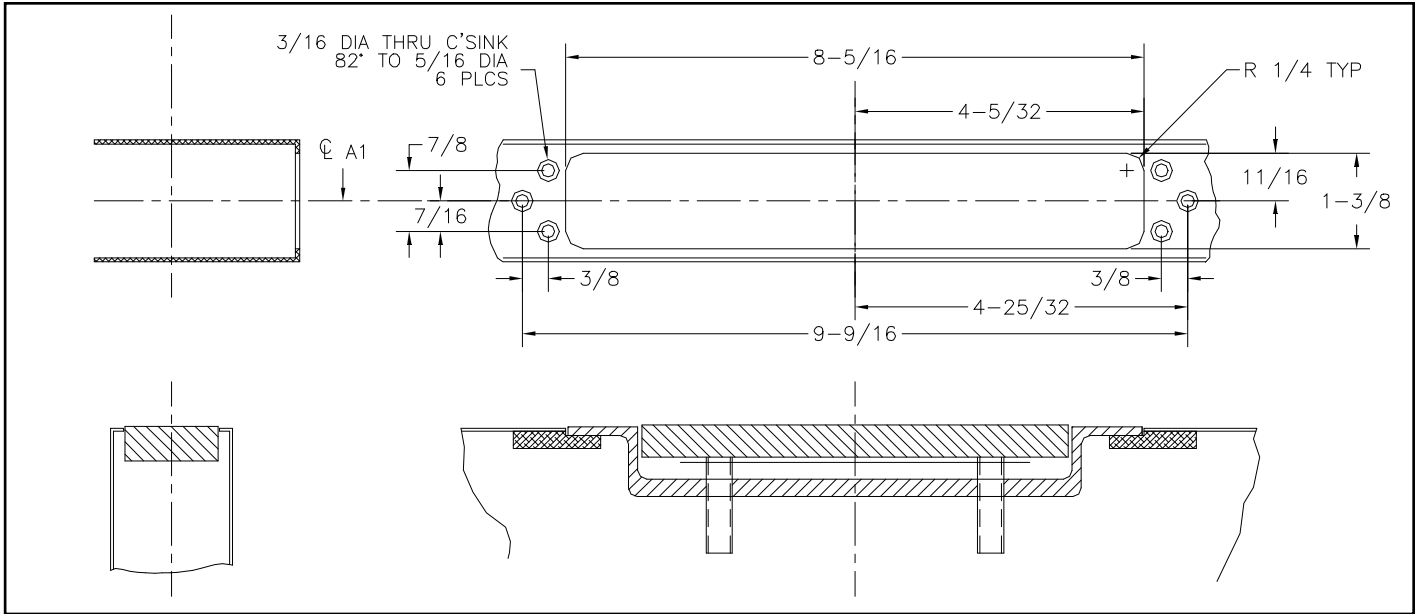

SOLID CORE DOOR TEMPLATE INFORMATION:

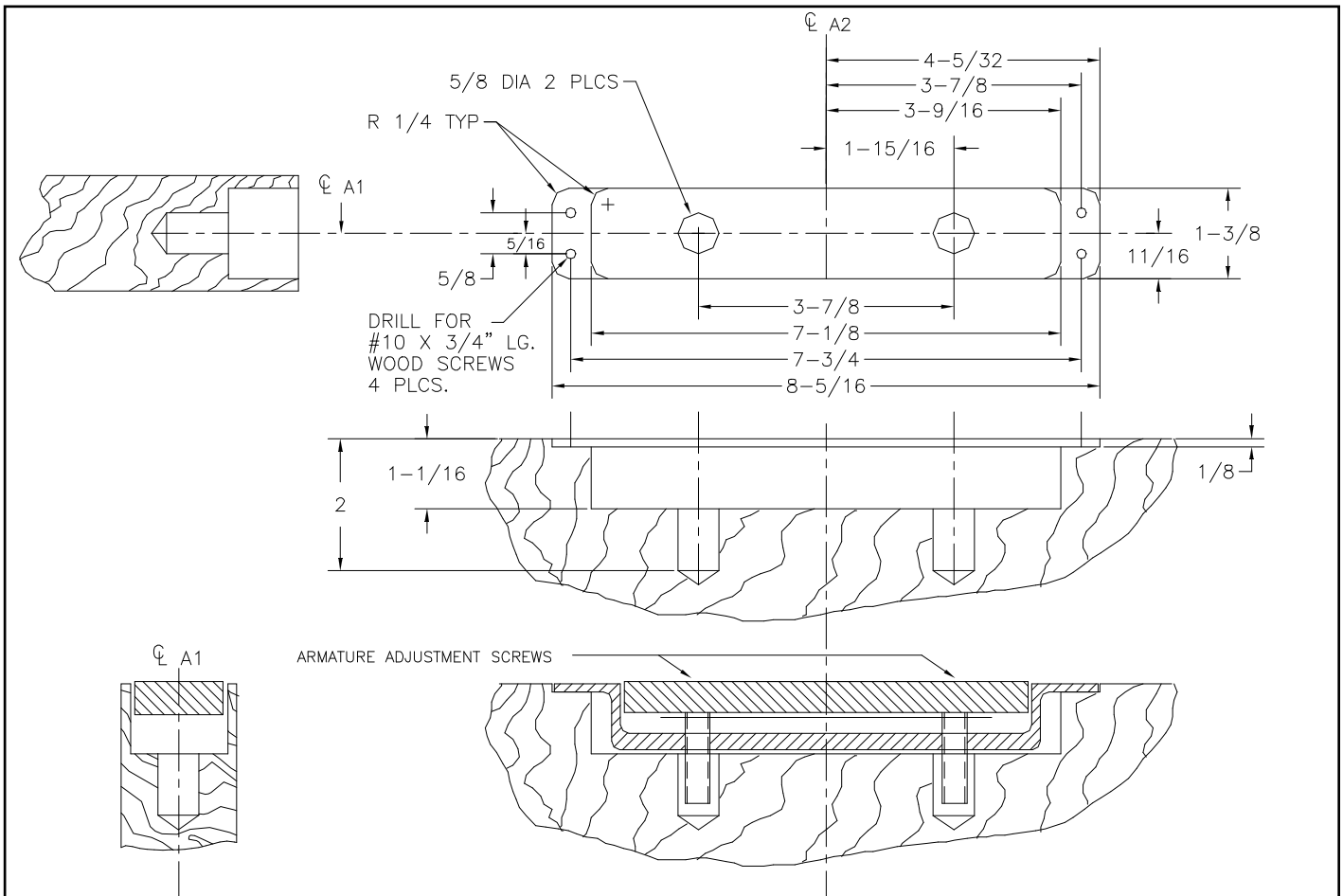

HOLLOW METAL DOOR, OPEN CHANNEL CONSTRUCTION OR TOP RAIL DOOR USING
 STANDARD MODEL LOCK TEMPLATE INFORMATION:

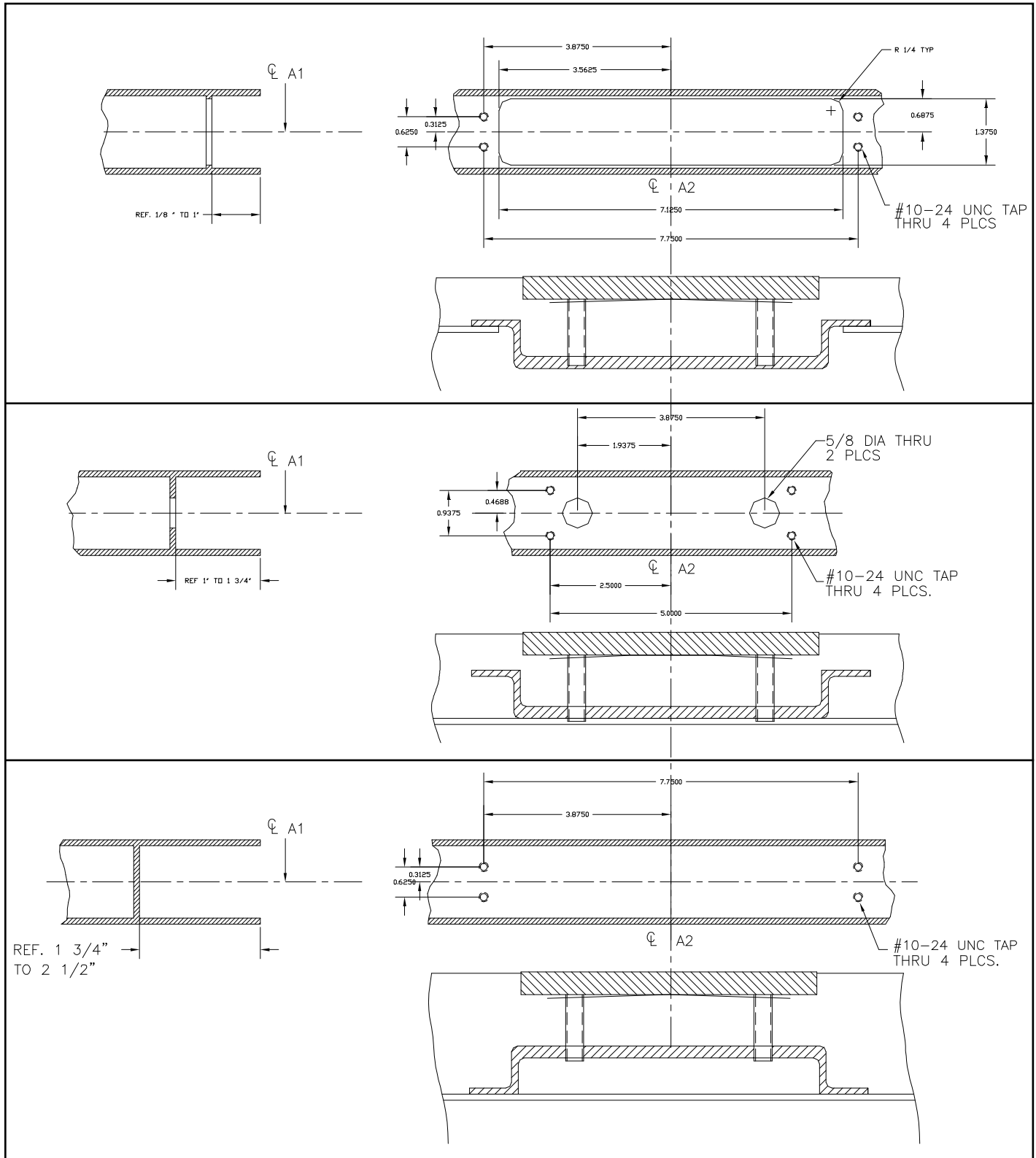

TOP RAIL DOOR (TRD) MODEL TEMPLATE INFORMATION:

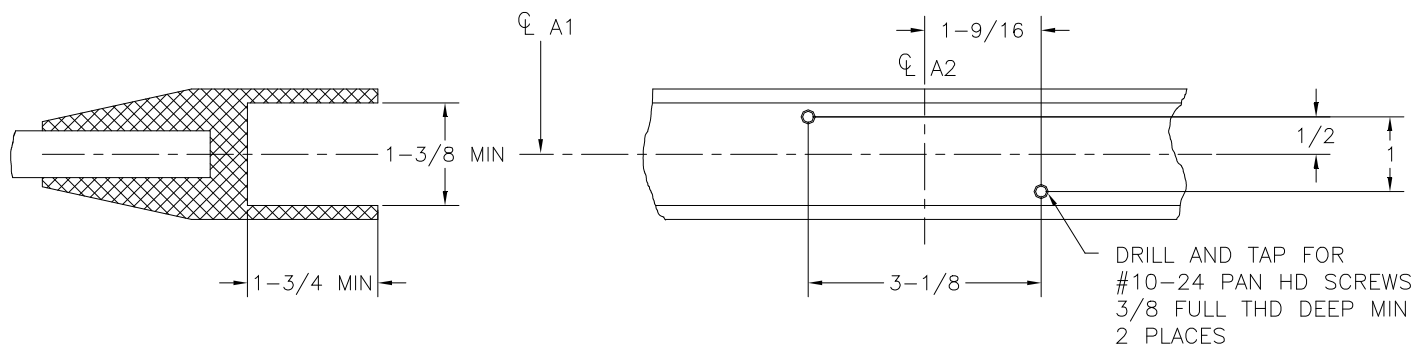

WIRING AND TIME DELAY SETTING:

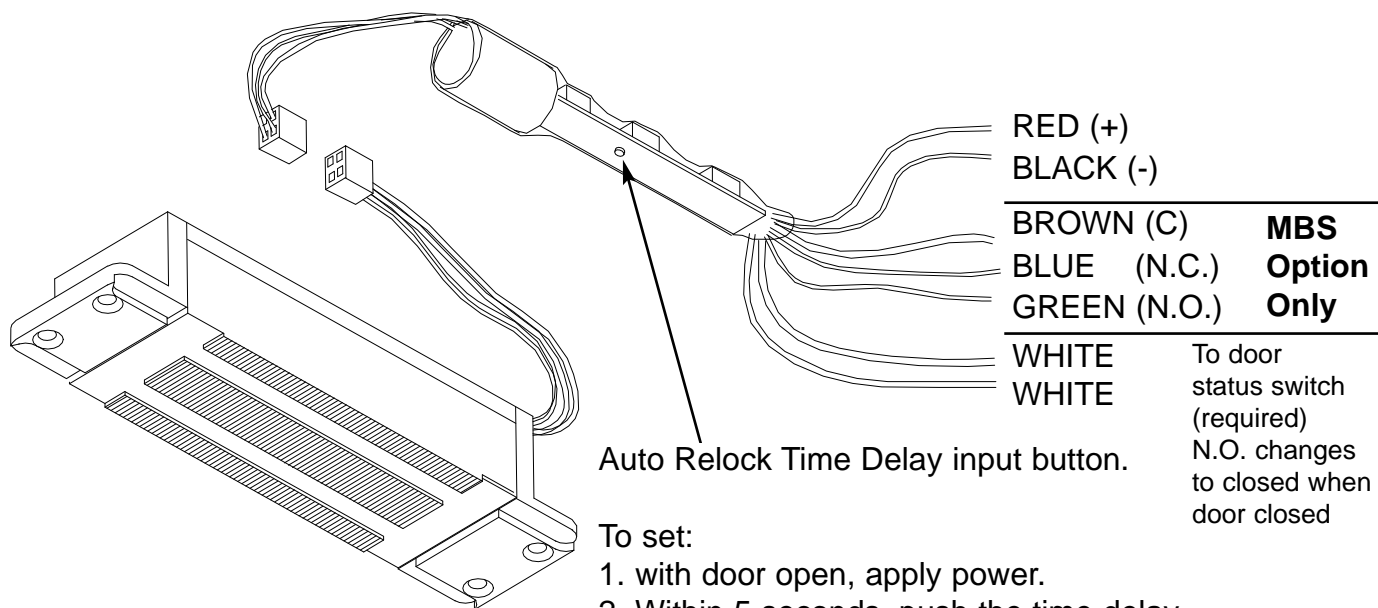

Auto Relock Time Delay input button.

- To set:
1. with door open, apply power.
 2. Within 5 seconds, push the time delay pushbutton once for each second of time delay desired. (Up to 30).
 3. Close the door and verify the delay; minimum delay achievable is 2 seconds due to nature of module.
- Note: the set delay is stored at the door closing and will repeat itself at the subsequent applications of power.



NOTES