



941022-00

Cylinder Preparation

110NL

VON DUPRIN®

Installation Instructions

INSTALLATION INSTRUCTIONS

22 and 98/99 Rim and Vertical Rod Devices (for 55 Rim Device, see other side)

1. Prepare inside face of door for exit device. See exit device instructions for holes, line X-X and center lines.
2. Prepare outside face of door for cylinder.
 - A. Transfer line X-X from exit device side of door to cylinder side of door. Use extra care if edge of door is beveled. Be sure line X-X is parallel to edge of door.
 - B. Locate and prepare all holes as shown.
3. Apply cylinder.
 - A. Cut cylinder tailpiece to proper length.
 - B. Install cylinder and assemble component parts (Figure 1).
4. Apply cylinder mounting screw and tighten.
5. Apply device.
 - A. Remove key from cylinder.
 - B. Attach lock stile case to door.
 - C. Test key action.

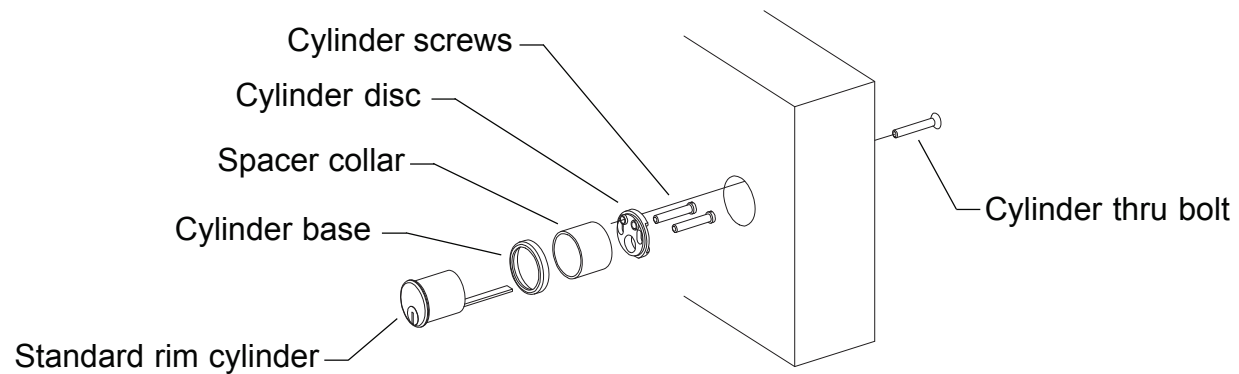
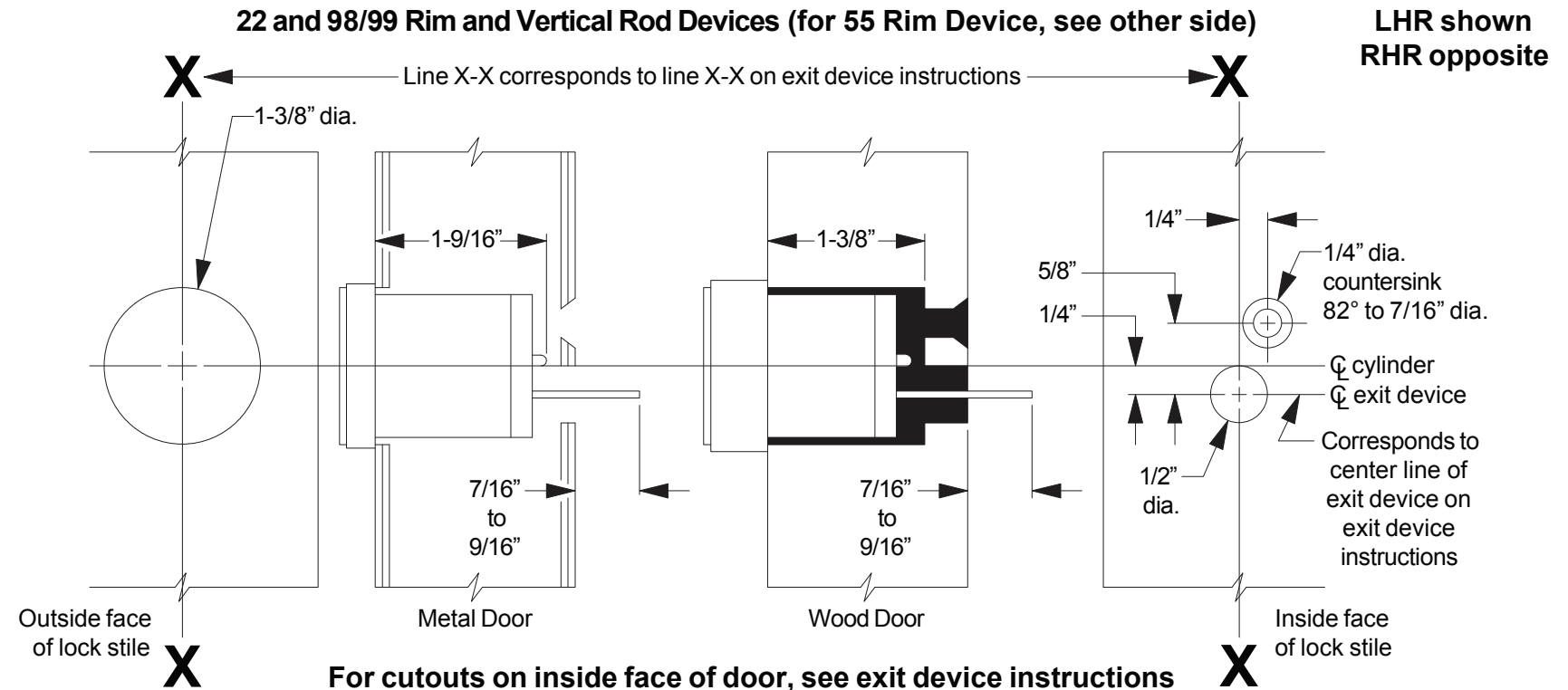

Figure 1

INSTALLATION INSTRUCTIONS

55 Rim Device (for 22 and 98/99 Rim and Vertical Rod Devices, see other side)

1. Prepare inside face of door for exit device. See exit device instructions for holes, line X-X and center lines.
2. Prepare outside face of door for cylinder.
 - A. Transfer line X-X from exit device side of door to cylinder side of door. Use extra care if edge of door is beveled. Be sure line X-X is parallel to edge of door.
 - B. Locate and prepare all holes as shown.
3. Apply cylinder.
 - A. Cut cylinder tailpiece to proper length.
 - B. Install cylinder and assemble component parts (Figure 1).
4. Apply cylinder mounting screw and tighten.
5. Apply device.
 - A. Remove key from cylinder.
 - B. Attach lock stile case to door.
 - C. Test key action.

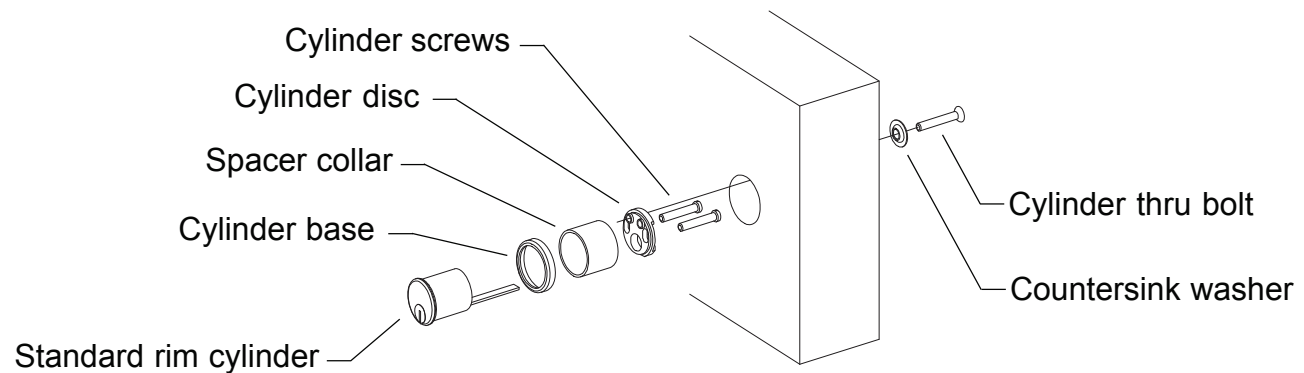
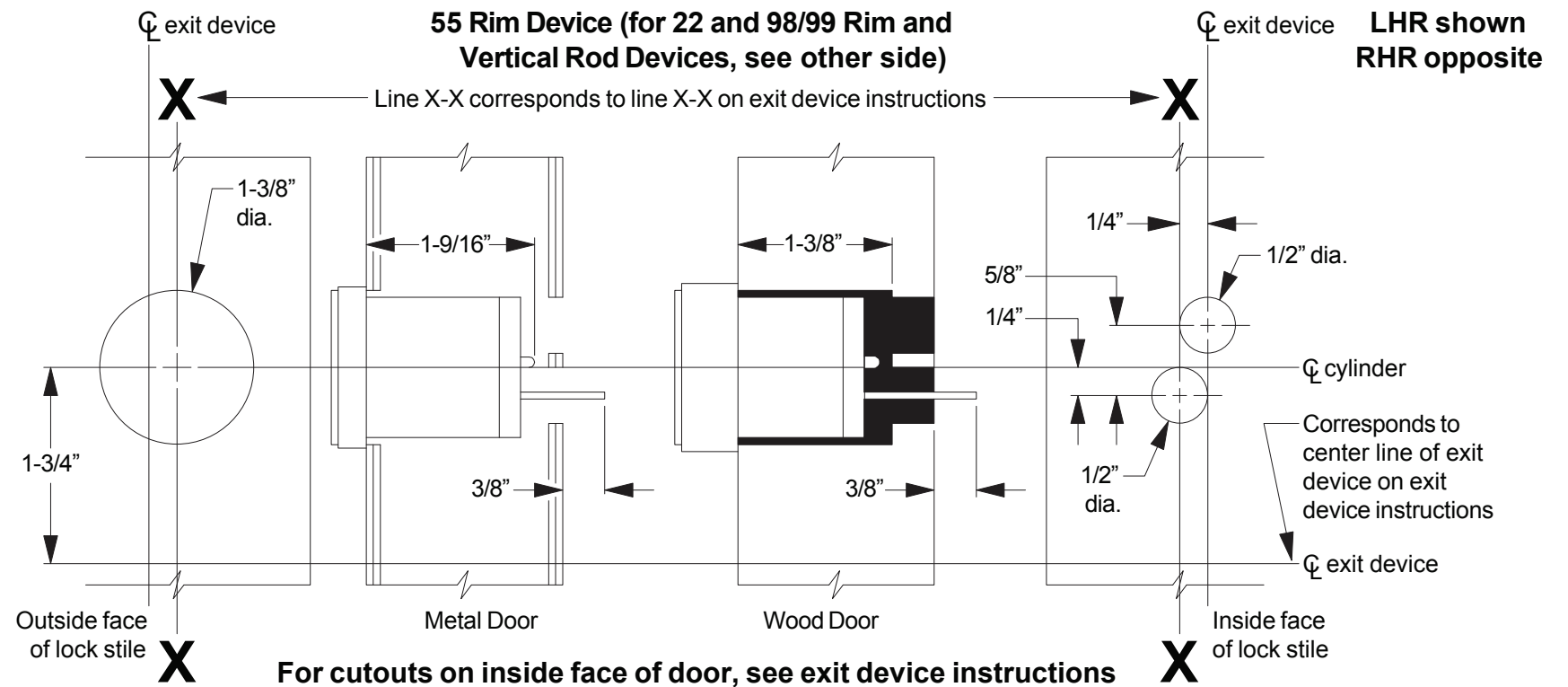

Figure 1