



921028-00

Trim for 5547 concealed vertical rod device

555NL

VON DUPRIN®

Installation instructions

1. Prepare door for exit device. See exit device instructions for holes, line X-X, and center lines.
2. Prepare door for trim:
 - A. Transfer line X-X from inside (exit device side) of door to outside (trim side) of door. Use extra care if edge of door is beveled. Be sure line X-X is parallel to edge of door.
 - B. Locate and prepare all holes as shown.
3. Apply exit device.
4. Change handing of trim if necessary (see Figure 1, other side):
 - A. Dis-assemble trim as shown.
 - B. Position pull grip assembly according to handing of door.
 - C. Re-assemble trim as shown.
5. Install cylinder:
 - A. Cut cylinder tailpiece to length (see Figure 2, other side).
 - B. Install cylinder and assemble component parts (see Figure 1, other side).
6. Apply trim:
 - A. Install trim thru bolt.
 - B. If hole in trim pull base does not line up with mounting screw, loosen pull base sex bolt extension and revolve base to align.
 - C. Install and tighten cylinder thru bolt at top of trim.
 - D. Tighten thru bolt in bottom pull base (see Figure 3, other side).
 - E. Adjust cylinder release bracket to contact trim cylinder cam.

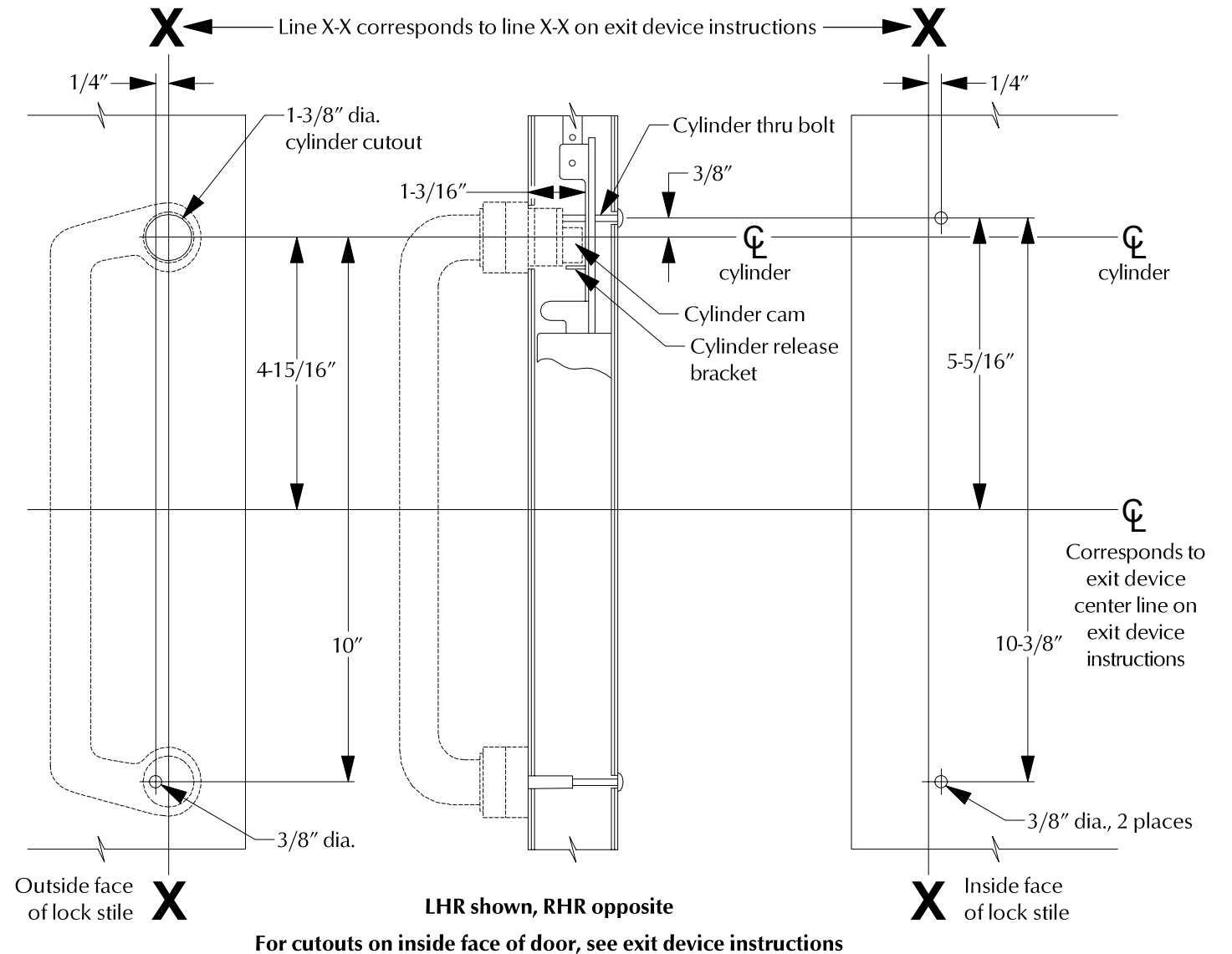

Customer Service
 1-877-671-7011 www.allegion.com/us



© Allegion 2014
 Printed in U.S.A.
 921028-00 Rev. 01/14-b

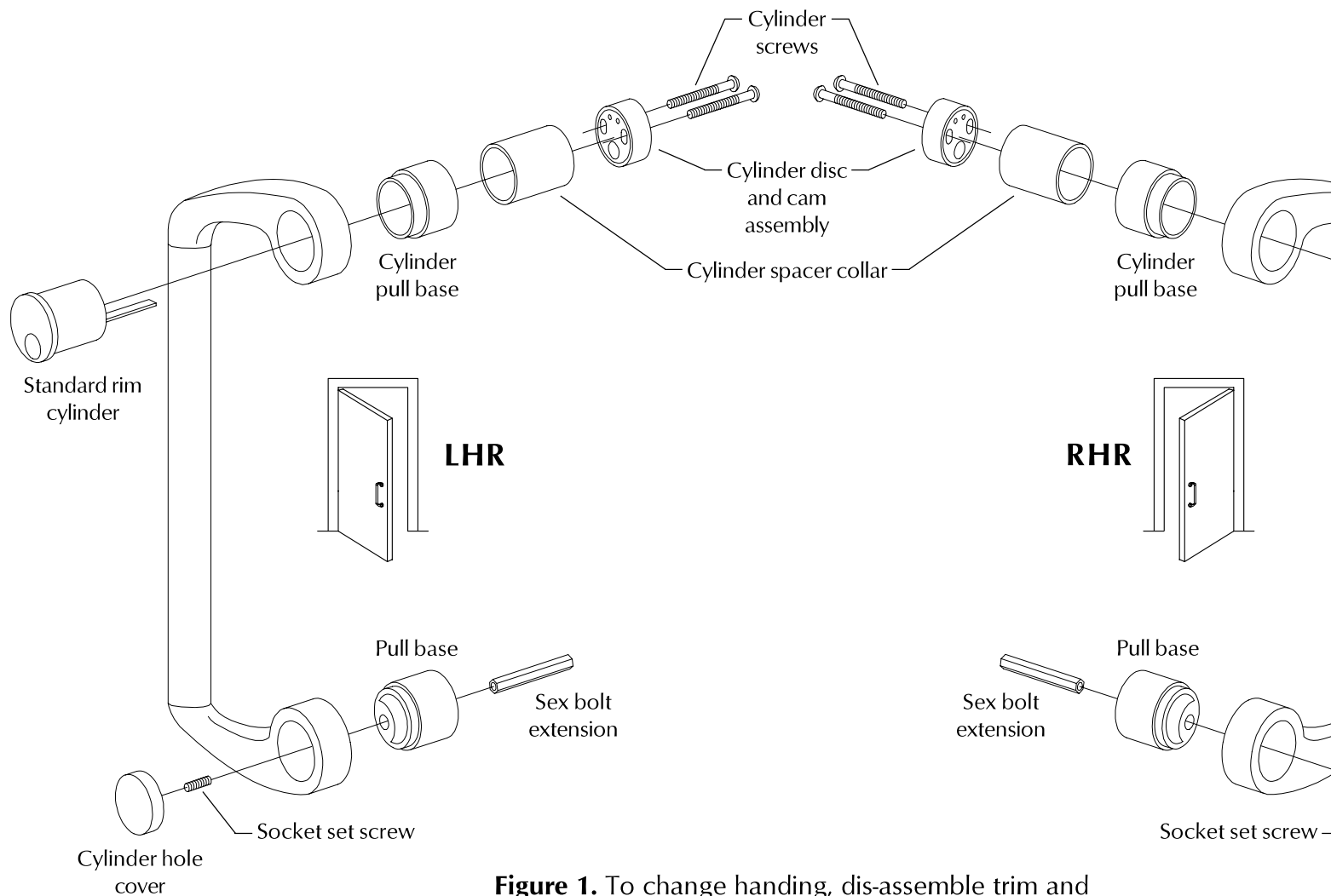

Figure 1. To change handing, dis-assemble trim and re-assemble with pull handle in required position.

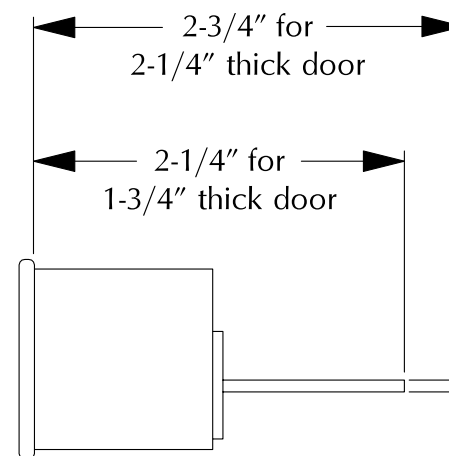

Figure 2. Cut cylinder tailpiece to length.

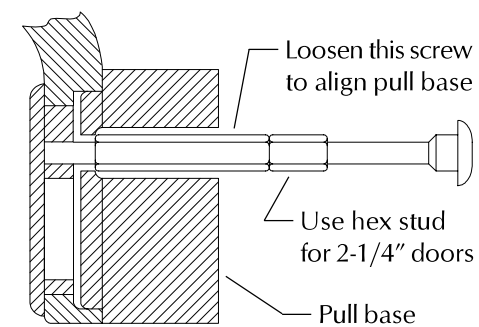

Figure 3. Tighten thru bolt in pull base.