



921101-00

696/697DT/NL

VON DUPRIN®

Trim

Installation Instructions

1. Prepare door for exit device. See exit device instructions for holes, line X-X, and center lines.
2. Prepare door for trim:
 - A. Transfer line X-X from inside (exit device side) of door to outside (trim side) of door. Use extra care if edge of door is beveled.
 - B. Locate and prepare all holes as shown.
3. For NL trim with 98/99 Rim, 98/9927, or 98/9947 exit device:
 - A. Install cylinder (Figure 1).
 - B. Cut cylinder tailpiece to extend 7/16" to 9/16" out of exit device side of door.
 - C. Install tailpiece guide in exit device cam (Figure 2).
4. Apply trim.
5. Apply exit device or 330/350 Push Bar.

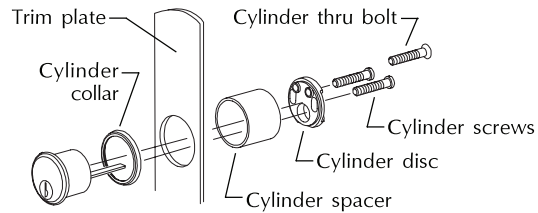

Figure 1

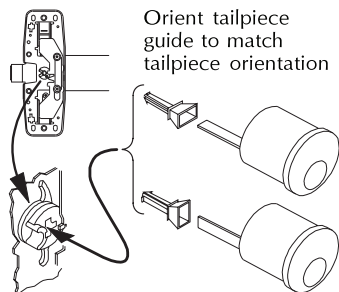
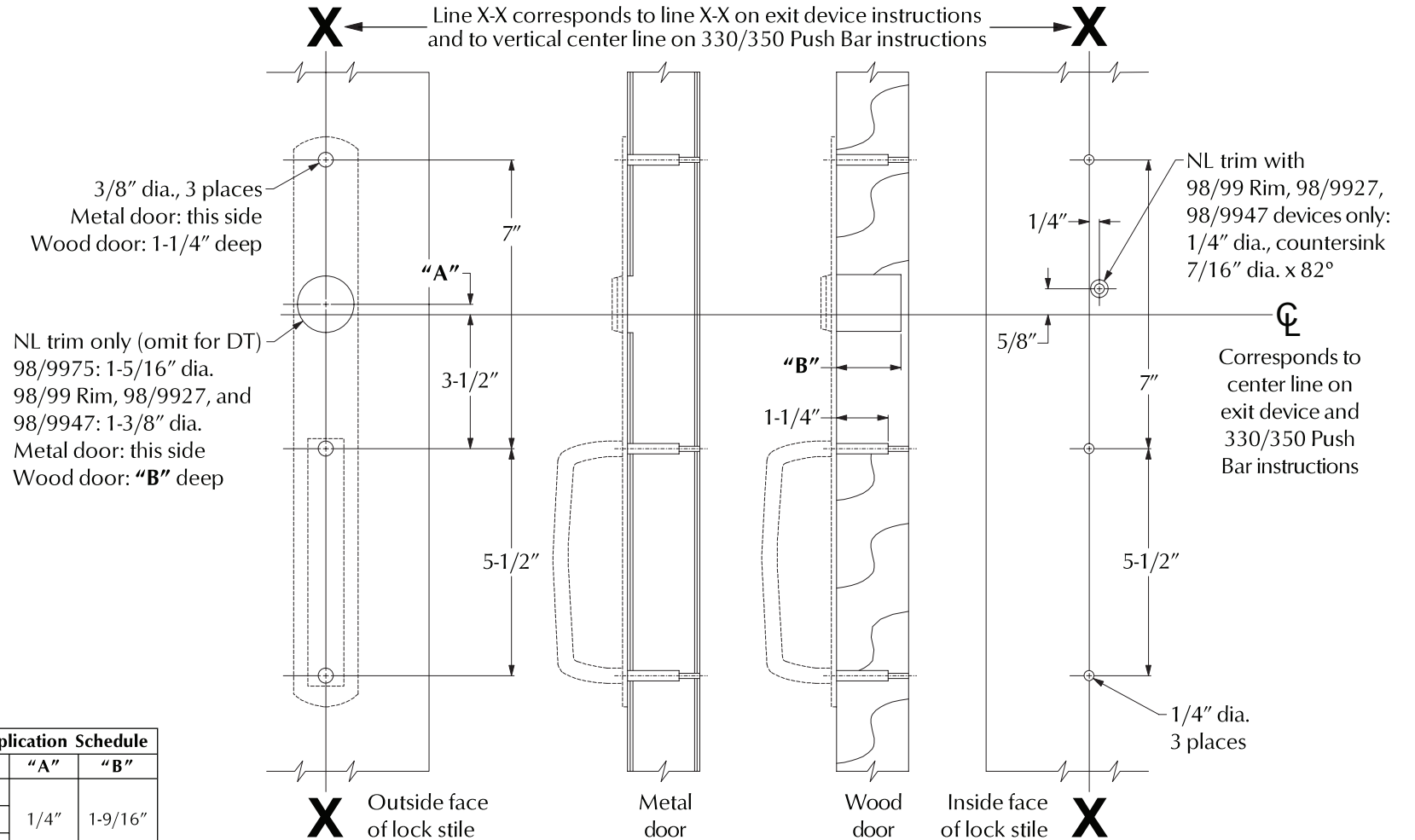

Figure 2

| Device Application Schedule | | |
|-----------------------------|--------|---------|
| Device | "A" | "B" |
| 98/99 Rim | | |
| 98/9927 | 1/4" | 1-9/16" |
| 98/9947 | | |
| 98/9975 | 2-1/4" | 3/4" |
| 330/350 Push Bar | N/A | N/A |



NL trim only (omit for DT)
 98/9975: 1-5/16" dia.
 98/99 Rim, 98/9927, and 98/9947: 1-3/8" dia.
 Metal door: this side
 Wood door: "B" deep

LHR shown, RHR opposite

For cutouts on inside face of door, see exit device instructions

Customer Service
 1-877-671-7011 www.allegion.com/us

