



941061-00

Keyed Removable Mullion

# KR54-F, KR9854 & KR9954

# VON DUPRIN®

Installation Instructions

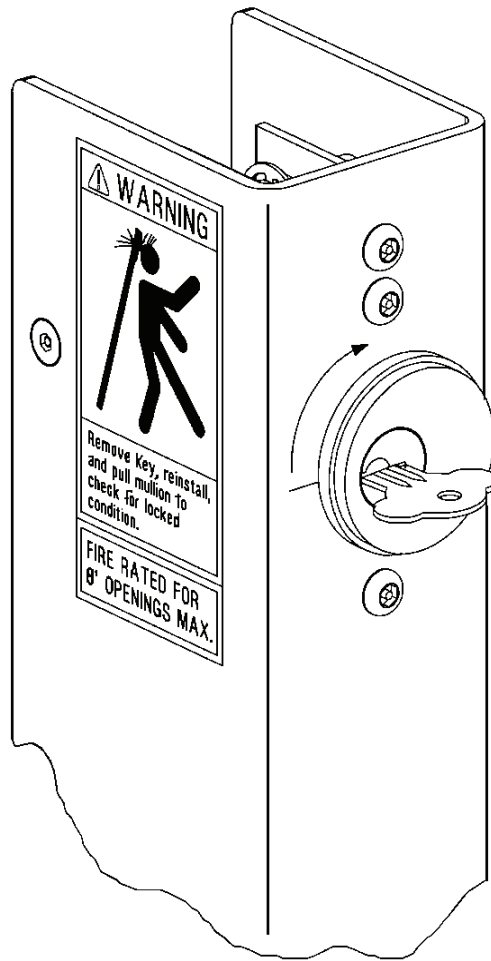

## Read All Warnings Before Starting Installation!

### Index:

• General Information -----	2
• Specifications -----	2
• Warnings -----	2
• Tools Needed -----	2
• Parts List -----	3
• Installation -----	4

## **GENERAL INFORMATION**

These instructions are presented in step-by-step sequence as an aid to preparing for device mounting.

Please review the first two pages carefully which will help identify the hardware and define the terminology used throughout.

## **SPECIFICATIONS**

Fire rated for 8' openings maximum.

***Read All Warnings Before Starting Installation!***



## **TOOLS NEEDED**

**These are the necessary tools for installing an EPT into a factory-prepped door and frame.**

Block wood  
1/16" Allen wrench  
Center Punch  
Drill  
11/32" Drill bit  
13/32" Drill bit

Phillips screwdriver  
Straight-blade screwdriver  
Hack saw  
Hammer  
Measuring tape  
5/16" Tap

# PARTS LIST

This kit contains the following parts (not to scale):

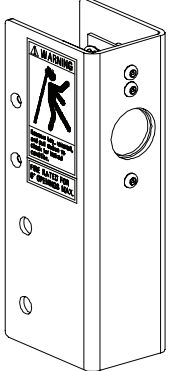

Locking mullion assembly

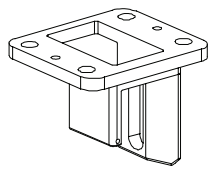

Top mullion fitting

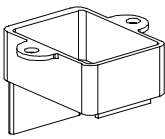

Fusible spacer

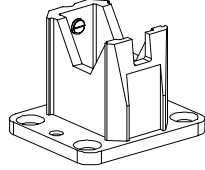

Bottom mullion fitting  
(KR9854, KR9954 & blank only)

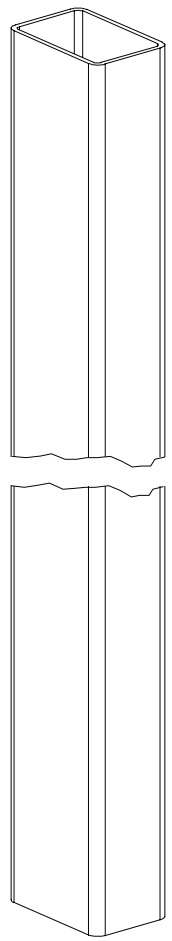

Mullion body  
(KR9854, KR9954 and blank only)

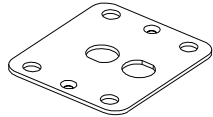

Electric shim plate



Cylinder lock nut



Cylinder locking washer

These parts come with KR9854 only



Frame Connector

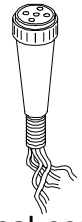

Electrical connector





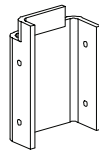

5/32 Security hex key

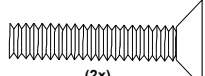
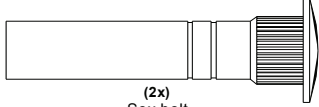
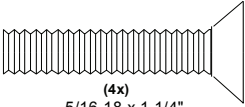
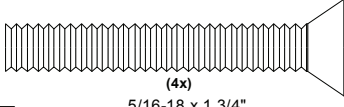

Back cover plate

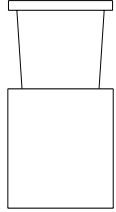
## Screw Legend (to scale)

 (2x) 1/4 -20 x 1" Flat head socket security machine screw	 (2x) Sex bolt
 (4x) 5/16-18 x 1 1/4" Flat Phillips head machine screw	 (4x) 5/16-18 x 1 3/4" Flat Phillips head machine screw (KR9854, KR9954 & blank only)
 (4x) 8-32 x 1/4" Undercut Phillips head socket security machine screw	 (2x) 5/16-18 Expansion anchor (KR9854, KR9954 & blank only)
 (1x) 8-32 x 3/8" Set screw	 (2x) 1/4-20 x 3/8" Phillips pan head machine screw

# INSTALLATION

## 1 Prepare the keyed removable unit.

- 1.1 Position cylinder locking washer over mortise key cylinder hole.
- 1.2 Insert mortise key cylinder through collar and into hole.
- 1.3 Thread cylinder lock nut onto mortise key cylinder. Be sure to fasten down tight.
- 1.4 Position back cover plate.
- 1.5 Install screws. (8-32 x 1/4" undercut flat head socket machine security screw).  
Do not tighten down.

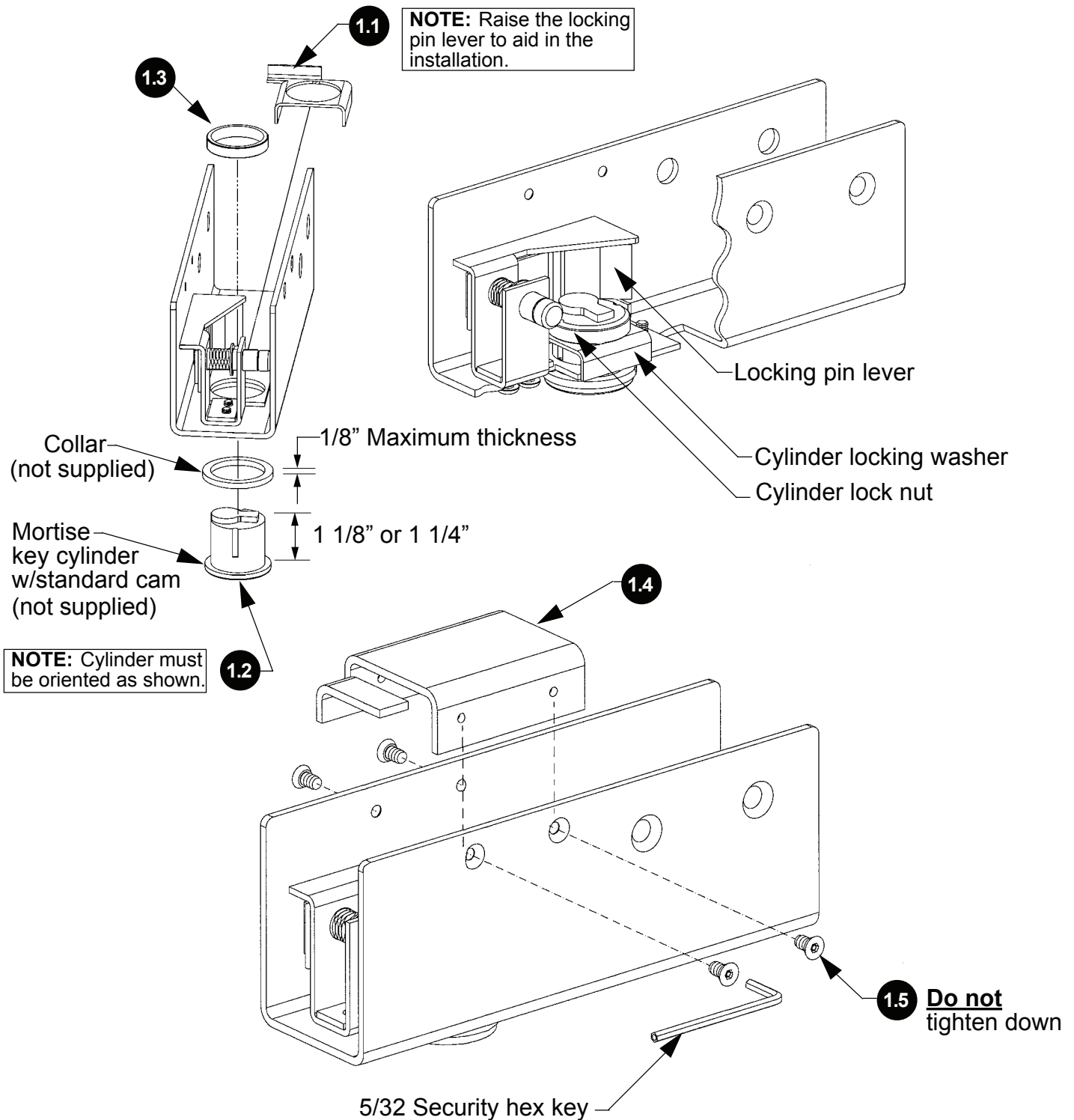

## 2 Adjust and install bottom mullion fitting.

**Note:** If bottom mullion fitting already exists, go to Step 3.

- 2.1 Adjust ball plunger out until ball is compressed when fitting is engaged with mullion. Once adjusted properly, lock-tight in place.
- 2.2 Drill 5/8" diameter x 1 3/4" deep holes.
- 2.3 Install 5/16" x 18 expansion anchors.
- 2.4 Position bottom mullion fitting.
- 2.5 Install screws (5/16 - 18 x 1 3/4" flat Phillips head machine screw).

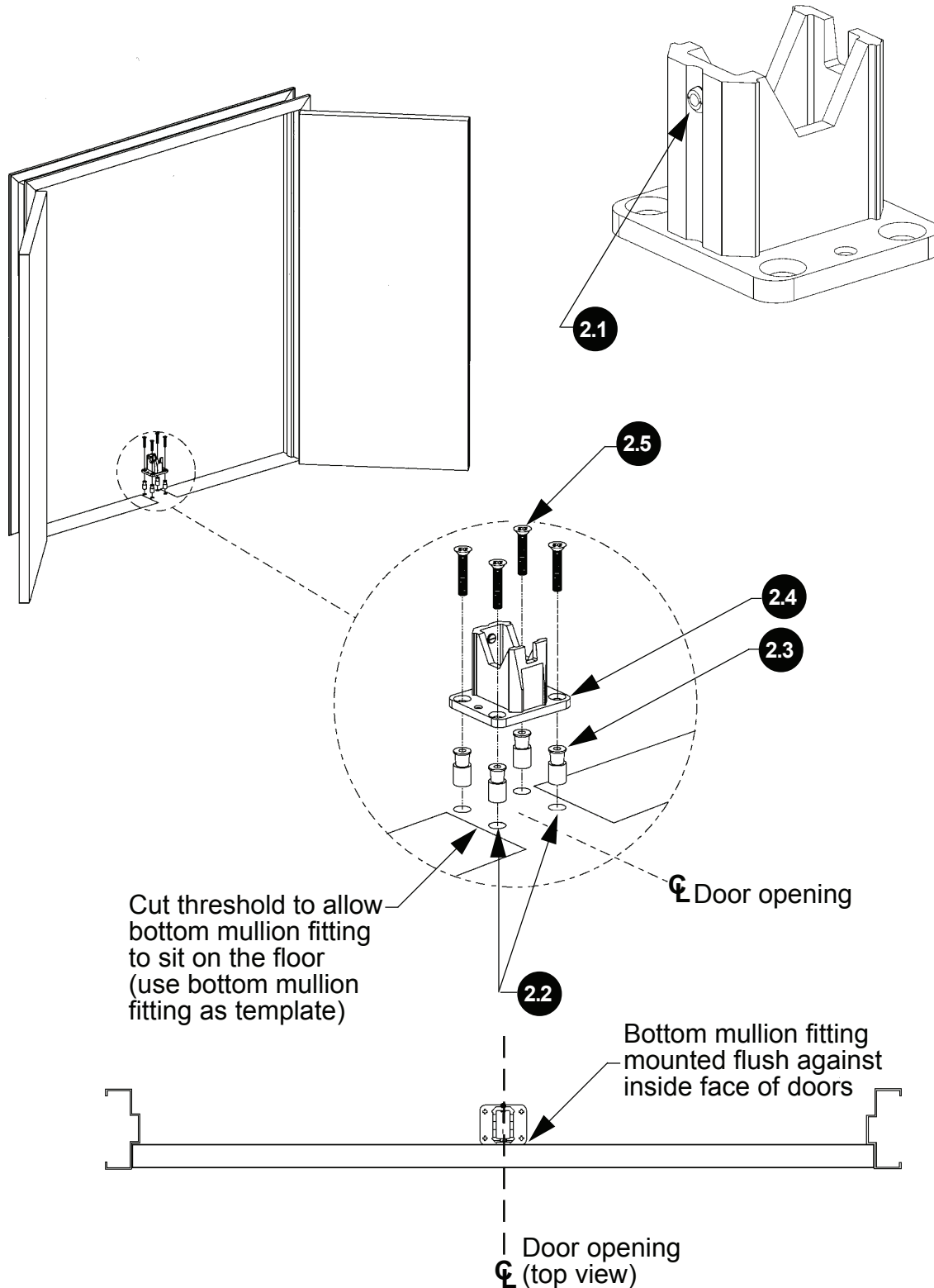

### 3 Size mullion.

- 3.1 Measure distance from frame to bottom mullion fitting.
- 3.2 Determine mullion length using formula and cut. Remove all burrs and sharp edges.

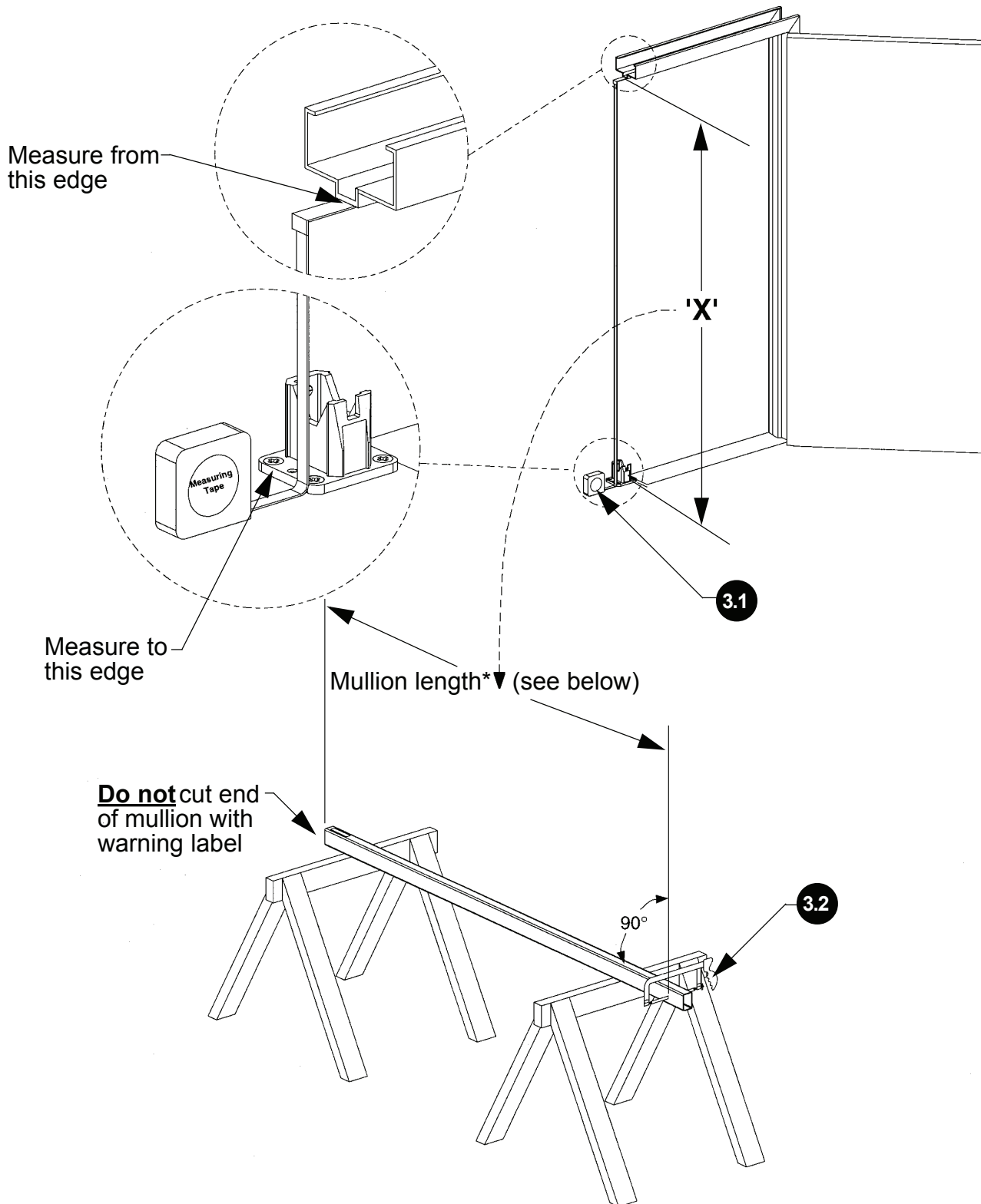

\* Mullion length = 'X' less 5 11/16"  
(for electric KR9854 mullion length = 'X' less 5 3/4")

## 4 Install top mullion fitting.

- 4.1 Position top mullion fitting.
- 4.2 Mark holes.
- 4.3 Drill and tap frame for 5/16 - 18 screws using top mullion fitting as template.
- 4.4 Install screws (5/16 - 18 x 1 1/4" flat Phillips head machine screw).
- 4.5 Position fusible spacer.
- 4.6 Install screws (1/4 - 20 x 3/8" Phillips pan head machine screw).

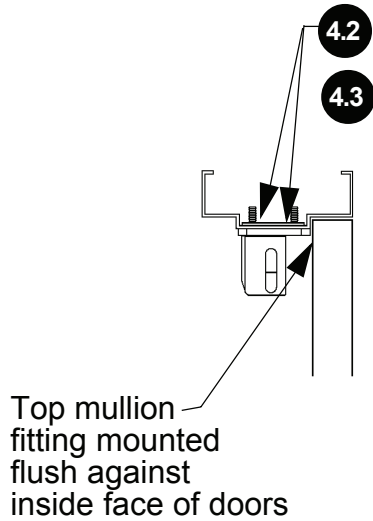

Top mullion fitting shim  
**Note:** If mullion is cut between 1/16" - 1/8" too short, add top mullion fitting shim.

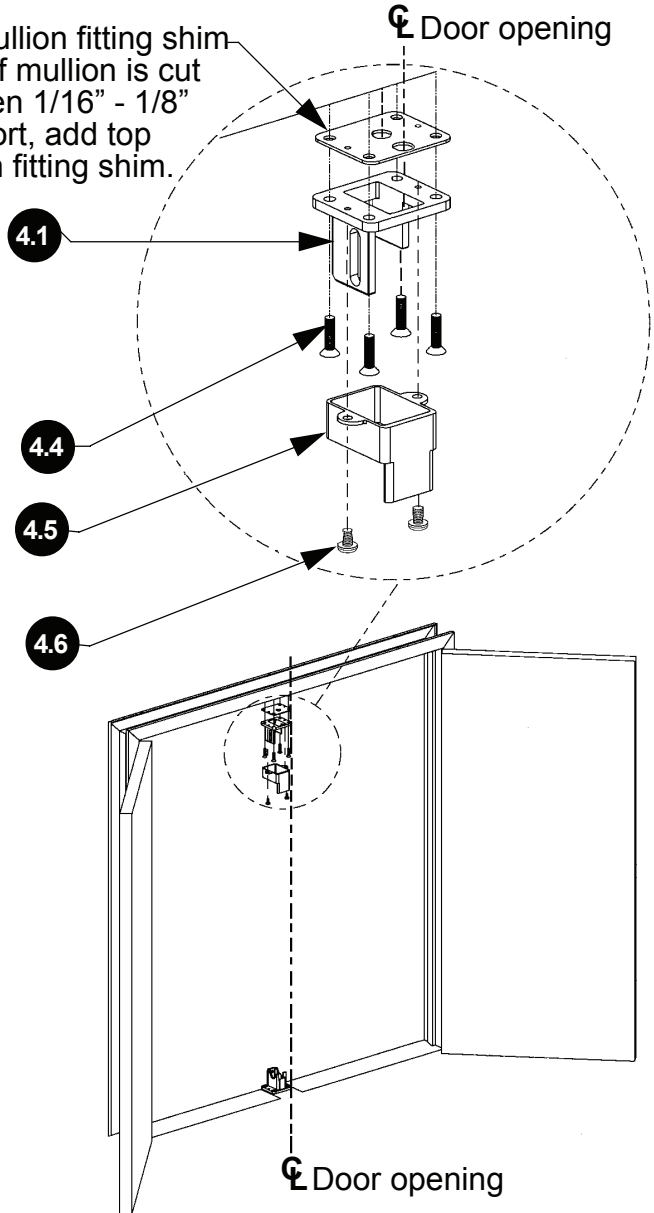

Mounting top mullion fitting on optional frame styles:

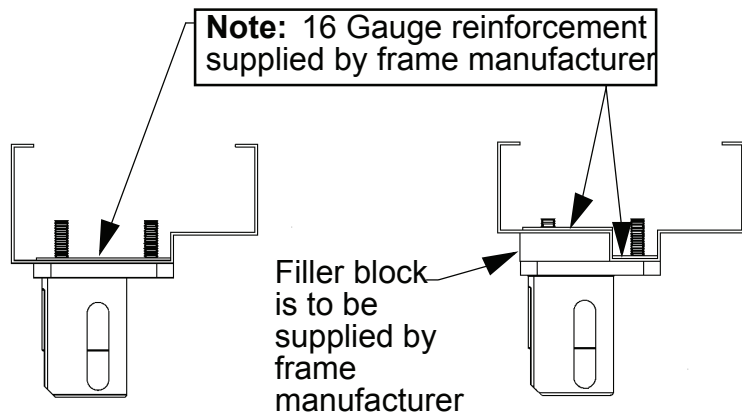

**Note:** KR9854 Electric Mullion installation only.

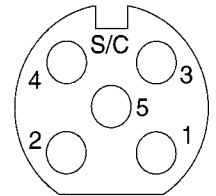
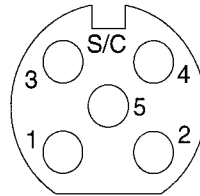
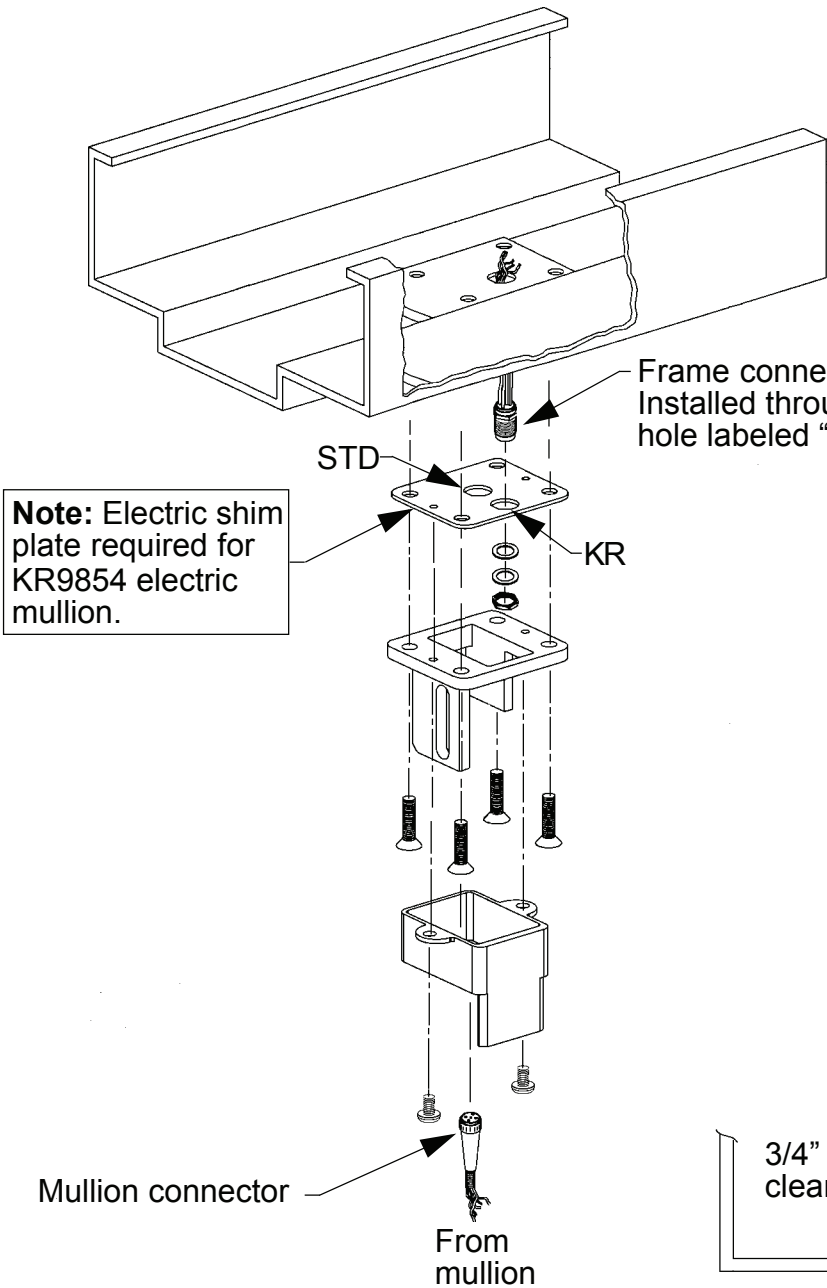

Mullion connector (Viewed from end)      Frame connector (Viewed from end)

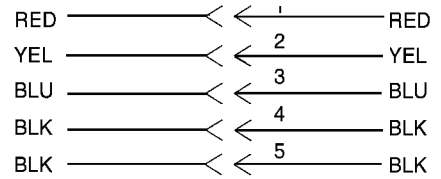

**Wiring diagram**

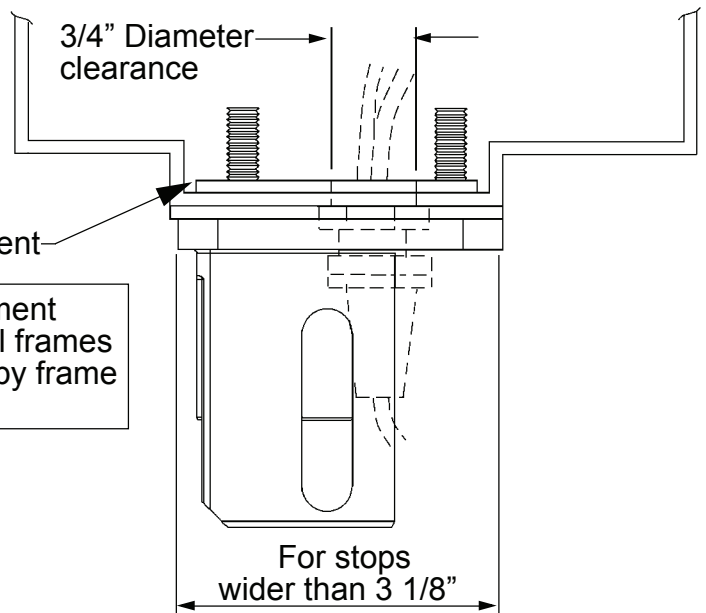



## 5 Attach keyed removable unit to mullion.

- 5.1 Position keyed removable unit onto top of mullion.
- 5.2 With a hammer and a block of wood, tap keyed removable unit snug against mullion.
- 5.3 Drill two 13/32" diameter holes using holes in unit as template.
- 5.4 Drill two) 11/32" diameter holes.
- 5.5 Install sex bolts by tapping into hole with a hammer and a block of wood.
- 5.6 Install screws (1/4 - 20 x 1" flat head socket security machine screw).
- 5.7 Tighten down screws (4 places).

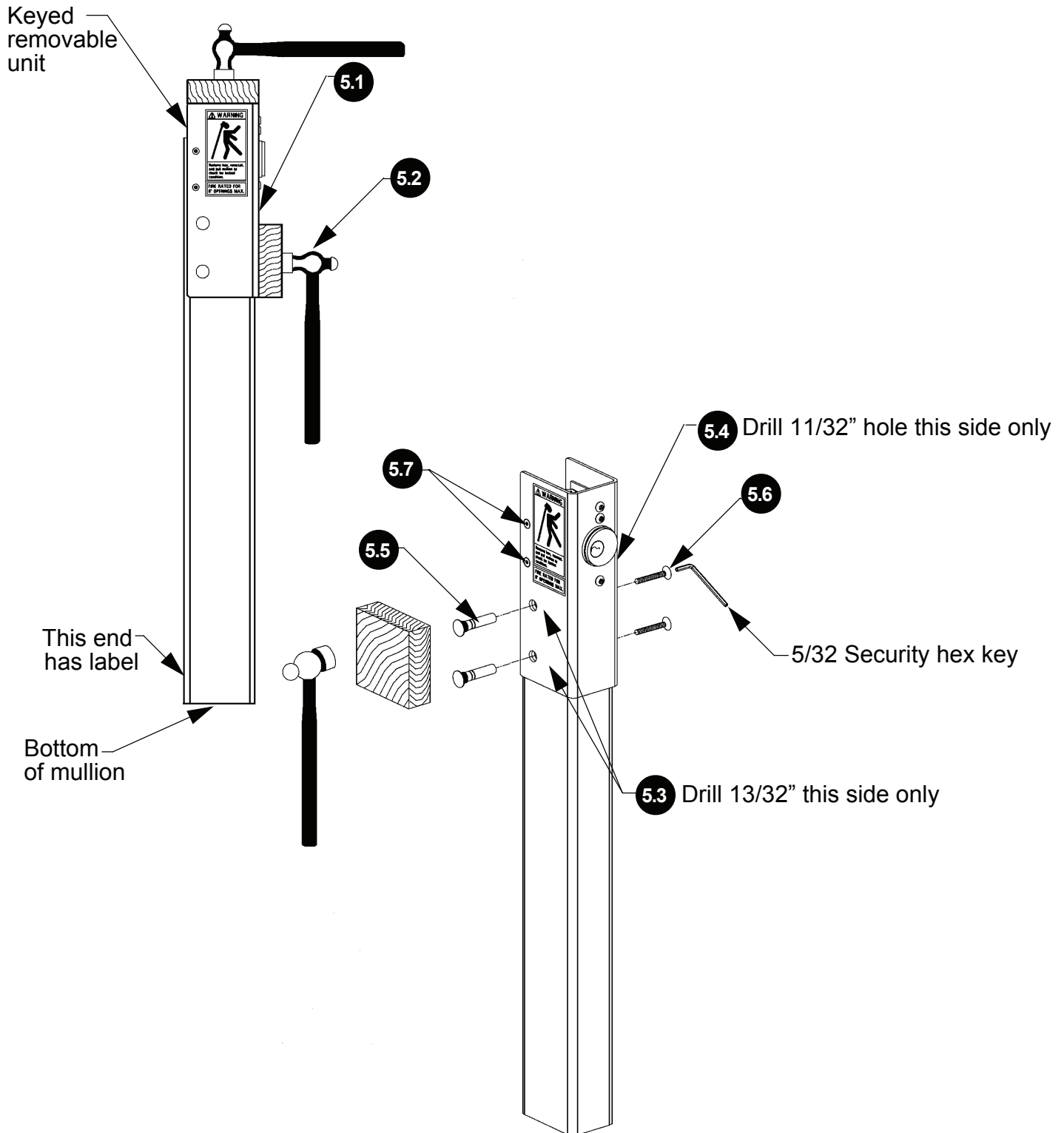

## 6 Final installation and adjustment.

- 6.1 Install screw (8 - 32 x 3/8" set screw) until flush with face of top mullion fitting.
- 6.2 Check for tightness of mullion by pushing and/or pulling on mullion. To tighten, remove mullion (see Step 7) and rotate set screw out 1/2 turn. Repeat this procedure until desired tightness is reached.

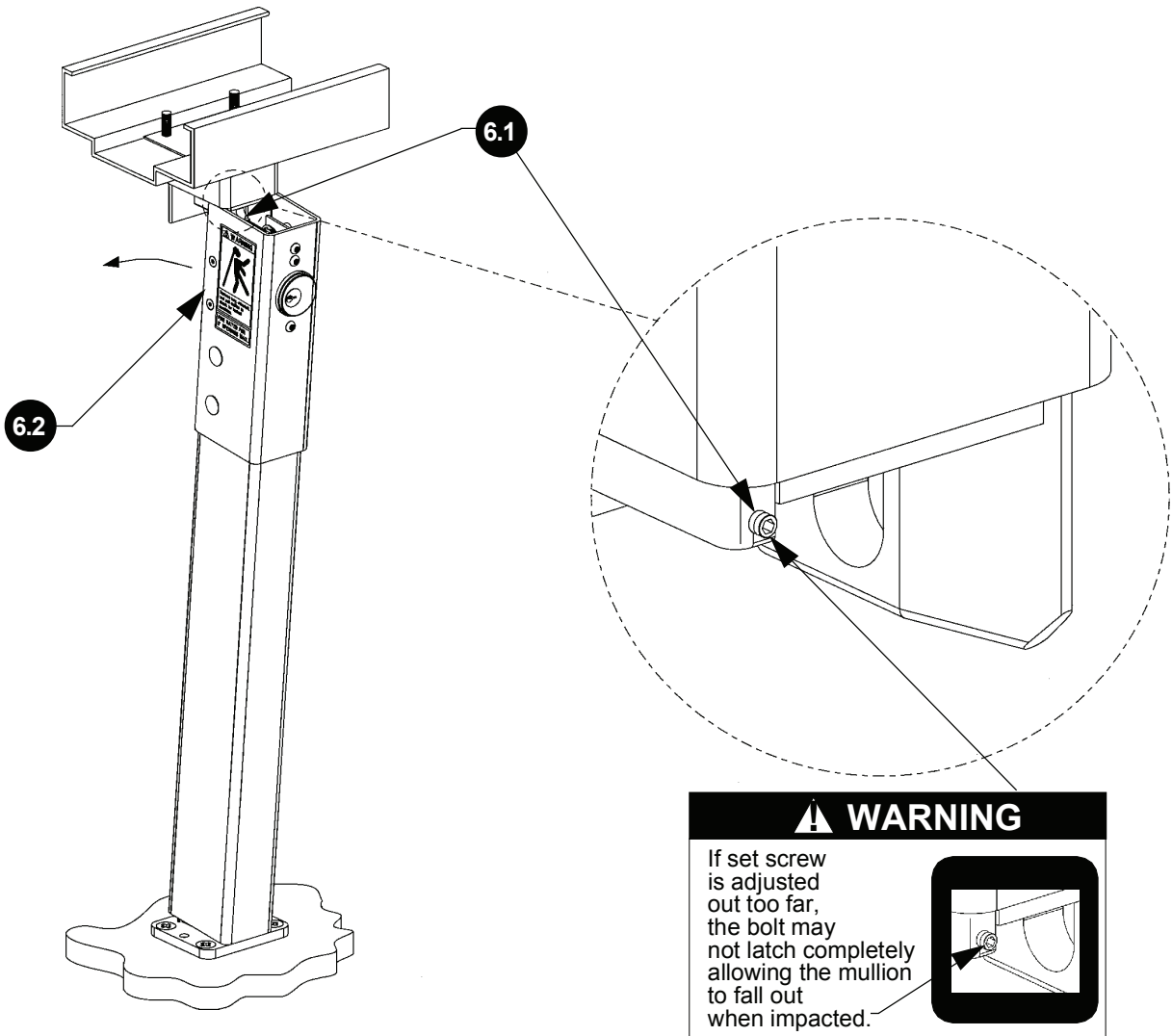

## 7 Operation.

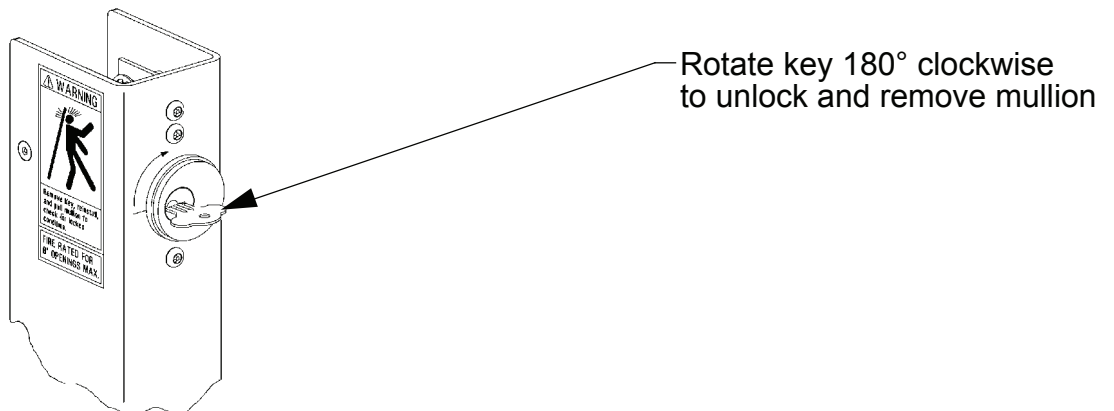

**Customer Service**

1-877-671-7011 [www.allegion.com/us](http://www.allegion.com/us)



© Allegion 2014  
Printed in U.S.A.  
941061-00 Rev. 01/14-b