

6500 PRIVACY LATCH-PUSH SIDE THUMBTURN LOCK

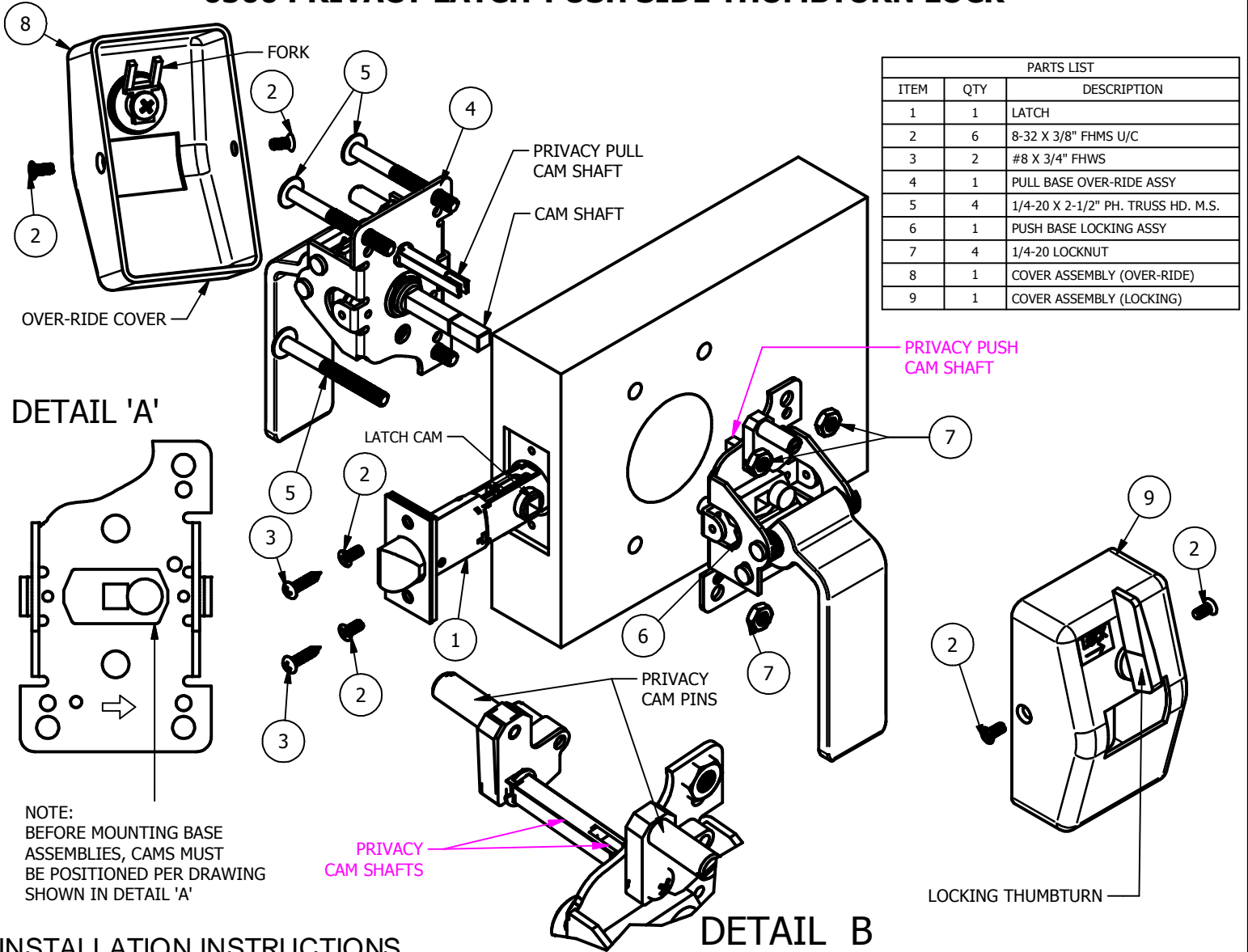

NOTE:
BEFORE MOUNTING BASE
ASSEMBLIES, CAMS MUST
BE POSITIONED PER DRAWING
SHOWN IN DETAIL 'A'

INSTALLATION INSTRUCTIONS

1. Prep door according to latch backset per template.
2. Install latch (Item 1) using either wood or machine screws (Items 2 or 3) depending on door type.
3. Take both base assemblies (Items 4 & 6) and rotate cam pin as shown in Detail "A" above. Place pull base over-ride assembly (Item 4) on pull side of door and slide the cam shaft through the latch cam. Place push base locking assembly (Item 6) on push side of door and engage push cam onto the pull side cam shaft. **Both privacy cam pins must be at the 12 o'clock position in order for the privacy cam shafts to interlock as shown in Detail "B"**. Check that they are interlocked properly by rotating one privacy cam and making sure the other side is rotating at the same time.
4. Fasten both side using (4) 1/4-20 machine screws and lock nuts (Items 5 & 7). Test both handles for free movement of the latch bolt before tightening all screws. If latch bolt does not extend or retract freely because of any type of binding, loosen screws to align adjustment of base assemblies and retighten screws one at a time while checking for proper latch retraction. Mounting hardware (Items 5 & 7) must be tightened before proceeding to next step.
5. Place over-ride cover assembly (Item 8) on the pull side of the door making sure that the forks on the inside of the cover engages the privacy cam and fasten with (2) 8-32 screws (Item 2).
6. Repeat Step 5 with locking cover (Item 9) on the push side of the door.



© www.abhmf.com
E-mail: abhinfo@abhmf.com
Architectural Builders Hardware Mfg., Inc.
1222 Ardmore Ave., Itasca, IL 60143
630.875.9900; FAX 800.9FAXABH (932.9224)

©2012 ABH Mfg., Inc.
printed in USA

6500-1-07.IDW

6500

REVISED 08-08-12

DOOR PREP

1. Install door
2. Locate horizontal centerline on door
3. Verify backset (2-3/4", 3-3/4", 5" or 7"). Tape template to door.

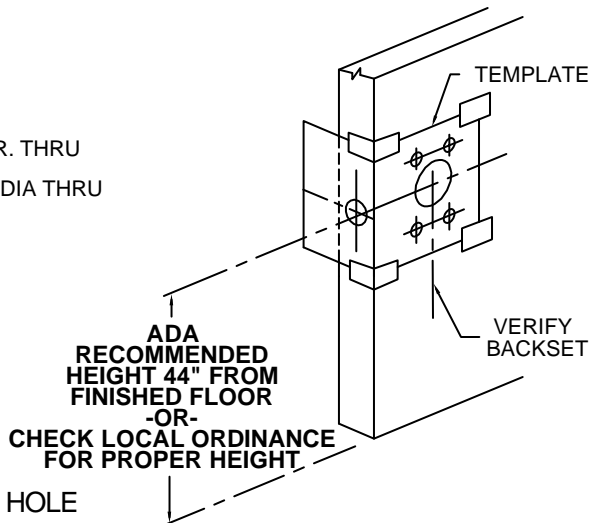
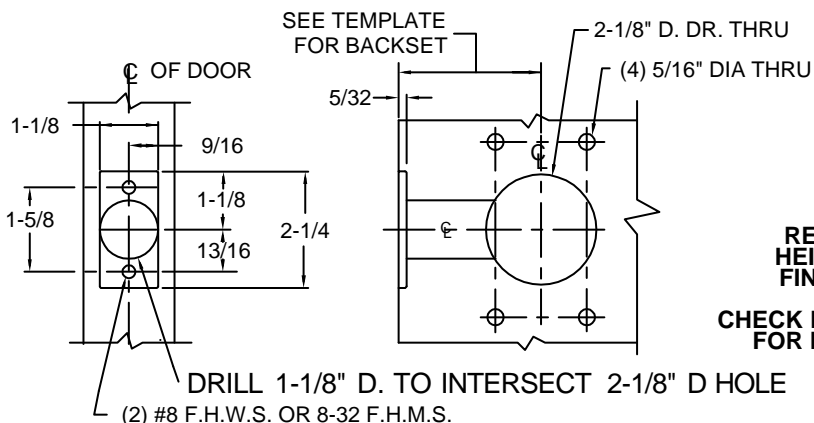

FRAME PREP

1. Mark centerline of latch bolt on frame
2. Center strike and mark screw positions
3. Mortise to required strike and box depth

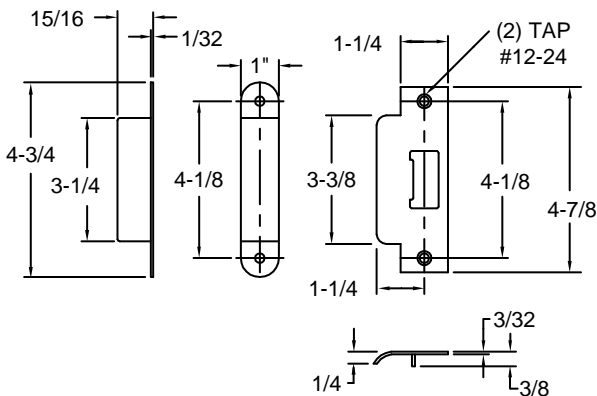

ASA STRIKE & BOX

ALL DIMENSIONS IN INCHES

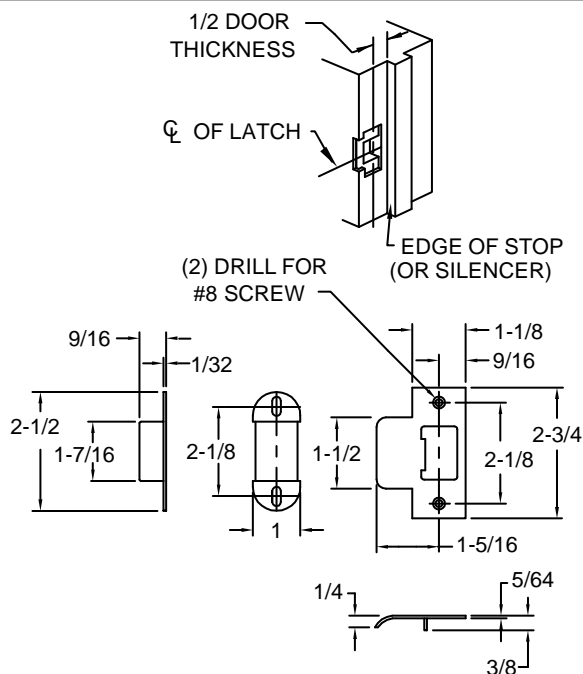

STANDARD STRIKE & BOX

LATCH/HANDLE ASSEMBLY

1. Install latch bolt.
Radius portion of latch bolt must face push side of door.
2. Install pull side handle assembly down * with latch shaft thru latch bolt assembly.
3. Mount push side handle down * and install (4) 1/4-20x2-1/2" screws with nuts.
4. Mount Cover.

* CAM PIN MUST BE ROTATED TOWARD SIDE INDICATED BY ARROW STAMPED ON BASE SEE DRAWING ON FRONT OF TEMPLATE

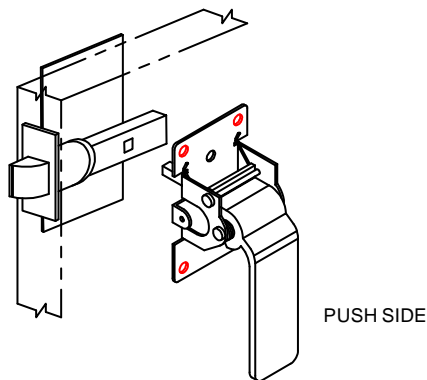

® www.abhmfg.com

E-mail: abhinfo@abhmfg.com

Architectural Builders Hardware Mfg., Inc.

1222 Ardmore Ave., Itasca, IL 60143

630.875.9900; FAX 800.9FAXABH (932.9224)

© 2009 ABH Mfg., Inc.
printed in USA

6500-2-07.DWG

6500

REVISED 08-08-12

6500 SERIES PRIVACY HOSPITAL
PUSH/PULL LATCH DOOR PREP INFORMATION FOR
VERTICAL MOUNT

DO NOT COPY AND USE THIS AS A TEMPLATE
PLEASE CALL FACTORY FOR FULL SCALE TEMPLATE

DOOR PREP INFORMATION:

1. BACKSET DIMENSION FROM LOW EDGE OF BEVEL.
2. CENTER PUNCH ALL HOLES.
3. DRILL HOLES (FOR HOLLOW METAL DOORS, DO NOT DRILL THRU. CENTER PUNCH & DRILL HOLES FROM BOTH SIDES OF DOOR).

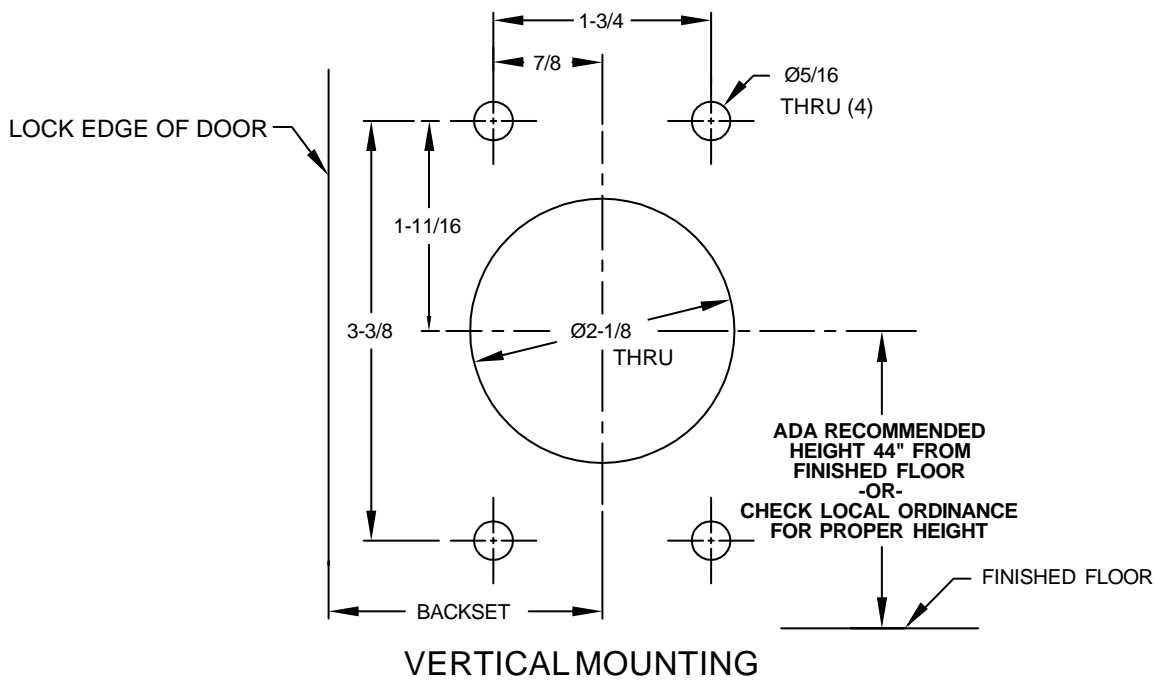

® www.abhmfg.com

E-mail: abhinfo@abhmfg.com
Architectural Builders Hardware Mfg., Inc.
1222 Ardmore Ave., Itasca, IL 60143
630.875.9900; FAX 800.9FAXABH (932.9224)

© 2012 ABH Mfg., Inc.
printed in USA

6500-3-07.DWG

6500

REVISED 08-08-12