

Hi/Shear® Magnetic Locks

The SDC Hi/Shear® is a totally concealed, high security, failsafe locking mechanism with superior appearance. The patented Hi/Shear® electromagnetic lock design incorporates a “floating” armature assembly and special alloy steel locking “tabs” on both the lock and armature assemblies, that may be adjusted both vertically and laterally to compensate for wide door gaps and warped or misaligned doors. Hi/Shear® magnetic locks are ideal for use on commercial grade hollow metal and wood doors and metal frames and Herculite doors with top rails.

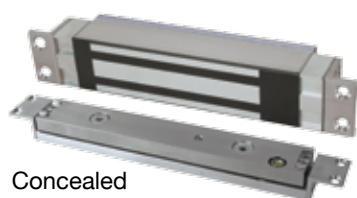

Concealed

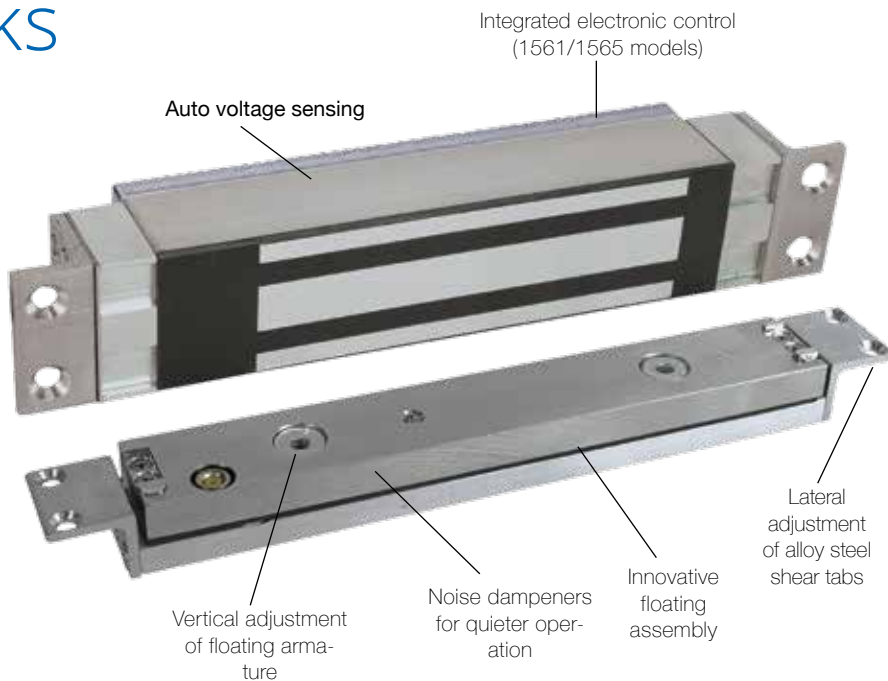

Semi-Concealed



Surface Mount

FEATURES

DOOR STATIC AND ALIGNMENT SENSOR

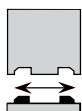

The door static sensor ensures that the door is at rest and aligned, before the magnet is permitted to energize, eliminating potential for lock misalignment.

LATERAL ALIGNMENT ADJUSTMENT

Lateral adjustment of shear tabs to compensate for warped or misaligned doors, permitting accurate locking.

VERTICAL ALIGNMENT ADJUSTMENT

Vertical adjustment of the armature compensates for wide door gaps.

“FLOATING” ASSEMBLY

A unique “floating” action makes for easier armature lift when the magnet is energized and provides the ability to overcome wide door gaps.

2000 OR 2700 LBS HOLDING FORCE

2000 or 2700lbs. of holding force without current inrush or high operating temperature normally associated with shear locks.

ALLOY STEEL SHEAR “TABS” ON LOCK AND ARMATURE

Alloy shear tabs are used on both the lock and the armature to ensure continued high holding force. There is no profiling of the soft armature steel that may be prone to wear and reduced holding force.

ADVANCED ELECTRONIC CIRCUITRY

Advanced electronic circuitry that incorporates door static, positioning and timed relock sensor and automatic voltage sensing for 12/24VDC input.

QUIETER OPERATION

Noise dampeners greatly reduce the noise associated with locking and unlocking of other shear locks on the market.



CONCEALED HI/SHEAR®

The concealed configuration the innovative Hi/Shear® concealed electro-magnetic lock is available with 2000 lbs and 2700 lbs holding force for standard 1-3/4 to 2" frames with internal electronics, as well as narrow 1-1/4 to 1-1/2" frames with external electronics.

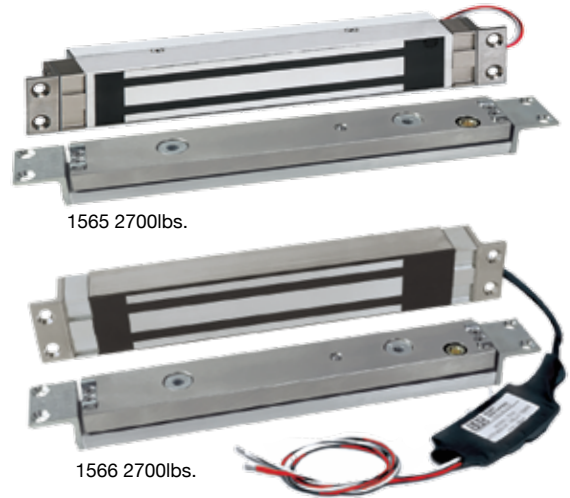
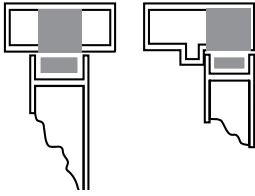

MODELS

2000 LBS HOLDING FORCE, 8" X 1-1/2" LOCK

1561 Integrated electronics, 1-5/8" depth for 1-3/4" to 2" frames



1562 External electronics, 1-1/4" depth for 1-1/4" to 1-1/2" frames



2700 LBS HOLDING FORCE, 10-7/16" X 1-1/2" LOCK

1565 Integrated electronics, 1-5/8" depth for 1-3/4" to 2" frames



1566 External electronics, 1-1/4" depth for 1-1/4" to 1-1/2" frames

SEMI-CONCEALED HI/SHEAR®

The semi-concealed configuration incorporates the innovative 2000 lb Hi/Shear® concealed electromagnetic lock with a surface mounted armature assembly. The semi-concealed design also provides the advantage of mounting the Hi/Shear® on the secure side of the door opening, eliminating potential for tampering.



MODELS

1562SC

Semi-concealed mounted to the push side of an out-swing door. The mortise magnet is concealed in the frame and the armature is surface mounted on the door. For metal door and frame, glass door with top rail and metal frame, or wood door and metal frame.

1562SCHDB1/2

Semi-concealed mounted to the push side of an out-swing glass door. The mortise magnet is concealed in the frame and the armature is surface mounted on the 1/2" glass door where no top rail is present utilizing the Herculite door bracket.

1562SCHDB3/4

Semi-concealed mounted to the push side of an out-swing glass door. The mortise magnet is concealed in the frame and the armature is surface mounted on the 3/4" glass door where no top rail is present utilizing the Herculite door bracket.

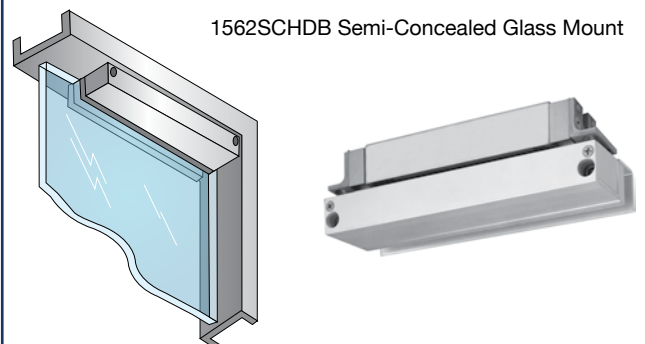
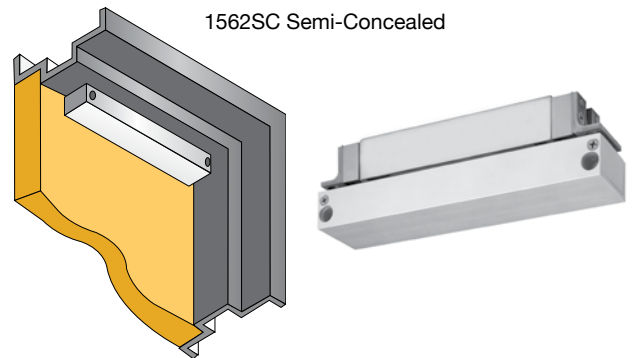

SURFACE MOUNT HI/SHEAR®

MODELS

1561S Surface mounted to the push side of an out-swing door. For metal door and frame, glass door with top rail and metal frame, or wood door and frame

1561TJ Surface mounted to the pull side of an in-swing door. For metal door and frame, glass door with top rail and metal frame, or wood door and frame. This mounting configuration eliminates the need for cumbersome and unsightly top jamb Z brackets normally associated with pull side mounted of magnetic locks

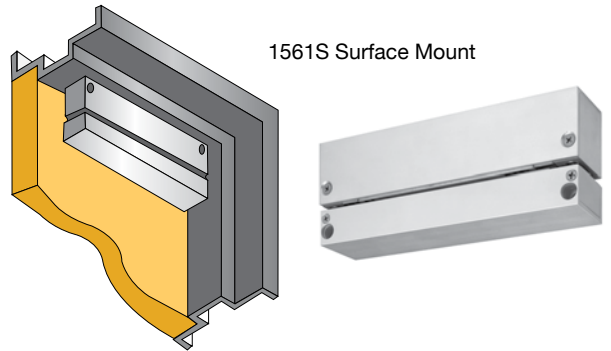

1561S Surface Mount

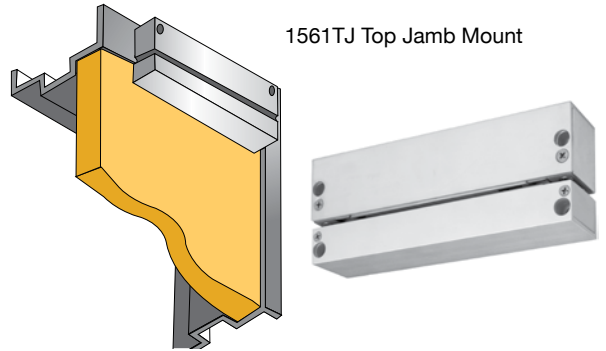

1561TJ Top Jamb Mount

SPECIFICATIONS

Automatic Voltage Sensing Input

1561/1562 650/350mA @ 12/24VDC

1565/1566 800/400mA @ 12/24VDC

Lock Body Dimensions

1561 8"L x 1-1/2"W x 1-5/8"D

1562 8"L x 1-1/2"W x 1-1/4"D

1565 10-7/16"L x 1-1/2"W x 1-5/8"D

1566 10-7/16"L x 1-1/2"W x 1-1/4"D

Armature Assembly Dimensions

1561/1562 8"L x 1-1/2"W x 7/8"D

1565/1566 11"L x 1-1/2"W x 7/8"D

ARMATURE AVAILABLE

MODELS

ITC
ITCM Standard mounting armature kit for aluminum and hollow metal doors with 7/8" to 1 1/8" deep top channels, wood doors and factory prepared hollow metal flush edge doors.

FTC
FTCM Mounting kit for field prepared horizontal mounting in hollow metal doors with flush edge.

HTC
HTCM Mounting kit for 1-15/16" deep Herculite channels (add'l charge applies)

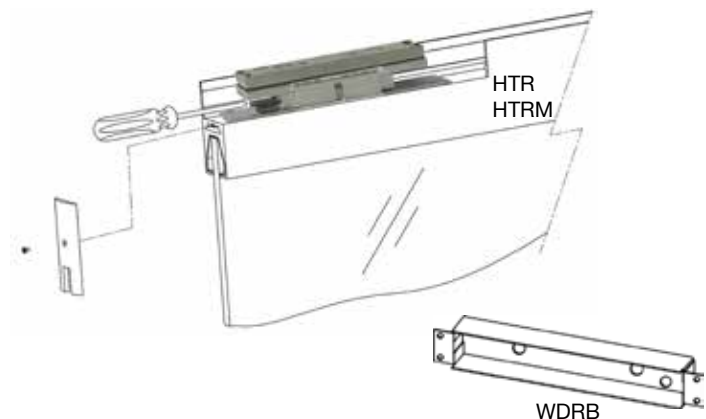



HOW TO ORDER

1 | SPECIFY MODEL

- 1561** Hi/SHEAR® 2000 lb holding force, integrated electronics
- 1562** Hi/SHEAR® 2000 lb holding force, external electronics
- 1565** Hi/SHEAR® 2700 lb holding force, integrated electronics
- 1566** Hi/SHEAR® 2700 lb holding force, external electronics

2 | SPECIFY ARMATURE

Armature supplied with lock. Specify type required:

1565/1566 ITC, FTC or HTC

1561/1562 ITCM, FTCM or HTC M

ITC
ITCM Standard mounting armature kit for aluminum and hollow metal doors with 7/8" to 1 1/8" deep top channels, wood doors and factory prepared hollow metal flush edge doors.

FTC
FTCM Mounting kit for field prepared horizontal mounting in hollow metal doors with flush edge.

HTC
HTCM Mounting kit for 1-15/16" deep Herculite channels (add'l charge applies)

3 | SPECIFY OPTIONS

- B** **Bond sensor** indicates proper armature contact or reduced holding power due to improper armature contact or tampering. SPDT 0.25Amp (not available on **1562/1566**)
- D** **Door position switch** indicates door open or closed. SPDT 0.25 Amp maximum.
- L3** **External LED status indicator**, mounts separately through the frame and may be used to indicate lock is energized or wired to BAS bond sensor for door status.
- HTR** Herculite top rail armature adjustment bracket for **1565** and **1566**
- HTRM** Herculite top rail armature adjustment bracket for **1561** and **1562**
- WDRB** Wood door reinforcement box for **1565** and **1566**
- WDRBM** Wood door reinforcement box for **1561** and **1562**