

Installation Instructions



ML2000 Mortise Locks with MUSÈO Levers Template T31046 Sectional Trim

In Canada: ASSA ABLOY DSS Canada
160 Four Valley Drive
Vaughan, ON, L4K 4T9
www.assaabloycanadads.ca

In U.S.: Corbin Russwin, Inc.
225 Episcopal Road
Berlin, CT 06037-4004
www.corbinrusswin.com

FM274 05/07 (617417705)

Technical Product Support:
Phone: 888-607-5703 Fax: 800-659-7293

MUSÈO Collection Sectional Trim

CAUTION
DOOR MUST REMAIN OPEN
DURING INSTALLATION.
USE DOOR STOP.

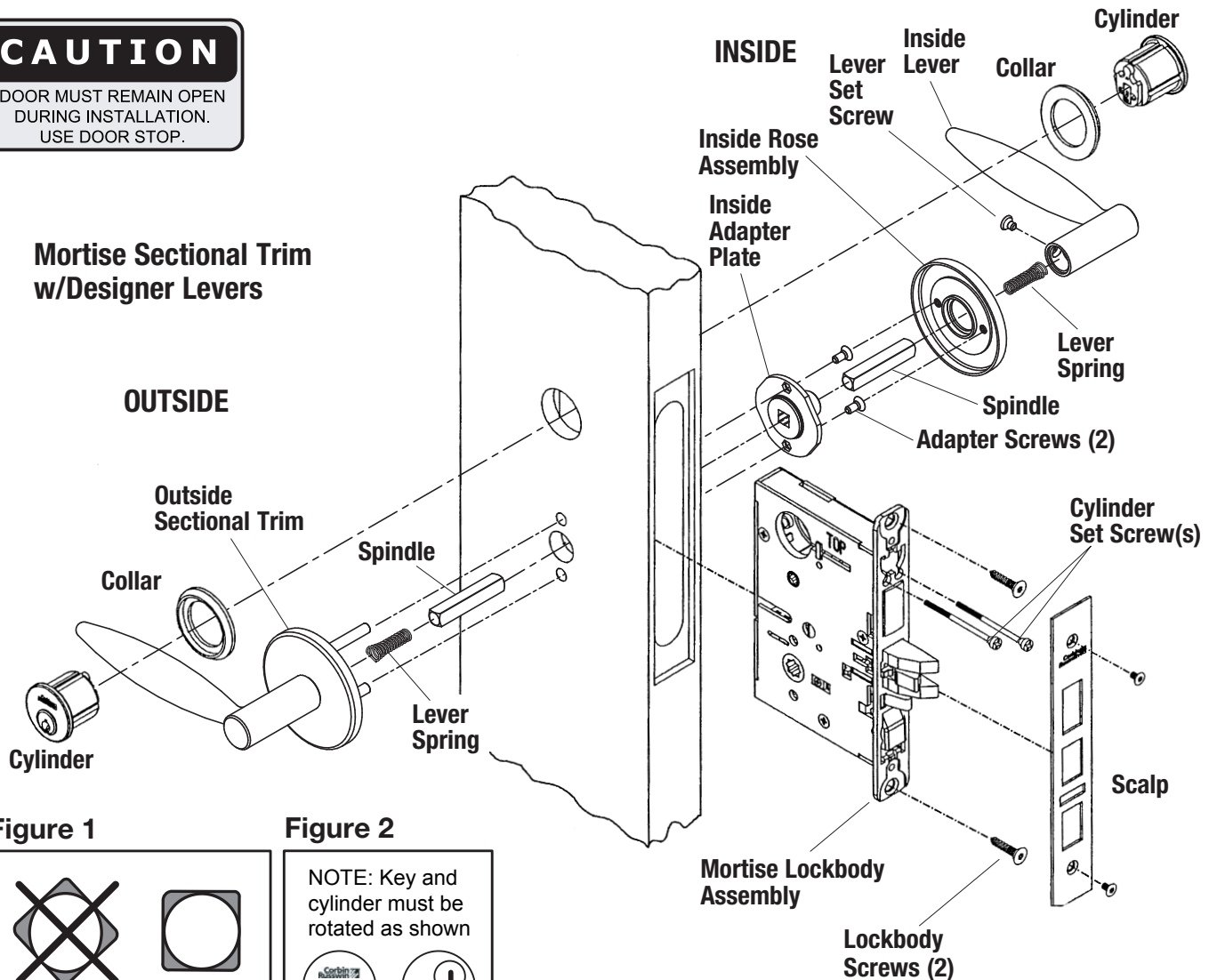

Figure 1

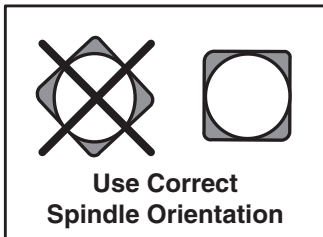
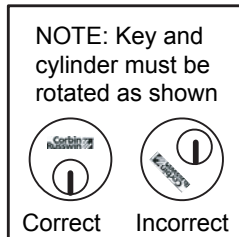

Figure 2



Step 1

Mortise door pocket for lock assembly and bore holes, using template listed or door marker provided. Thread cylinder set screws partially into lock before inserting lock into mortise. Insert lock into mortise opening.

Hand Tighten Lockbody Screws

Step 2

Install spindle from each side with proper orientation. (See Figure 1)

Step 3

Install lever spring in inside and outside lever.

Step 4

Install outside lever and rose trim assembly. Be sure levers are properly positioned.

If needed, rotate adapter bushing to insure horizontal lever position and maximum thread engagement between lever and adapter bushing.

Step 5

Slide inside adapter plate assembly over spindle and secure with the two adapter plate screws, ensuring the lever set screw threaded hole in the adapter plate assembly is in the proper position to accept the lever set screw when the lever is attached.

Step 6

Install inside rose assembly.

Step 7

Install inside lever and secure with lever set screw.

Step 8

Install collar and cylinder for outside and inside, if applicable. Screw cylinders flush to escutcheon or collar with Corbin Russwin logo on top (see Figure 2). Secure cylinder with cylinder set screw(s).

Step 9

Check function of lock from both sides using key and levers.

Step 10

Tighten screws on mortise lock.

Step 11

Install scalp.

Check function of lock from both sides using key and levers.

CAUTION: With door closed, VERIFY latch bolt and deadbolt will project into strike opening FREELY.