

Installation Instructions ML01/ML03/ML04/ML05

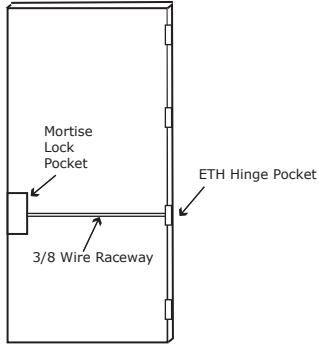

Corbin Russwin Lock modified by Command Access Technologies

STEP 1: The door must be machined with a 3/8" wire raceway, mortise lock pocket & prepped for a energy transfer hinge. **Make sure the mortise pocket is free of debris.**



STEP 2: Run the wires from the ETH hinge through the 3/8" raceway starting at the ETH hinge & exiting into the mortise pocket.

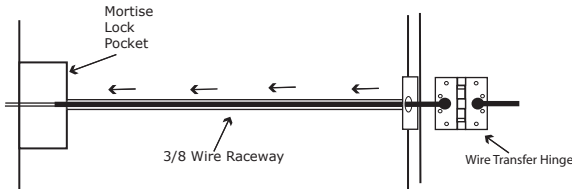

STEP 3: Screw the ETH hinge to the door. At this time **DO NOT** connect the hinge wires on the jamb side to the wires coming from the power supply.

STEP 4: Connect the wires exiting the mortise pocket to the Bridge Rectifier (included).

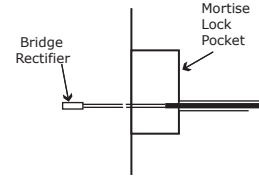

STEP 5: Connect the Bridge Rectifier to the plug exiting the mortise chassis.

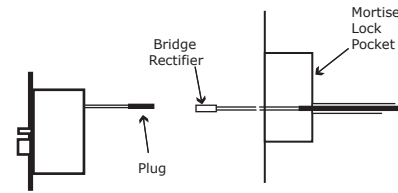

STEP 6: Carefully slip the connected mortise lock chassis into the mortise pocket paying close attention not to pinch any wires.

STEP 7: Mount the chassis per manufacturer's instructions.

STEP 8: Connect the wires from the power supply at the ETH hinge on the jamb side. Connect the hinge to the jamb.

LEGEND OF TERMS

EU: (Fail Secure) When power is applied, the outside trim will unlock. When power is removed, the outside trim is locked.

EL: (Fail Safe) When power is applied, the outside trim will lock. When power is removed, the outside trim is unlocked.

REX: (Request to Exit Switch) Monitors the inside handle.

DPS: (Door Position Switch) Monitors the door position via the anti pick (Deadlatch).

LBM: (Latchbolt Monitor Switch) Monitors the position of latchbolt.

ELECTRICAL SPECIFICATIONS

SOLENOIDS:

| VOLTS | CURRENT | COIL RESISTANCE |
|----------|---------|-----------------|
| 24VAC/DC | 350mA | 69 Ohms +/- 10% |
| 12VAC/DC | 700mA | 18 Ohms +/- 10% |

SWITCHES: 5A 124VAC/DC

REX: Green - Common (C)
Blue - Normally Open (NO)
Gray - Normally Closed (NC)

LBM: Green/Black - Common (C)
Blue/Black - Normally Open (NO)
Gray/Black - Normally Closed (NC)

DPS: Green/Red - Common (C)
Blue/Red - Normally Open (NO)
Gray/Red - Normally Closed (NC)

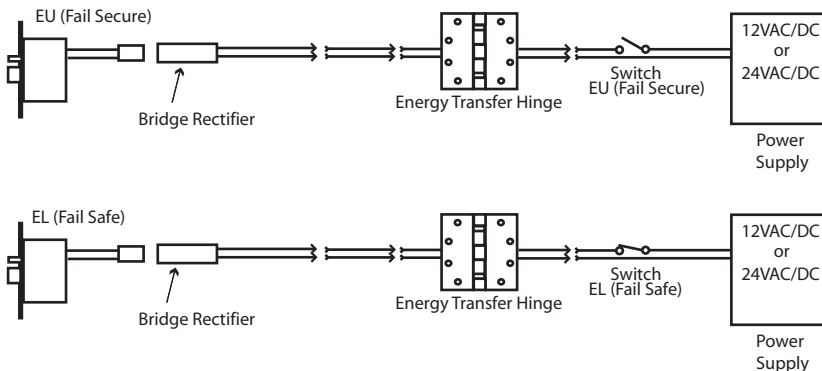

Handing Instructions for ML01/ML03/ML04/ML05 Mortise Locks

- STEP 1:** Move the RED Locking Screw to side of lock-body being locked.
- STEP 2:** Push in latch then depress catch plate with screw driver.
- STEP 3:** Pull latch out of lock-body and rotate 180°.

- STEP 4:** Push in latch while holding screw driver behind latch tail. Note: Push in latch until catch plate is no longer depressed.
- STEP 5:** Rotate lock front to match level of door.

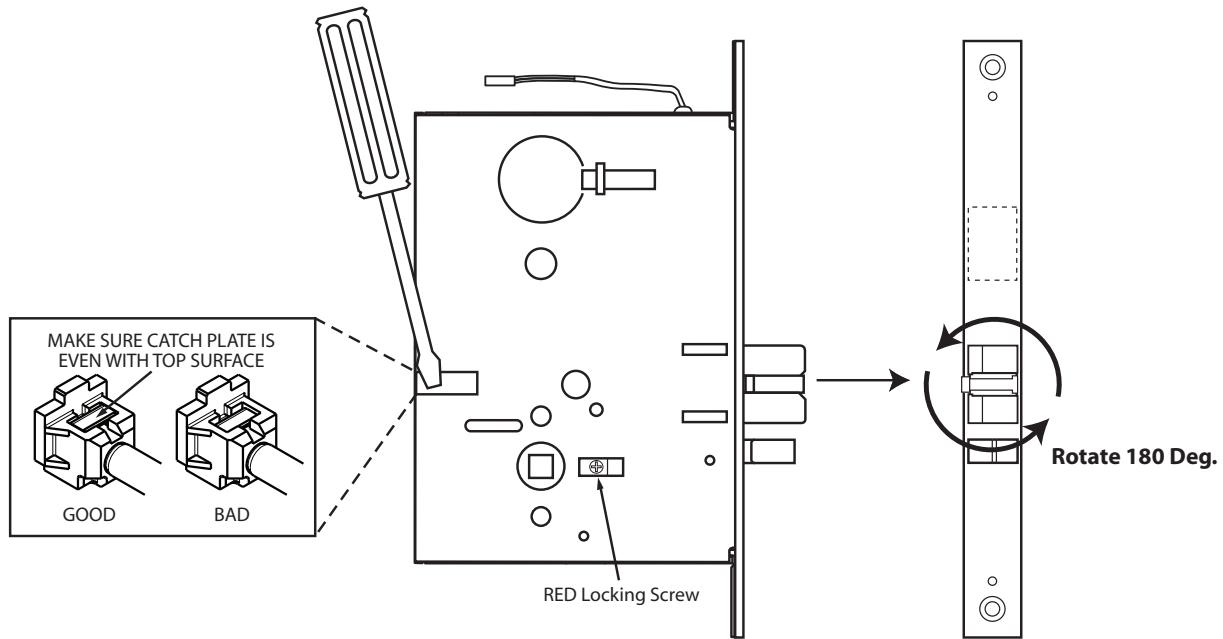

Template for ML01/ML03/ML04/ML05 Mortise Locks

