

SAFETY INSTRUCTIONS

This device is limited in its applications, interface only with components that are equally rated to this device. Failure to observe and adhere to operating limits detailed in these instructions void its warranty and Adams Rites responsibility. Care must be taken to ensure no shorts are across power feed wires to power transfer and electric latch dogging exit device.

FUNCTION

This ED feature is available on all 3000/8000 series exit devices and provides for electrical dogging of the device. To engage the electrical dogging, the device pushbar must be manually depressed once power has been applied. The exit device is fail secure. In the event of a power failure, the exit device defaults to the locked position. The device is rated for both continuous and intermittent operation.

SOLENOID SPECIFICATIONS

VOLTAGE	24 VDC CONT. DUTY
CURRENT	.6 AMPS HOLD
COIL RESISTANCE	40 OHMS

MOUNTING INFORMATION

This device is mounted in the standard manner per the specific exit device installation instructions. Ensure that the device functions mechanically prior to operating electrically.

A 3/8" diameter hole on the door must be drilled at the time of installation for wiring access. Refer to fig. 2. The wire must be protected from abrasion where they pass through the hole in the door. A rubber grommet (not supplied) is sufficient.

"PRODUCT MUST BE INSTALLED ACCORDING TO ALL APPLICABLE BUILDING AND LIFE SAFETY CODES"

INSTALLATION HOOKUP

Verify that the power being supplied matches the electrical requirement of each device. Refer to fig. 1 for recommended circuit hookup.

To control the electrical operation, a maintained remote switch is needed to keep the device the electrically dogged. Ensure the switch contacts are rated for the power requirements of the solenoid. Operation of the switch contacts are rated for the power requirements of the solenoid. Operation of the switch will retract the latching mechanism for as long as the switch closure is maintained.

Installation on fire doors requires that this device is under the control of an Automatic Fire Control Alarm System.

To protect switch or relay from arcing due to inductive discharge of the magnet, use a 1N4004 diode or metal oxide varistor (MOV) wired in parallel with the load.

A maximum of 2 electrified devices can be operated with one 4605 Transformer/4603 Rectifier combination.

ELECTRICAL DOGGING MONITORING SWITCH

MONITORING IS AVAILABLE WITH THIS DEVICE. SEE FIGURE 3.

CONTROL SWITCH (N.O.) (EX. TOGGLE SWITCH OR TIMER WITH MAINTAINED CONTACTS)

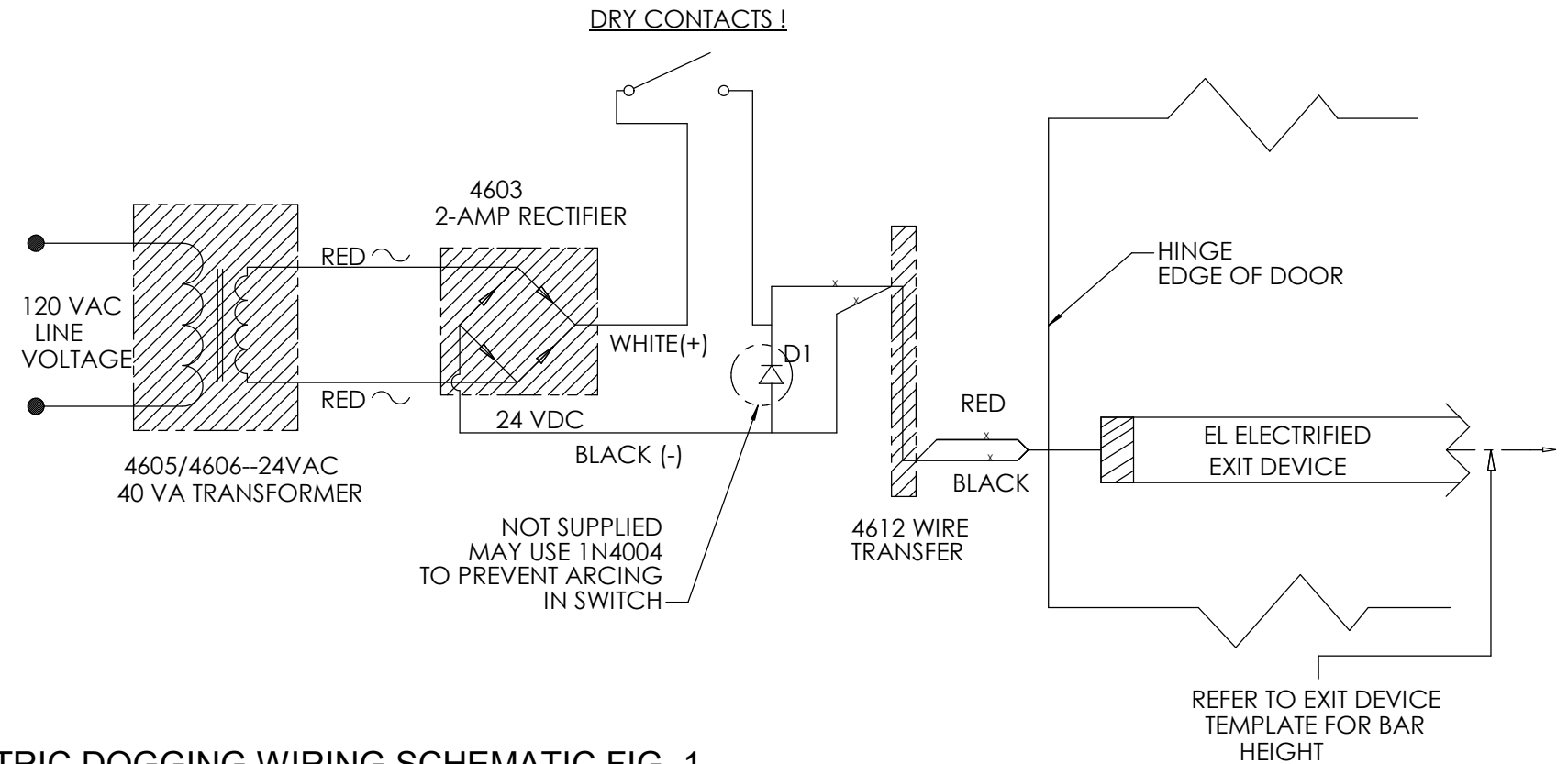

ELECTRIC DOGGING WIRING SCHEMATIC FIG. 1

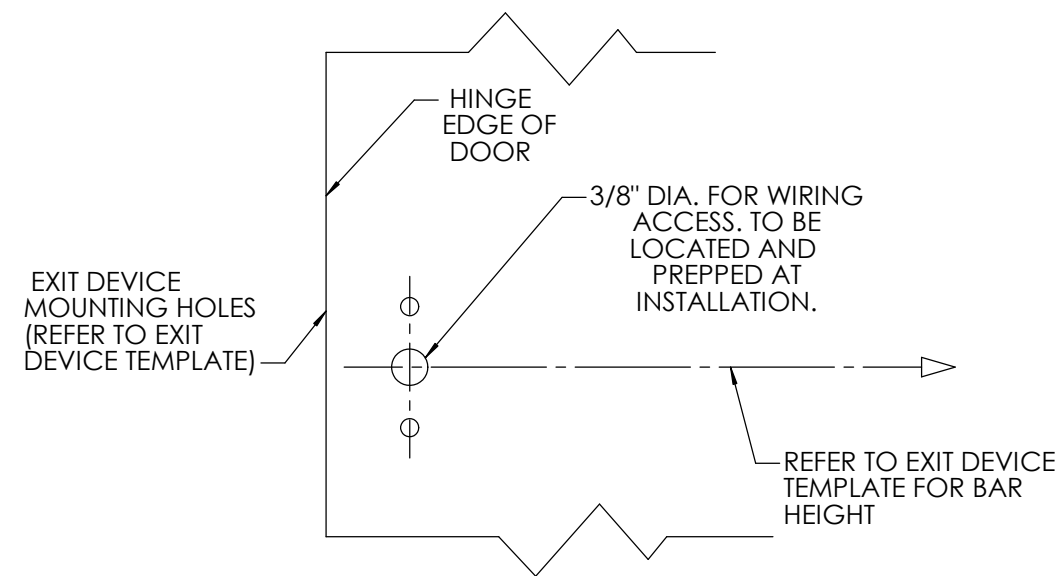

DOOR PREPARATION FIG. 2

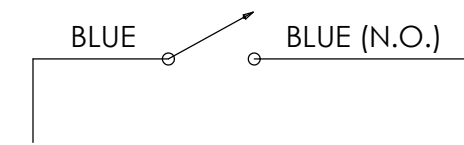

LATCH MONITOR SWITCH

A single pole single throw monitor switch is added to the holding magnet to indicate when the unit is unlatched and electrically dogged. Switch outputs can be used to signal automatic door operators, monitor panels, fire control panels etc.

FIG. 3