



# Sentinel-Prox KP-6840 Reader with Keypad

## Reader Description

## Revision E

July 12, 2006

The Sentinel-Prox KP-6840 Reader is a radio-frequency proximity reader with integrated keypad for Access Control Systems. The Reader consists of a 12-key keypad, transmit/receive antenna, and reader electronics, in a polycarbonate housing. The reader electronics are potted with epoxy resin to protect against the environment. The KP-6840 Reader may be mounted like a cover plate on a single-gang electrical utility box, or on any surface (wall, cabinet, etc).

## Parts List

(a)	Installation Sheet, P/N 005-98-A	Qty=1
(b)	Sentinel-Prox KP-6840 Reader, P/N 005-20-A	Qty=1
(c)	#6-32 x 1" machine screw, P/N 0616MPP	Qty=2

## Installation Procedure

1. Install a single-gang electrical utility box, or drill two no. 27 (0.144 inch) clearance holes for the reader screws and one hole for the cable, at the desired location. Observe ADA height requirements.
2. Snap open the reader's top cover by inserting a wide screwdriver blade into the slot at the bottom edge of the cover, then twisting the blade gently (see Figure 1). **Do not remove** the keypad from the reader.
3. Clip off the white inline connector from the end of the reader's cable. Keep the wires as long as possible.
4. Connect the reader's cable to the access control panel as shown in Figure 2. Connect the **yellow** wire only if used for Beeper control by the panel. In steps 9 and 10, let the yellow wire **float**. Connect the **blue** wire only if used for Hold control by the panel. **Do not connect** the **orange** and **violet** wires to anything. **Tape or cap all unused wires singly.**
5. Use a linear regulated DC power supply, between 5 volts (60 mA peak) and 12 volts DC (120 mA peak).
6. Install the reader on the electrical utility box or other surface. Attach the reader to the electrical box with supplied screws (item c in the Parts List).
7. Hold the reader's top cover over the base reader, and snap the cover closed securely.
8. Power up the reader. The beeper sounds a single *Short* beep. The LED should be steady amber.
9. While the LED is amber, enter the 10-digit password (**914 369 8800**). There is a short beep with each keystroke. (For security, record this password and store it in a safe place.)
10. Immediately enter the 5-character code **#ABC#** for the site code (or facility code) that you will program into the host system to identify keypad PIN entry. "ABC" represents the 3-digit site code. There is a short beep with each keystroke.
  - Program the host system for 26-bit Wiegand format from keypad entry. The site code must be between 000 and 255.
  - If you do not enter the keypad's site code, the KP-6840 Revision E Reader-Keypad enters a default site code of 000.
  - The site code for the keypad may be the *same as* or *different from* the site code of the credentials (cards, keytags or wafers), depending on requirements of the host system or application.
11. If programming is successful, the beeper sounds 1 long beep. Then the LED is red to indicate standby mode.
12. If the beeper doesn't sound and the LED doesn't change to red, remove power from the reader, then repeat steps 8 to 11, above. Enter the password and the site-code selection code with a steady hand, pressing each key for at least *0.5 second*. Do not pause between the password and the 5-character code. Also, be sure that the **yellow** wire is disconnected from the panel and floating.
13. The LED color in standby mode may be changed from red to green, or from green to red, using a *Color Changer* card, available from AWID. Remove power from the reader for a few seconds; then restore power. While the LED is amber, present the Color Changer card to toggle the LED color at standby.

**Operation Modes** The KP-6840 Revision E Reader supports the following operation modes of the host system:

**Proximity plus PIN** .....Present proximity card first, then enter PIN on keypad.      **Proximity Only**.....Present proximity card only.  
**PIN plus Proximity** .....Enter PIN on keypad first, then present proximity card.      **PIN Only** .....Enter PIN on keypad only.

### Notes for Operation Modes:

- (a) For 26-bit Wiegand format, enter between 1 and 5 keystrokes. The PIN must be between 0 and 65535.
- (b) To cancel keypad PIN entry before completing the number, press the \* key.
- (c) To terminate keypad PIN entry after all keys have been pressed, press the #key.

(continued)

**Product Specifications**

Cable to Controller (for basic connections)

- 5, 6 or 7 conductors (not twisted pairs), stranded, 22 AWG, color-coded insulation, overall 100% shielded (Fig. 2)
- Length for Wiegand interface.....Up to 500 feet

Read Range (Metal Compensated)

- At 5 VDC.....Typically 6 inches (15 cm)
- At 12 VDC.....Typically 8 inches (20 cm)

Characteristics

- Indoor and Outdoor .....Rated for outdoor installations
- Operating Temperature Range .....-35° C to 65° C (-31° F to 150° F)
- Operating Humidity .....0 to 95% non-condensing

Operating Parameters

- Excitation Frequency .....125 kHz
- Wiegand Output.....Prox reader: 26 bits to 50 bits (as programmed in cards or tags)  
Keypad: 26 bits only

Certifications.....FCC Part 15 certification; Industry Canada

**Notes**

1. Two readers at the same door may need to be separated physically or shielded from each other for best operation. Request Technical Reference issue on “back-to-back readers” from AWID.
2. When the yellow wire is not used, the beeper remains active and under the reader’s internal control.
3. The Beeper, Hold, and LED lines are logic levels. *Never* apply power to them. They may be pulled to a low level (0 to 1.2 VDC) to enable their function. They must float at a high level (3.6 to 5.0 VDC) when not used.
4. KP-6840 Readers have both Wiegand-protocol and RS-232 serial interfaces. RS-232 data output applies to the card reader output only (not the keypad). For information on RS-232, contact AWID’s technical support.
5. For additional information, please visit AWID’s web site ([www.awid.com](http://www.awid.com)). Send all technical support questions to [support@awid.com](mailto:support@awid.com). Call AWID at **1-800-369-5533** from 8:00 a.m. to 7:00 p.m. Eastern Time.
6. FCC Compliance: This equipment has been tested and found to be in compliance with the limits for FCC part 15, Class A digital device. These limits are designed to provide reasonable protection against harmful interference when the equipment is operated in a commercial environment. This equipment generates, uses and can radiate radio frequency energy and, if not installed and used in accordance with instruction manual, may cause harmful interference with radio communications. Operation of this equipment in a residential area is likely to cause harmful interference in which case the user will be required to correct the interference at his own expense.  
The users are prohibited from making any change or modification to this product. Any modification to this product shall void the user’s authority to operate under FCC Part 15 Subpart A Section 15.21 regulations.  
This device complies with Part 15 of the FCC Rules. Operation is subject to the following two conditions: (1) This device may not cause harmful interference, and (2) this device must accept any interference received, including interference that may cause undesired operation.
7. Industry Canada Compliance: Operation is subject to the following two conditions: (1) This device may not cause harmful interference, and (2) this device must accept any interference, including interference that may cause undesired operation of the device.

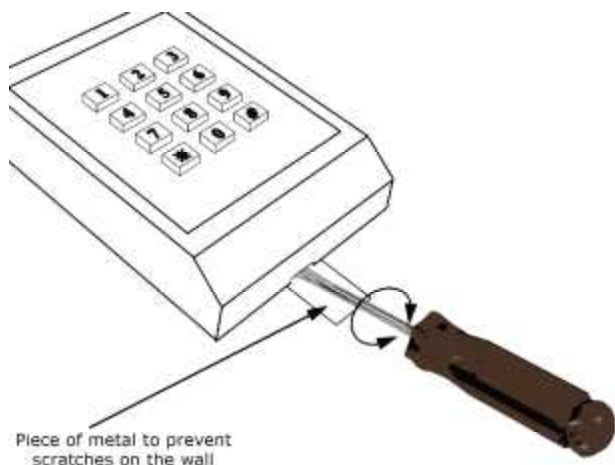

FIGURE 1: SNAPPING OPEN THE COVER

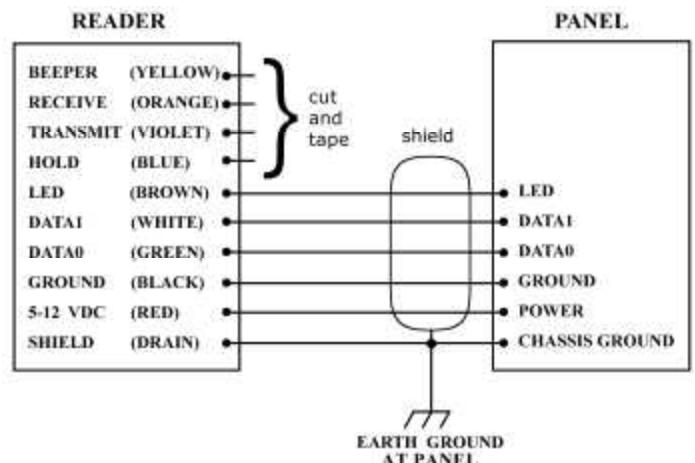

FIGURE 2: WIRING DIAGRAM (WIEGAND)