

Detex Corp, 302 Detex Drive, New Braunfels, Texas 78130 (830)629-2900/1-800-729-3839/ FAX(830)620-6711  
 E-Mail: detex@detex.com Internet: www.detex.com

## INSTALLATION INSTRUCTIONS FOR VERTICAL ROD ASSEMBLY, MODEL VRA-143

### GENERAL INFORMATION

The VRA-143 vertical rod assembly is designed for use on double doors in conjunction with the following Detex product:  
 Exit Control Lock Model ECL-230D.

#### NOTE

To locate the mounting holes for the ECL-230's and the VRA, use the templates provided with these instructions and disregard the templates provided with the ECL-230's.

The ECL-230's and the VRA can be used in any of the three arrangements shown.

#### Outside Key Control (OKC)

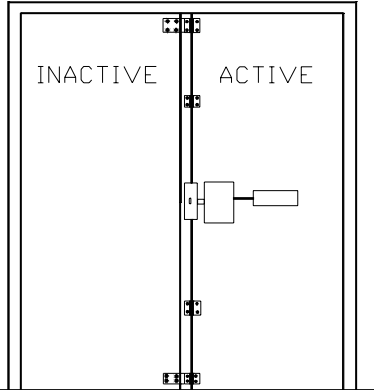
An OKC can be used on the active leaf of a type 'C' installation.  
 An OKC can also be used on a type 'B' or type 'D' installation but for entry only.

### TOOLS AND SUPPLIES REQUIRED

- Center punch to mark hole centers
- Hammer
- Drill motor and bits
- Tape to fasten templates
- Tape measure
- Screwdriver, blade type
- 7/8" diameter drill
- 1" diameter drill
- #10-24 tap

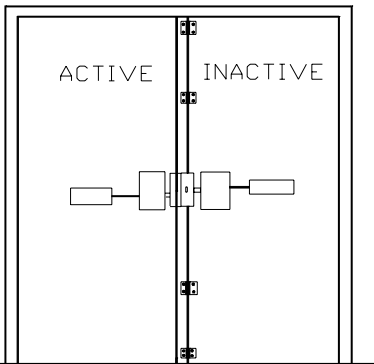
### EQUIVALENT METRIC DIMENSIONS

INCHES	MILLIMETERS
0.150	4
0.152	4
1/4	6
3/4	19
1	25
1-1/4	32



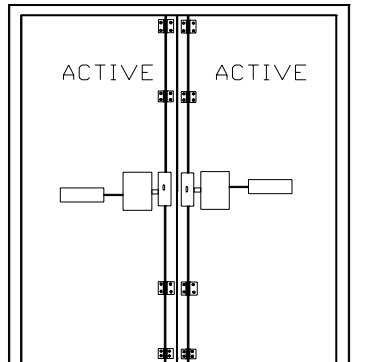
**FIGURE 1, TYPE B**

Active leaf opens both doors.  
 Overlap plates installed on the inactive leaf.



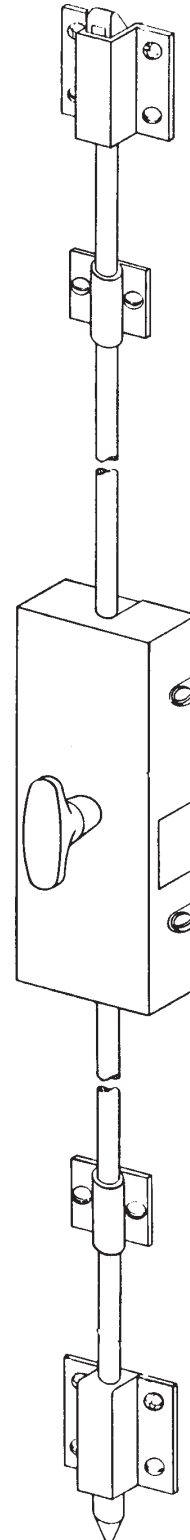
**FIGURE 2, TYPE C**

Either leaf opens first.  
 Strike plate installed on VRA door.  
 Lock on leaf without VRA must be ECL-230.



**FIGURE 3, TYPE D**

Each leaf is independent.



**FIGURE 4**

## TEMPLATES

Templates provided with these instructions include hole center locations for the three types of installations described on page 1.

For a type B installation, use templates A, B and E.

For a type C installation, use templates A, B and F.

For a type D installation, use templates C, D and E

Select the required templates and tape them to the door. Make sure that the door is firmly butted against the stop and mark the required hole centers.

## SCREWS AND DRILL SIZES

Several types of screws are supplied with this product. Some are for temporary use during the installation and are to be replaced with the permanent "one-way" screws after all adjustments have been completed as explained later.

#10 type AB thread-forming screws are supplied with the VRA for use in non-reinforced door areas. The recommended drill size for these screws is #24(0.152). For reinforced doors, #10-24 machine screws are supplied and the recommended tap-drill size is #25(0.150).

## OUTSIDE KEY CONTROL (OKC)

Instructions for installing the rim cylinder are included in the instructions provided with the exit control lock.

## UPPER AND LOWER STRIKES

Follow the instructions on the strike templates and mark the hole centers as shown. Produce a hole in the door frame and in the floor or threshold, about 3/4" deep. Drill the strike mounting holes.

Install the upper strike plate making sure that the raised flange is toward the door as shown in figure 5. Install the lower strike plate.

## BASE ASSEMBLY

Refer to figure 7 and install the base assembly on the door, oriented as shown, using four pan-head screws, 1" long. If a type-C installation, install the closed-back strike at this time. (The strike fits under the base assembly).

## LOWER ROD ASSEMBLY

Refer to figure 7 and assemble the lower rod (39"), jam nut, lower bolt, bolt housing, (open end down), and rod guide. The lower bolt will be adjusted later.

## UPPER ROD ASSEMBLY

Refer to figure 7 and assemble the upper rod, bolt housing, (open end up), upper bolt and rod guide. The upper bolt will be adjusted later.

## INSTALL LOWER ROD

Install the lower rod assembly as follows. Insert the upper end of the rod through the hole in the bottom of the base assembly and lower it until the lower bolt enters the lower strike plate. Insert a cotter pin in the bottom hole in the rod. Slip a spring then a washer onto the upper end of the rod and insert the end of the rod in the link in the base assembly. Fasten the rod to the link with a knurled head pin.

Fasten the lower bolt housing to the door using two **Phillips-head** screws. *One-way screws will be added after adjustment of the bolt.*

Place the handle on the square shaft in the base assembly and turn it to verify that there is no binding

Position the rod guide about midway between the base assembly and the lower bolt housing and mark the hole centers. Drill the holes and fasten the rod guide to the door with #10 x 3/4" oval-head screws.

Verify that there is no binding when the handle is turned.

## INSTALL UPPER ROD

Insert the lower end of the rod into the hole in the top of the base assembly. Slip a spring and washer onto the lower end of the rod and insert a cotter pin in the second hole from the bottom of the rod. Attach the rod to the link in the base assembly with a knurled pin.

Fasten the upper bolt housing to the door with two **Phillips-head** screws. *One-way screws will be added after adjustment of the upper bolt.*

Position the rod guide about midway between the top of the base assembly and the underside of the bolt housing. Mark the hole centers and drill the holes for the #10 screws. Install the rod guide with #10 x 3/4" oval-head screws. Verify that there is no binding

## BOLT ADJUSTMENT

To make the required adjustments, temporarily install the VRA handle on the square shaft in the base assembly. Turn the handle counterclockwise to the locked position and check the top and bottom bolt positions. The upper bolt must be adjusted so that the flat on the top side is butted to the upper strike plate as shown in figure 5. Adjust the bolt by screwing or unscrewing the rod. If the rod is too long, refer to figure 7 and cut the rod as shown.

The lower bolt must be adjusted so that the bolt enters the lower strike plate as shown in figure 6. Adjust the bolt by screwing or unscrewing it on the rod. Tighten the jam nut on the lower rod.

When all the adjustments are complete, operate the VRA handle to make sure that the mechanism works freely and the top and bottom bolts enter the strike plates properly when locked. Make sure that the top and bottom bolts clear the strike plates when the rods are retracted.

Replace the temporary screws in the top and bottom bolt housings with "one-way" screws.

#### **INSTALL COVER**

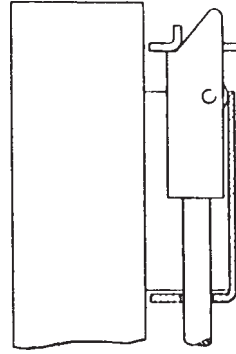
Remove the VRA handle and install the cover with two pan-head screws, 1/4" long. Install the handle.

#### **INSTALL ECL(S)**

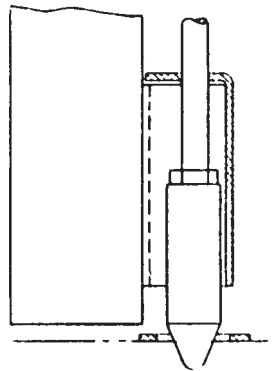
Refer to the instructions provided with the ECL-230 and install the product(s). If a type-C installation with an OKC, install the cylinder before installing the ECL-230.

#### **OVERLAP PLATES**

If a type-B installation., install the top and bottom overlap plates with two one-way screws and two Phillips-head screws each. See figure 7.

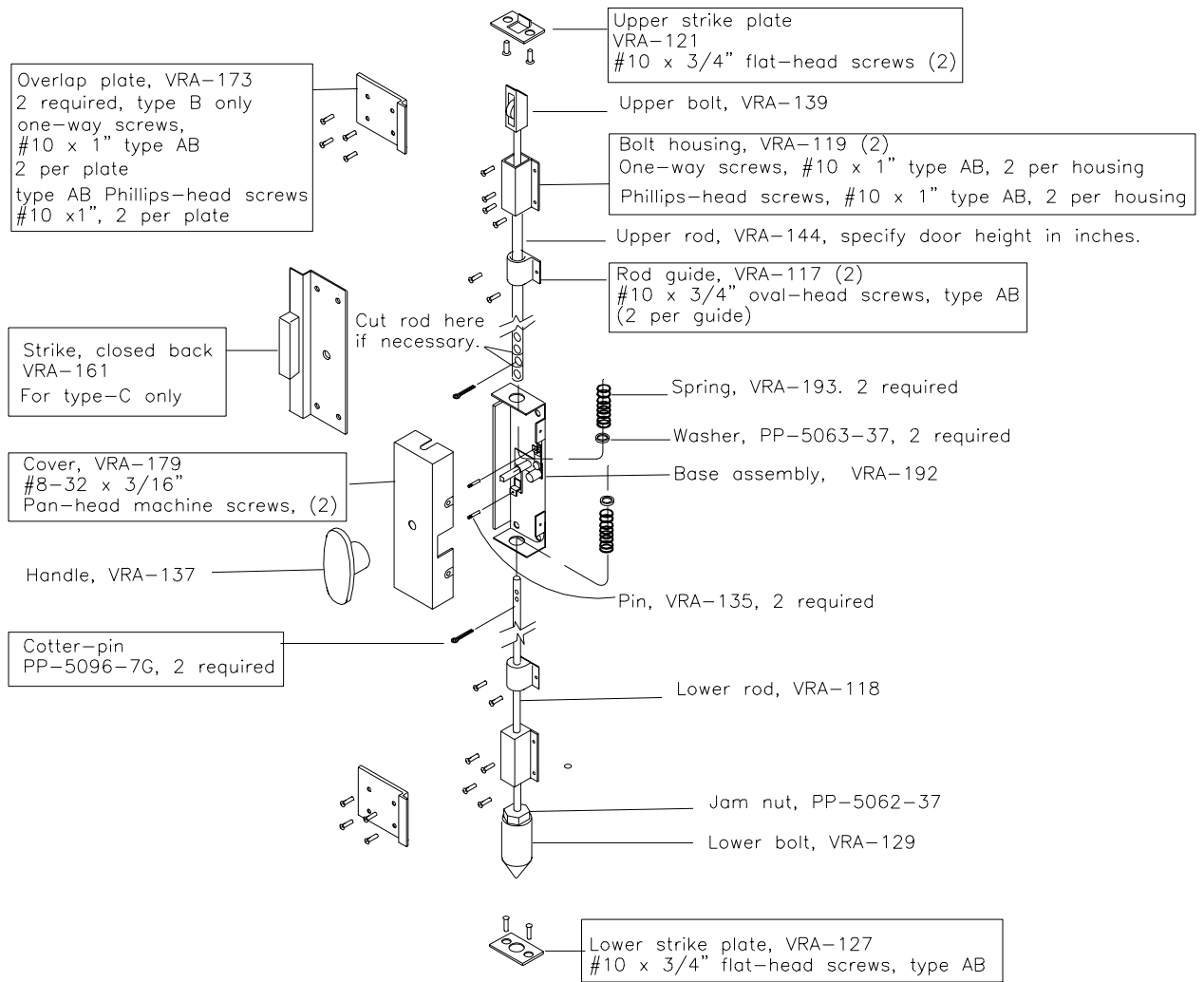


**FIGURE 5**



**FIGURE 6**

**PROBLEMS?**  
Contact Customer Service at  
**1-800-729-3839**



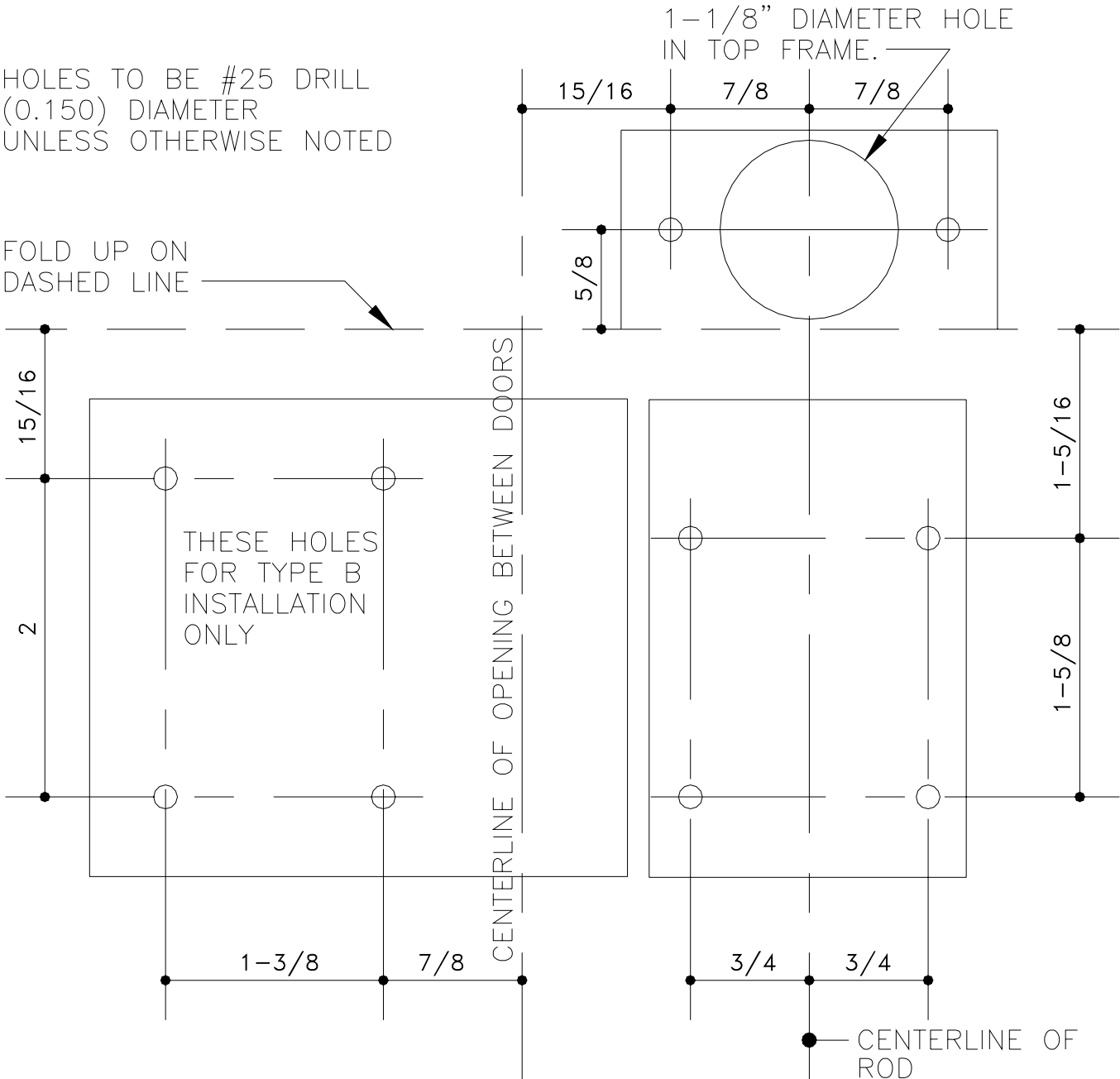
**FIGURE 7 ILLUSTRATED PARTS BREAKDOWN**

NOTE: DIMENSIONS MAY NOT BE ACCURATE WHEN PRINTING FROM WEBSITE  
PLEASE CONFIRM DIMENSIONS WITH RULER BEFORE USE

# TEMPLATE A, TOP OF DOOR VRA INSTALLED ON RH DOOR

HOLES TO BE #25 DRILL  
(0.150) DIAMETER  
UNLESS OTHERWISE NOTED

FOLD UP ON  
DASHED LINE

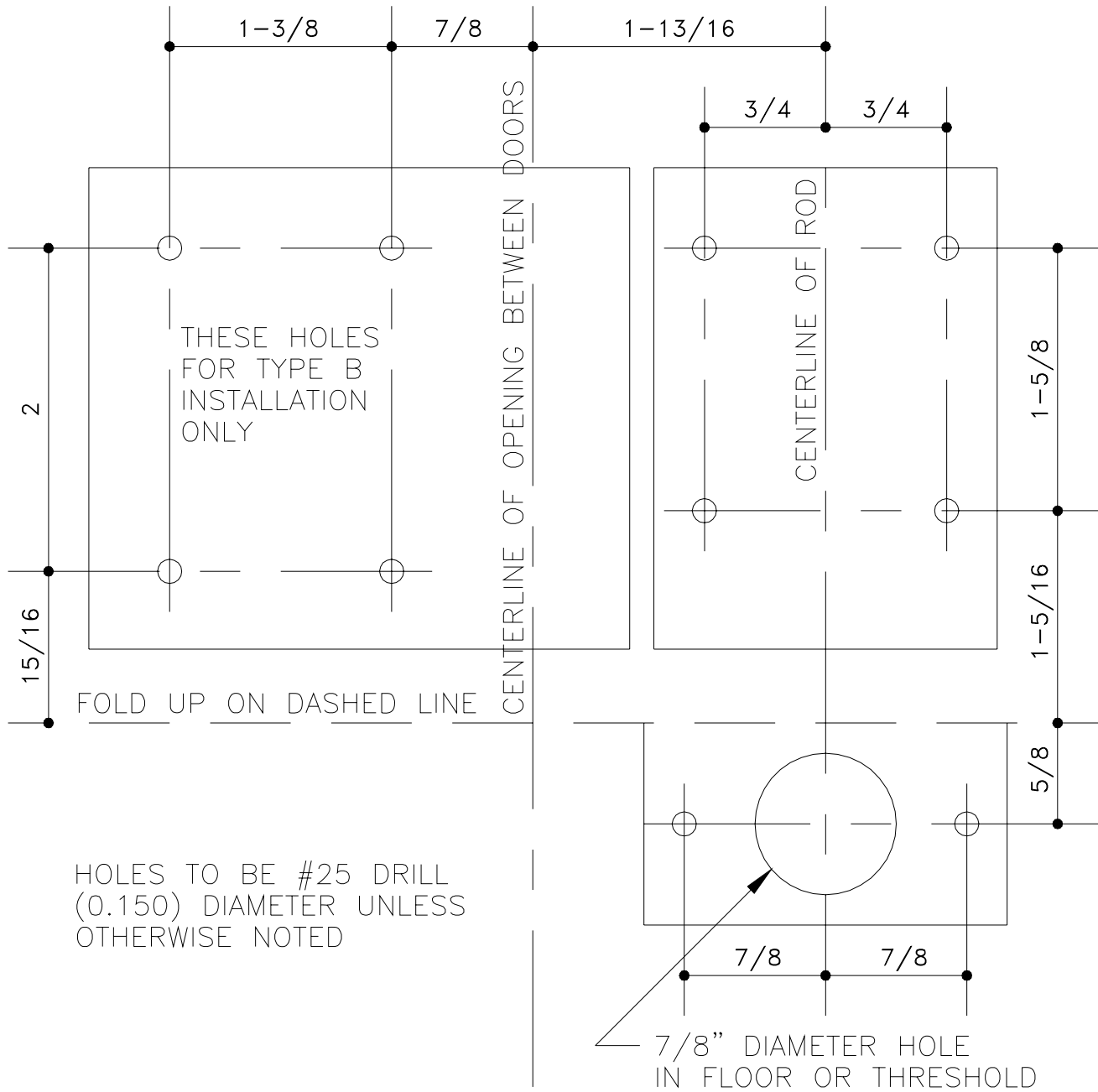


March 30, 2001

NOTE: DIMENSIONS MAY NOT BE ACCURATE WHEN PRINTING FROM WEBSITE

PLEASE CONFIRM DIMENSIONS WITH RULER BEFORE USE

# TEMPLATE B, BOTTOM OF DOOR VRA INSTALLED ON RH DOOR



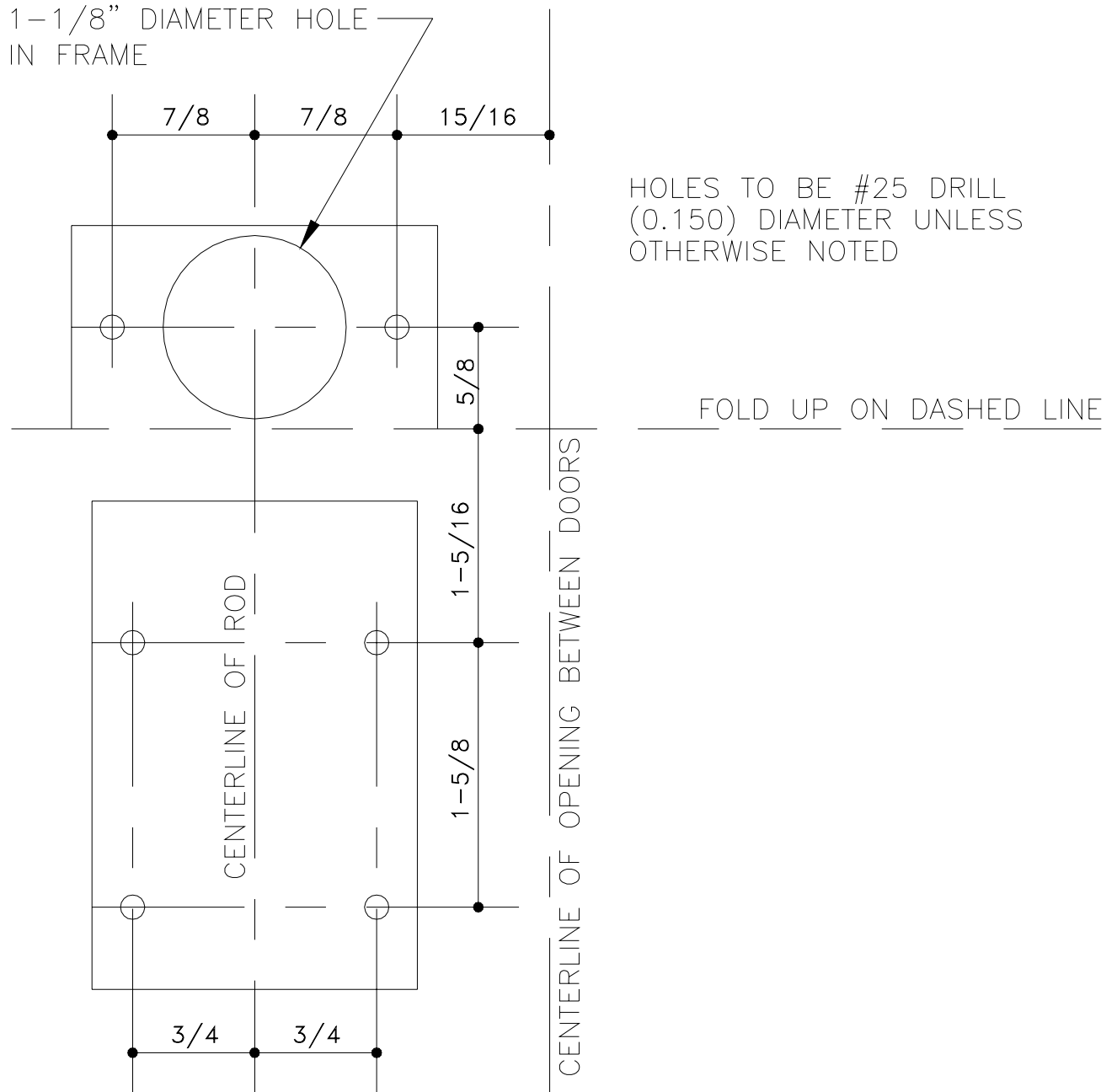
HOLES TO BE #25 DRILL  
(0.150) DIAMETER UNLESS  
OTHERWISE NOTED

March 30, 2001

NOTE: DIMENSIONS MAY NOT BE ACCURATE WHEN PRINTING FROM WEBSITE

PLEASE CONFIRM DIMENSIONS WITH RULER BEFORE USE

# TEMPLATE C, TOP OF DOOR VRA INSTALLED ON LH DOOR

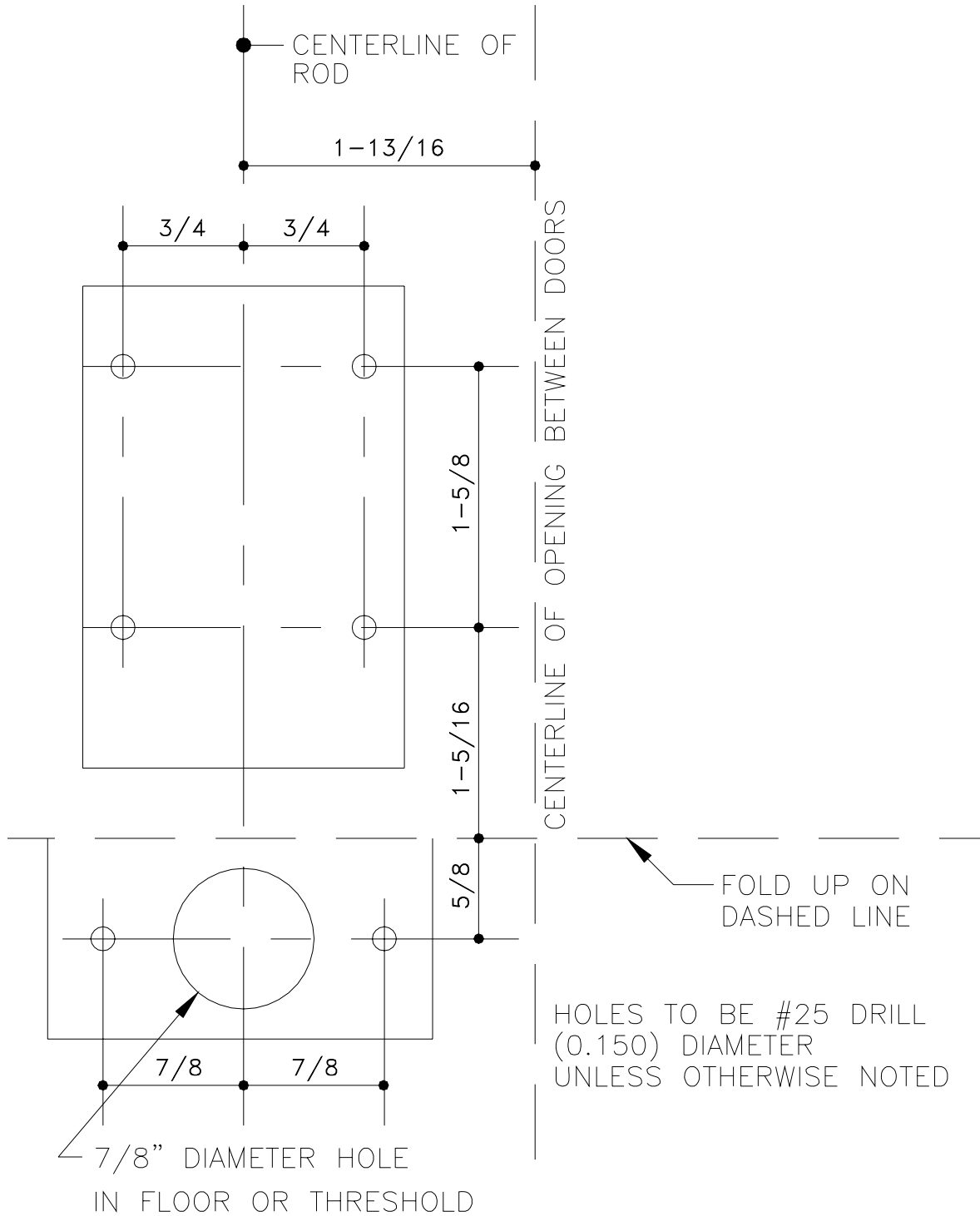


March 30, 2001

NOTE: DIMENSIONS MAY NOT BE ACCURATE WHEN PRINTING FROM WEBSITE

PLEASE CONFIRM DIMENSIONS WITH RULER BEFORE USE

# TEMPLATE D, BOTTOM OF DOOR VRA INSTALLED ON LH DOOR

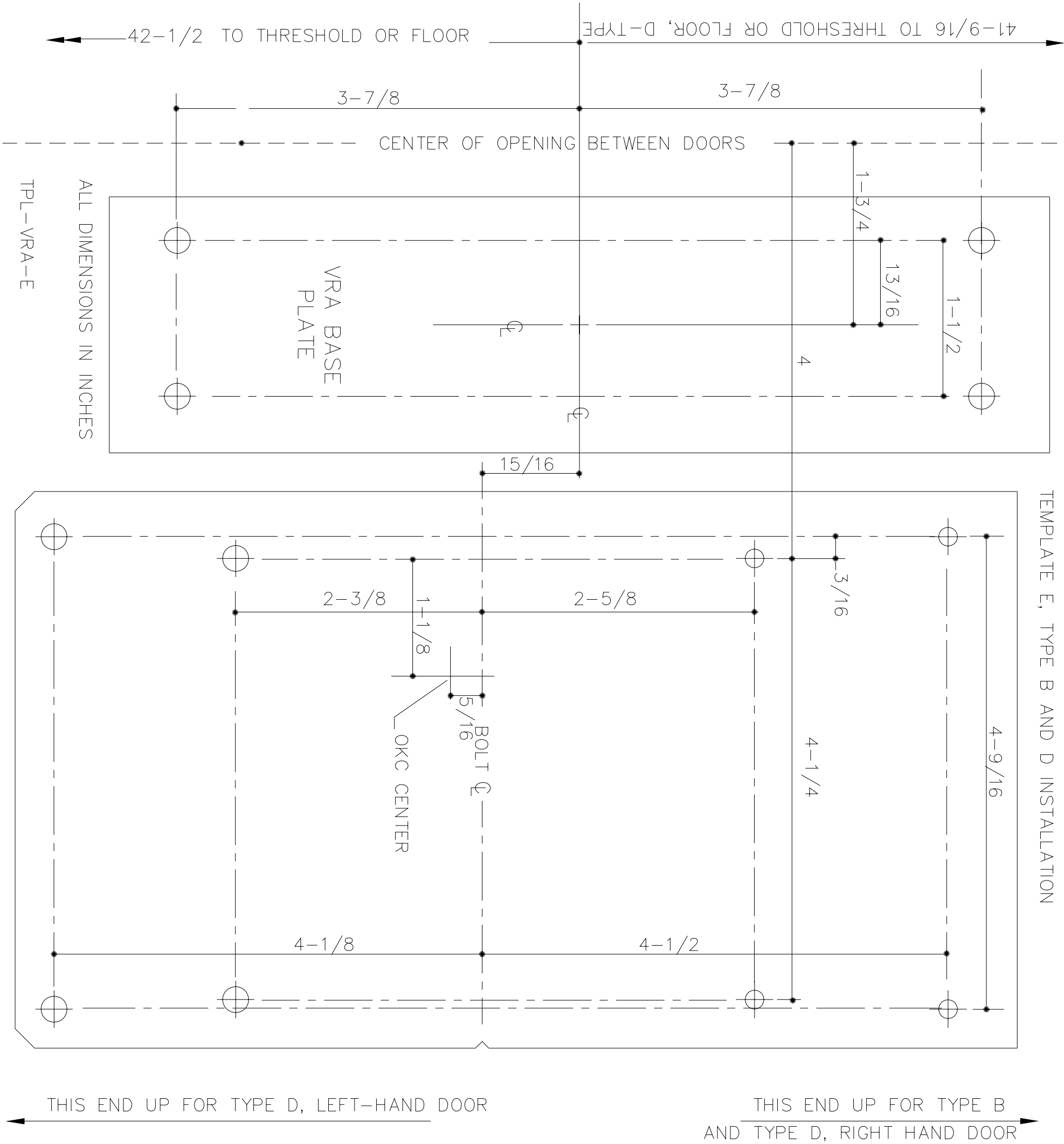


March 30, 2001



NOTE: DIMENSIONS MAY NOT BE ACCURATE WHEN PRINTING FROM WEBSITE

PLEASE CONFIRM DIMENSIONS WITH RULER BEFORE USE



NOTE: DIMENSIONS MAY NOT BE ACCURATE WHEN PRINTING FROM WEBSITE

PLEASE CONFIRM DIMENSIONS WITH RULER BEFORE USE

INSTALLATION TEMPLATE F, TYPE C INSTALLATION

