

80-9357-0110-020 (08-10)

Series 5710—Door Openings 85° to 110° or 111° to 180°  
Adjustable Arm and Slide Track Application  
Maximum Hinge Side Frame Reveal to 1/8" (3mm)  
Hinge (Pull) Side of Door Installation

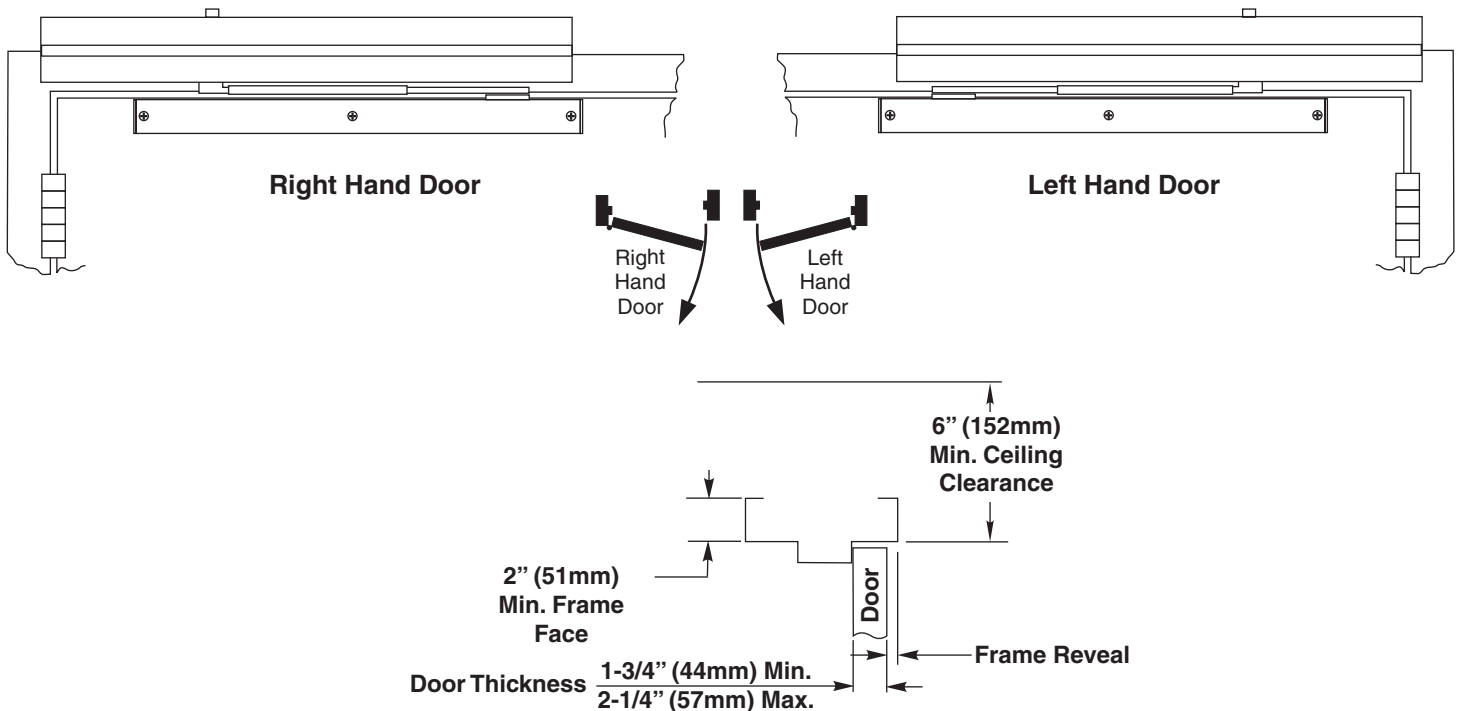

### Requirements

- U.L. labeled fire or smoke barrier door assemblies require that the 120VAC (60Hz) power input to the *LEO* door operator be supplied through normally closed alarm contacts of the alarm system/alarm panel.
- Power input to *LEO* door operator must be 120 VAC (60Hz) to terminals HOT and COM at terminal strip T1. Earthground (GND) to green screw on Backplate.
- All wiring must conform to standard wiring practice in accordance with national and local wiring codes.
- Note: Unless otherwise noted, all dimensions are given in inches (millimeters).
- Minimum suggested and required material thickness for hollow metal frames (skin plus reinforcement) is charted on Page 2.
- For wiring refer to Wiring Instructions on Pages 5 thru 8.
- Unit is Non-Handed.
- Door must be hung on butt hinges [5" (127mm) max. width]. A separate door and frame preparation template will be required for other conditions.
- Door must swing freely through the entire opening and closing cycle before beginning the installation.
- Use of a supplemental door stop (by others) is always recommended.

#### WARNING

120 HIGH VOLT POTENTIAL PRESENT. MAKE SURE POWER IS TURNED OFF DURING INSTALLATION PROCEDURE.

**CAUTION**

An incorrectly installed or improperly adjusted door operator can cause property damage or personal injury. These instructions should be followed to avoid the possibility of misapplication or misadjustment.

**CAUTION**

Requirements.....	1	Input Power Configuration .....	5
General Templating Information .....	2	Inverter Details .....	6
Installation Template.....	2	Wiring Diagram - Standard Function with Switches.....	6
Component Layout.....	3	Wiring Diagram - Optional Radio Frequency Function.....	7
Installation Sequence.....	3	Wiring Diagram - Fail Safe / Fail Secure Electric Strike.....	7
Installation Sequence Continued.....	4	Wiring Diagram - Fail Safe Electromagnetic Lock.....	8
General Electrical Data.....	5	A.D.A / UL Information.....	8

# General Templating Information

**WARNING:** Make sure that (120V, 60Hz) input power is turned off at facility's main circuit breaker before proceeding with installation.

## General Templating Information

- Before beginning the installation, verify that the door frame is properly reinforced and is well anchored in the wall.
- Unreinforced hollow metal frames and aluminum frames should be prepared and fitted with 1/4-20 blind rivet nuts, furnished by others.
- Concealed electrical conduit and concealed switch or sensor wires should be pulled to the frame before proceeding.

## Fasteners for Frame

- 1/4-20 Machine screws for hollow metal and aluminum.
- No. 14x2-3/4" (70mm) long sheet metal screws for wood.

## Fasteners for Door

- 1/4-20 Machine screws.
- 3/8" diameter x 1-5/8" (41mm) long sex nut.

## Template

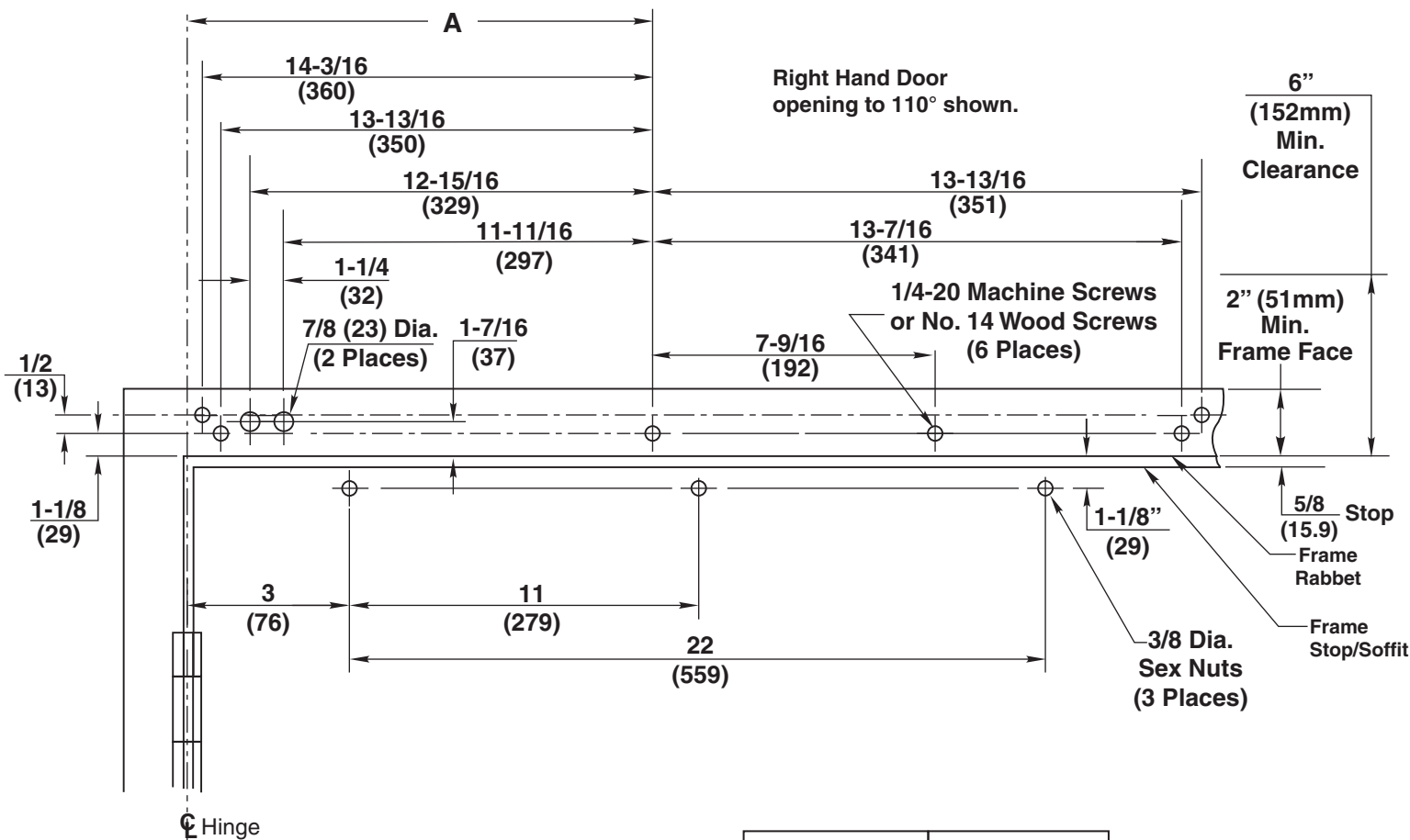

Hollow Metal Door Frame Reinforcing		
Frame Material	Reinforcing	
	Recommended	Min. Required
12 Ga. .1046 (2.66)	12 Ga. .1046 (2.66)	18 Ga. .0478 (1.21)
14 Ga. .0747 (1.90)	10 Ga. .1343 (3.41)	12 Ga. .1046 (2.66)
16 Ga. .0598 (1.52)	10 Ga. .1343 (3.41)	12 Ga. .1046 (2.66)
18 Ga. .0478 (1.21)	8 Ga. .1644 (4.18)	10 Ga. .1343 (3.41)

Door Opening Angle	Dim "A"
Up to 110°	15-1/2 (394)
111° to 180°	13-1/4 (337)

**Notes:**

- All dimensions are given in inches (mm).
- Thickness recommended for reinforcements in hollow metal doors and frames is charted at the left of this page.
- Do not scale drawing.
- Left hand door shown.
- This template information based upon use of 5" (127mm) maximum width butt hinges. A separate template is required for other conditions.
- Maximum frame reveal is 6-7/8" (175mm) for this application.
- Conduit hole nearest the hinge is suggested for 120 VAC power input.

# Component Layout

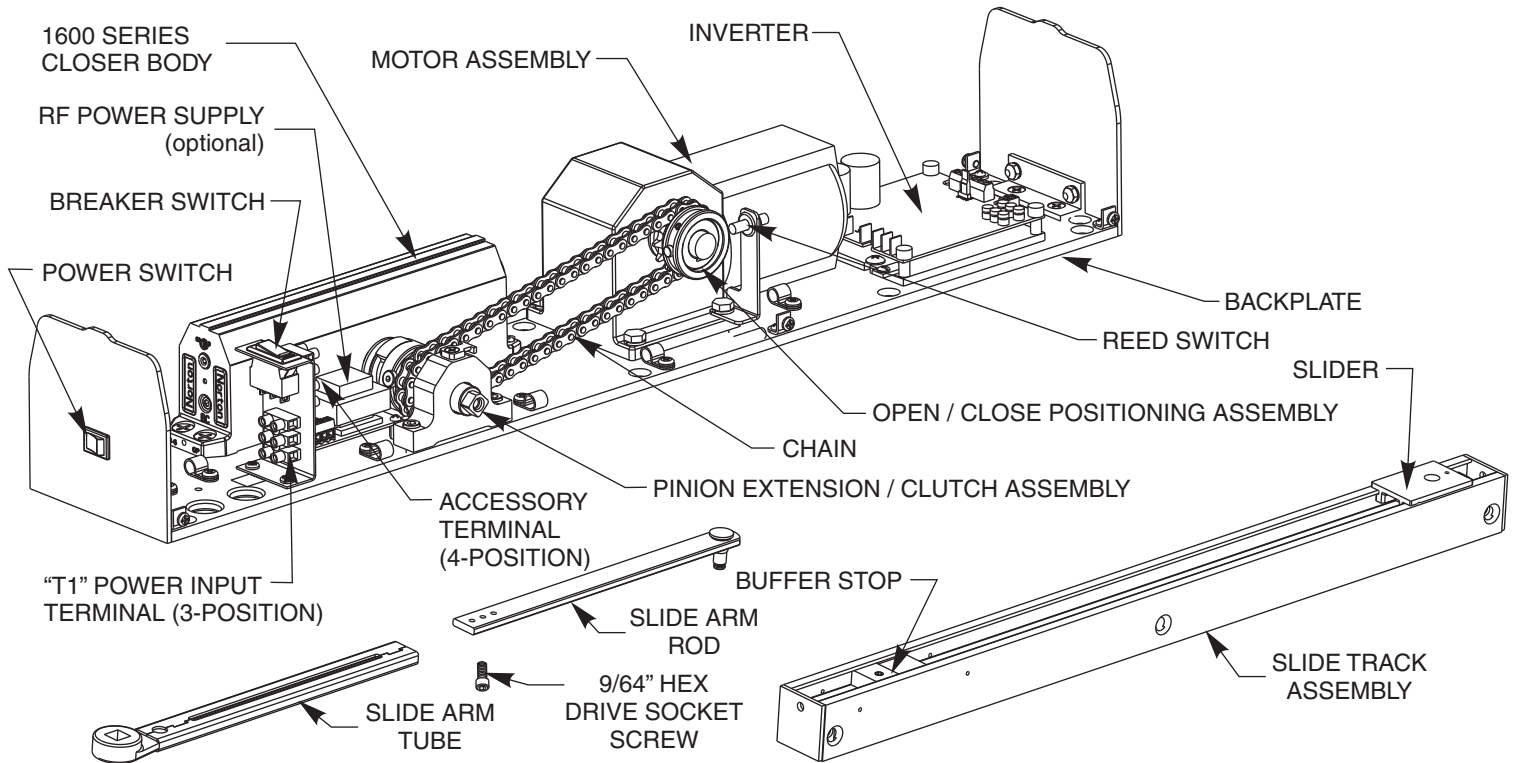

## Installation Sequence

**Step 1:** Determine hand of door from illustration on Page 1.

**Step 2:** Using template, (Page 2), locate and prepare holes in the frame & door:

### Frame

- A. Prepare **six (6)** holes for 1/4-20 machine screws or No. 14 x 2-3/4" (70mm) wood screws. Blind rivet nuts (by others) are suggested for unreinforced hollow metal frames or for aluminum frames.
- B. **Concealed Wired Units Only:** Two (2) 7/8" (22mm) diameter holes for conduit, for power input and for switch/sensor wires.  
**NOTE:** On new construction these holes will generally be drilled by the frame supplier at their shop or at the time the frame is installed in the wall.

### Door

- C. Prepare **three (3)** holes for 3/8" diameter sex nuts. Standard units are supplied with sex nuts and screws for 1-3/4" (44mm) thick door. Sex nuts and screws for other door thicknesses are available to order.

**Step 3:** Remove cover from the unit and set cover & cover screws aside.

**Step 4:** Mount unit to door frame. Select A or B below.

- A. **Concealed Wired Units Only:** Connect conduit to frame side of backplate. Fasten unit to door frame (seven screws).
- B. **Surface Wired Units Only:** Fasten unit to door frame (seven screws). Mount conduit bracket (found in screw pack) to unit's backplate with two screws provided. Connect wiring conduit to bracket.

**Step 5:** Mount track assembly to door using 3 1/4-20 screws & sex nuts with buffer assembly toward hinge. Open part of track to face top of door.

**Step 6:** Insert slide arm rod into slide arm tube setting the distance between the pinion square and the slide stud at 13-1/2" (343). Install 9/64" hex drive socket head screw from screw pack. (See illustration upper right)

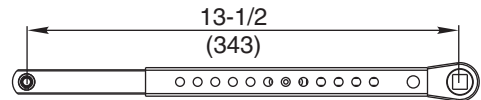

Note: Center threaded hole of slider arm should align with seventh hole of the slider tube

**Step 7:** Using an adjustable wrench, rotate pinion 45° toward hinge, as shown below. With the arm assembly parallel to the door, secure arm to pinion when square of the pinion aligns with the square in the arm. Secure with countersunk washer and 1/4-20 Flat Head Screw (with thread lock) provided. Tighten screw with 7/16" wrench or socket.

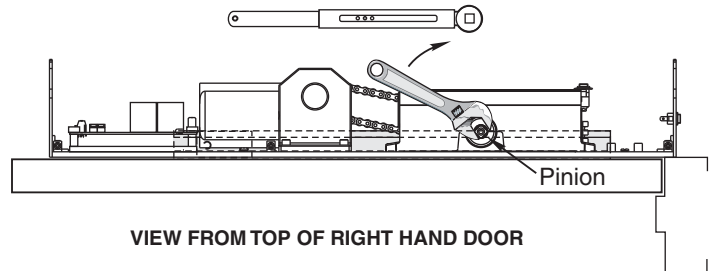

**Step 8:** Insert arm stud into slide block in track assembly. Secure by pushing in on the retainer clip that extends from the slide block in the track, until it is flush with the slide block (see illustration below).

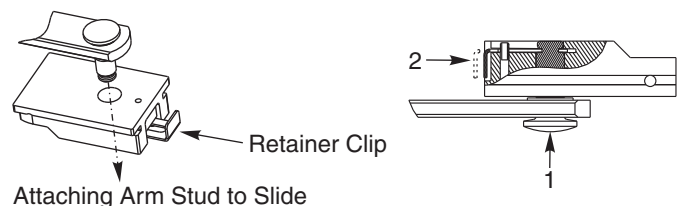

## Installation Sequence Continued

**Step 9:** Adjust closing power of unit (See Fig. 3) - Using a 1/8" allen wrench, turn the power adjustment shaft clockwise to increase door closing power. Door control is shipped set at midpoint of power setting. Maximum closing power can be achieved with 8 (360°) clockwise turns of the power adjustment screw.

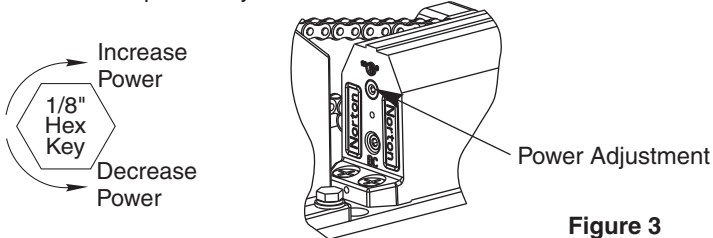

**Step 10:** Adjust Hydraulic valves using a 1/8" hex wrench to obtain proper door closing speeds. See following illustrations.

**Closing Cycle** – Make adjustments, as necessary, to the Sweep Speed "S" valve and Latch Speed "L" valve. See Fig. 4 below for location of valves. Turn valves clockwise to reduce speed, counter clockwise to increase speed.

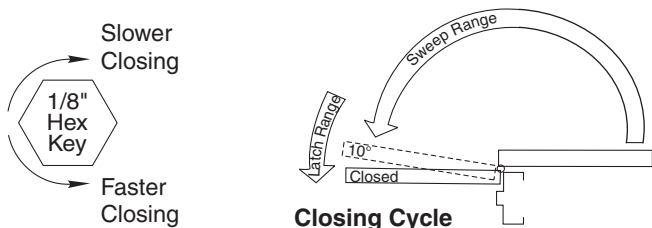

**Opening Cycle** – Adjust Backcheck, "B" valve, as necessary, for hydraulic resistance to door opening in the backcheck range. See illustration in Fig. 4 at bottom of this page for location of valve.

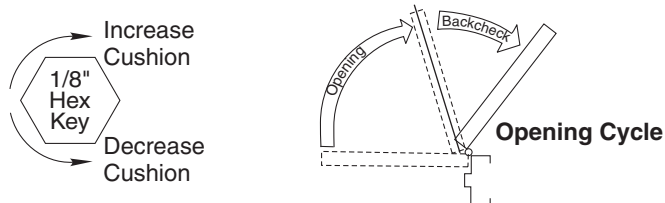

**NOTE:** Too much Backcheck, "B" valve, can affect the operation of the units pump, preventing units from fully opening the door. This valve may require fine tuning after all other adjustments have been made.

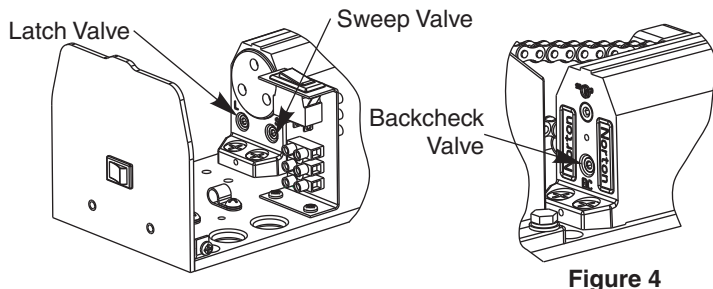

**Note:** A.D.A. requires that from an open position of 70°, the door will take at least 3 seconds to move to a point 3" (75mm) from the latched position, measured at the leading edge of the door.

**Step 11:** Make wiring connections using Wiring Instructions on Page 5.

**Step 12:** Turn on facility's main circuit breaker.

**Step 13:** Turn power to unit on at the Unit Power Switch and turn the Breaker Switch to "RESET".

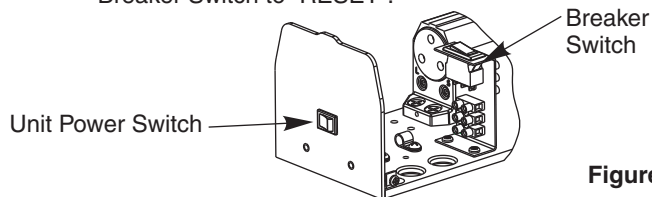

**Step 14:** Using a short jumper cable, jump terminals 1 and 2, see Fig. 6 below, to activate unit. When door reaches 20°, switch Breaker Switch to "OFF" position cutting power to the unit. Allow door to fully close (door may be manually pulled closed).

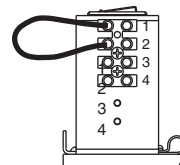

**Step 15:** Adjust Closing Position Magnet (See Fig. 7) - With door in the closed position, use finger to slide Closed Position Magnet so it aligns directly with the Reed Switch.

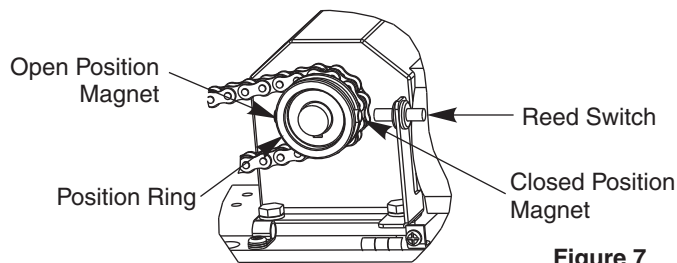

**Step 16:** Adjust Open Position Magnet - Use fingers to slide Open Position Magnet 180° from Open Position Magnet.

**Step 17:** Flip Breaker Switch to "RESET" to turn power on. Jump terminals 1 and 2 (as shown in Fig. 6) to activate door. Note open position of the door. Allow door to close.

**Step 18:** Use finger to readjust the Open Position Magnet to desired door open position.

**Step 19:** Repeat Step 17 to verify door open position.

**Step 20:** Make all connections necessary for any accessories to the 4-position Accessory Terminal (see Pages 6 - 8).

**Step 21:** Make necessary adjustments to inverter (see Page 6). Replace cover and cover screws.

# General Electrical Data

- Maximum current draw of unit is 0.6 amps.
- Breaker Switch protects the motor assembly and inverter; and has a 5 amp rating.
- Maximum wire size is:
  - 12AWG at terminals HOT and COM (120VAC; 60Hz) on "T1" Power Input Terminal.
  - 14AWG at terminals 1 thru 4 on Accessory Terminal .
  - 18AWG at terminals 22 thru 25 on "T1" Power Input Terminal.

## Input Power Configurations

### CONCEALED WIRING

Thread conduit fitting(s) into backplate as shown. A second conduit fitting is required for low voltage control wiring. CHECK LOCAL CODES. Pull conduit out of header and attach to conduit fittings before mounting Operator to door frame. Attach incoming ground wire to backplate with ground screw as illustrated in "Surface Wiring" illustration to the Right.

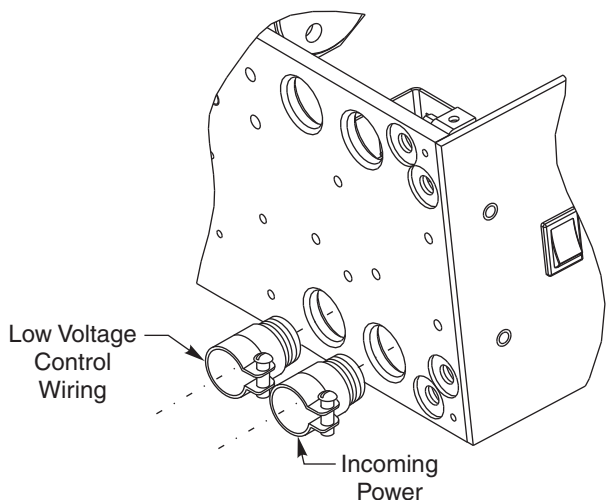

### SURFACE WIRING

An optional bracket is provided for use with surface wiring. Remove the two cable clamp screws and slip the bracket under the cable clamps. Push the cable clamp screw through the bracket holes and tighten. 1/2" conduit fittings can now be installed on the bracket. Attach incoming ground wire to backplate with ground screw as illustrated below.

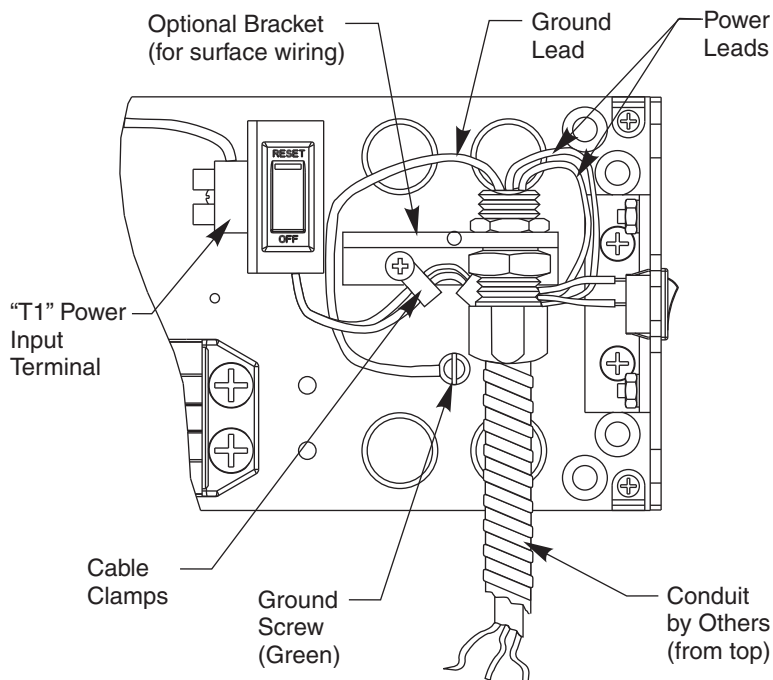

**Ground Wire Connection** – Ground wire must be secured to backplate under head of (green) ground screw nearest to "T1" Power Input Terminal. Screw labeled "GND".

Terminal	Description
COM	Common power lead
HOT	Hot power lead
25	Circuit Breaker
24	Switch
23	Circuit Breaker
22	Common connection to Circuit Breaker / Inverter

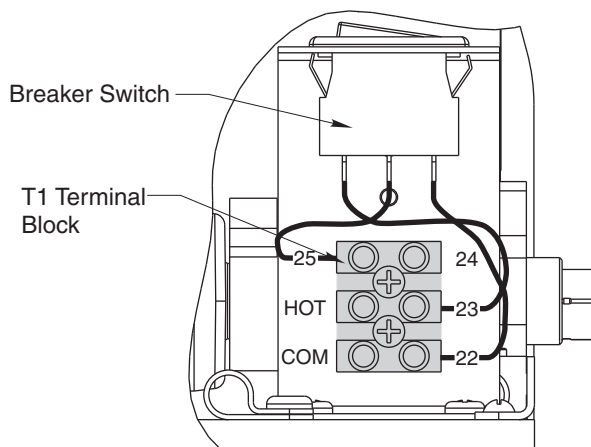



# Inverter Details

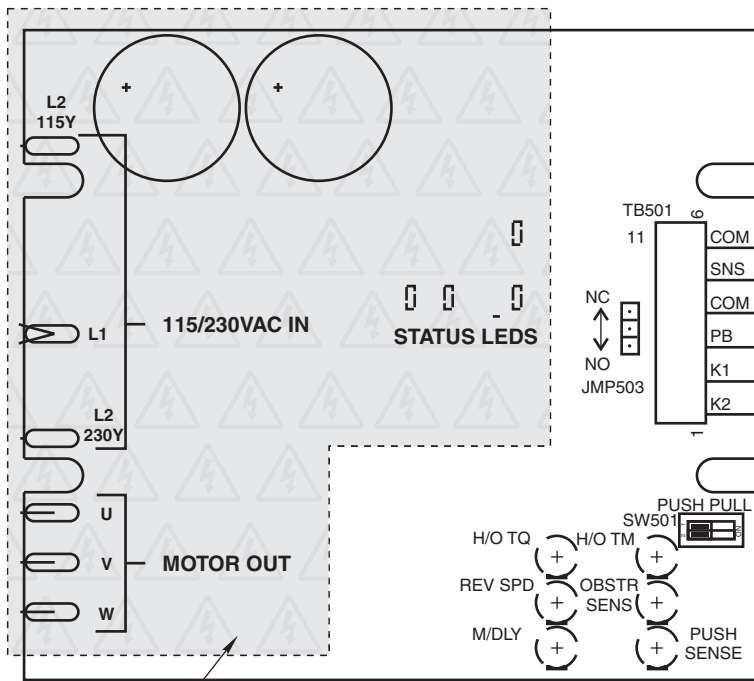

POT	DESCRIPTION	FUNCTION
M/DLY	Motor Delay on Opening	CW - Increase CCW - Decrease
OBSTR SENS	Obstruction Detection on Open	CW - Increase CCW - Decrease
REV SPD	Motor Reversing Speed	CW - Increase CCW - Decrease
H/O TM	Hold Open Time (5 - 30 Seconds)	CW - Increase CCW - Decrease
H/O TQ	Motor Torque at Hold Open Position	CW - Increase CCW - Decrease
PUSH SENSE	Push Recognition Sensitivity	CW - Increase CCW - Decrease

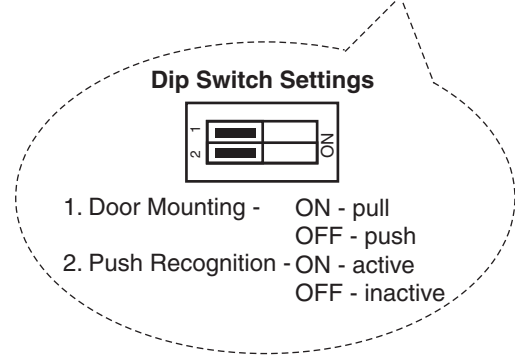

**WARNING**  
Electric  
Shock Risk

**WARNING**

120 HIGH VOLT POTENTIAL PRESENT. MAKE SURE POWER IS TURNED OFF DURING INSTALLATION PROCEDURE.

(Adjustments made in the shaded area should be performed by Authorized Factory Personnel.)

**Inverter Adjustments:**

- Based on function adjustment desired, use table above to determine which POT is to be adjusted.

## Standard Function with Switches

**Notes:**

- Power input to Door Operator Unit is at "T1" Power Input Terminal (not shown) 120VAC 60Hz.

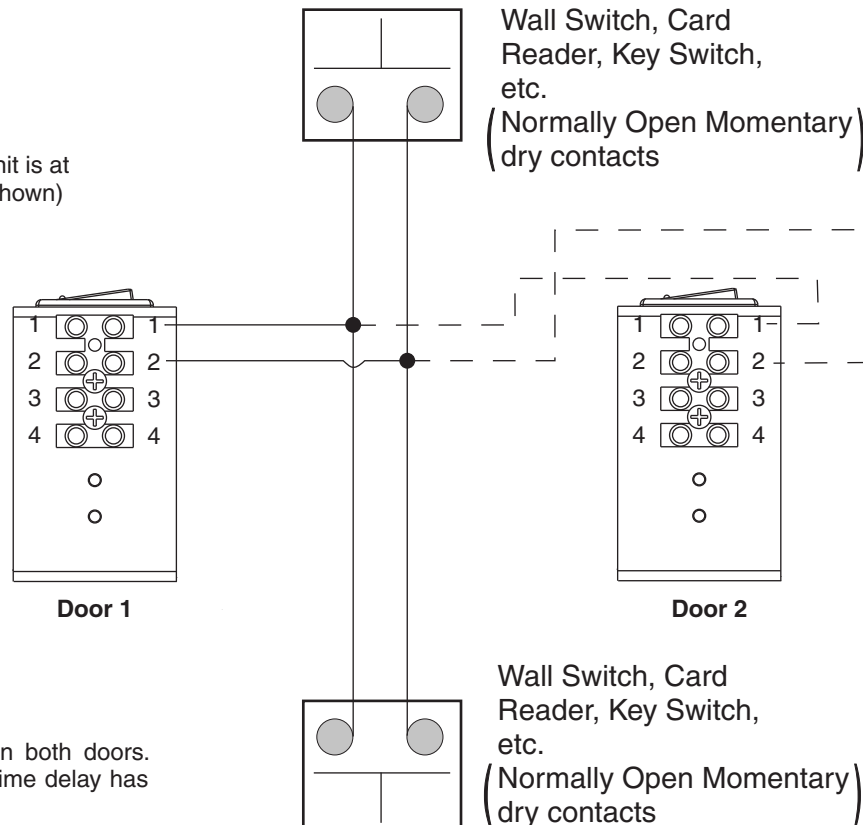

**Operation:**

- Doors are normally closed.
- Activating either switch will open both doors. Door will close after hold open time delay has elapsed.

# Radio Frequency Function Option

**Notes:**

1. Power input to Door Operator Unit is at "T1" Power Input Terminal (not shown) 120VAC 60Hz.
2. Radio Frequency Feature can be purchased as a separate kit.

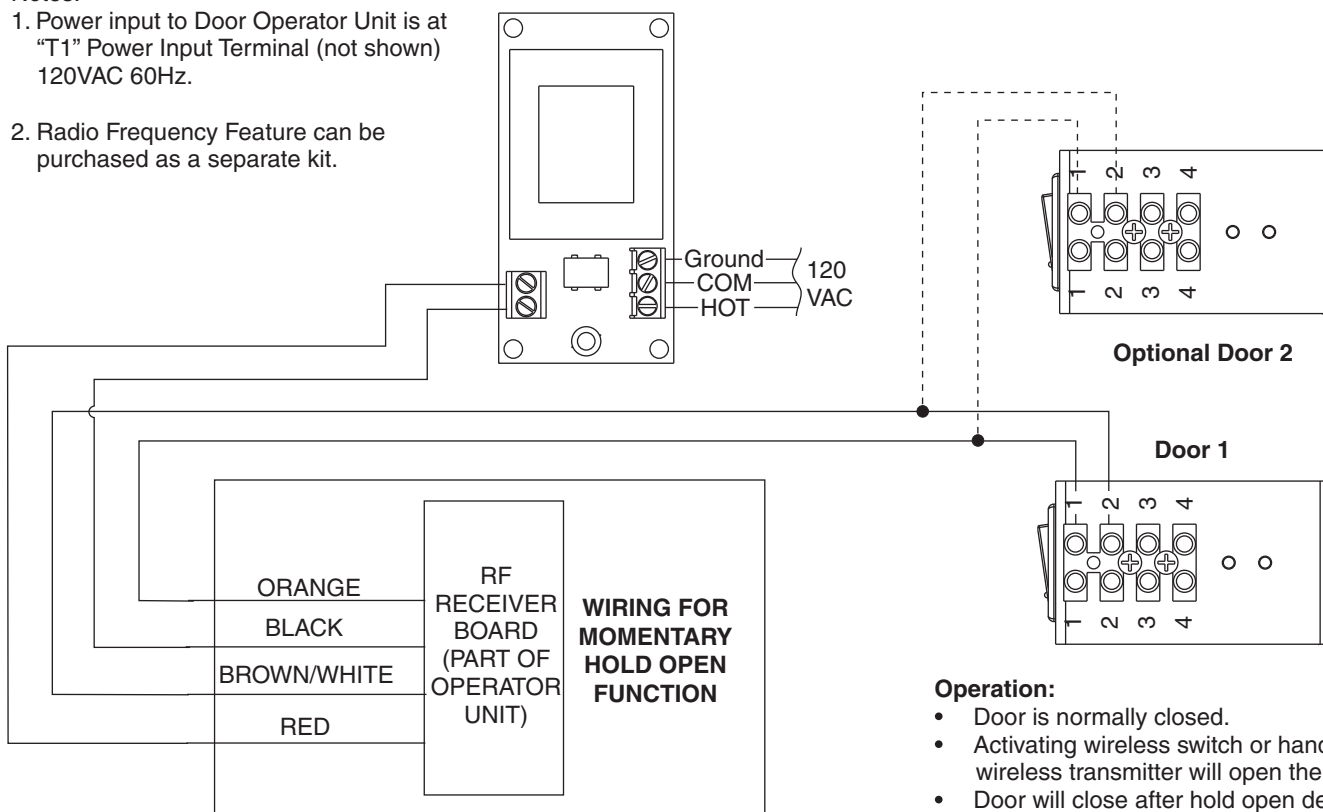

**Operation:**

- Door is normally closed.
- Activating wireless switch or hand held wireless transmitter will open the door.
- Door will close after hold open delay elapses.

# Fail Secure / Fail Safe Electric Strike Wiring

**Notes:**

1. Power input to Door Operator Unit is at "T1" Power Input Terminal (not shown) 120VAC 60Hz.
2. Unit's Relay Rating for strike interface: 30VDC @ 1A or 125VAC @ .5A

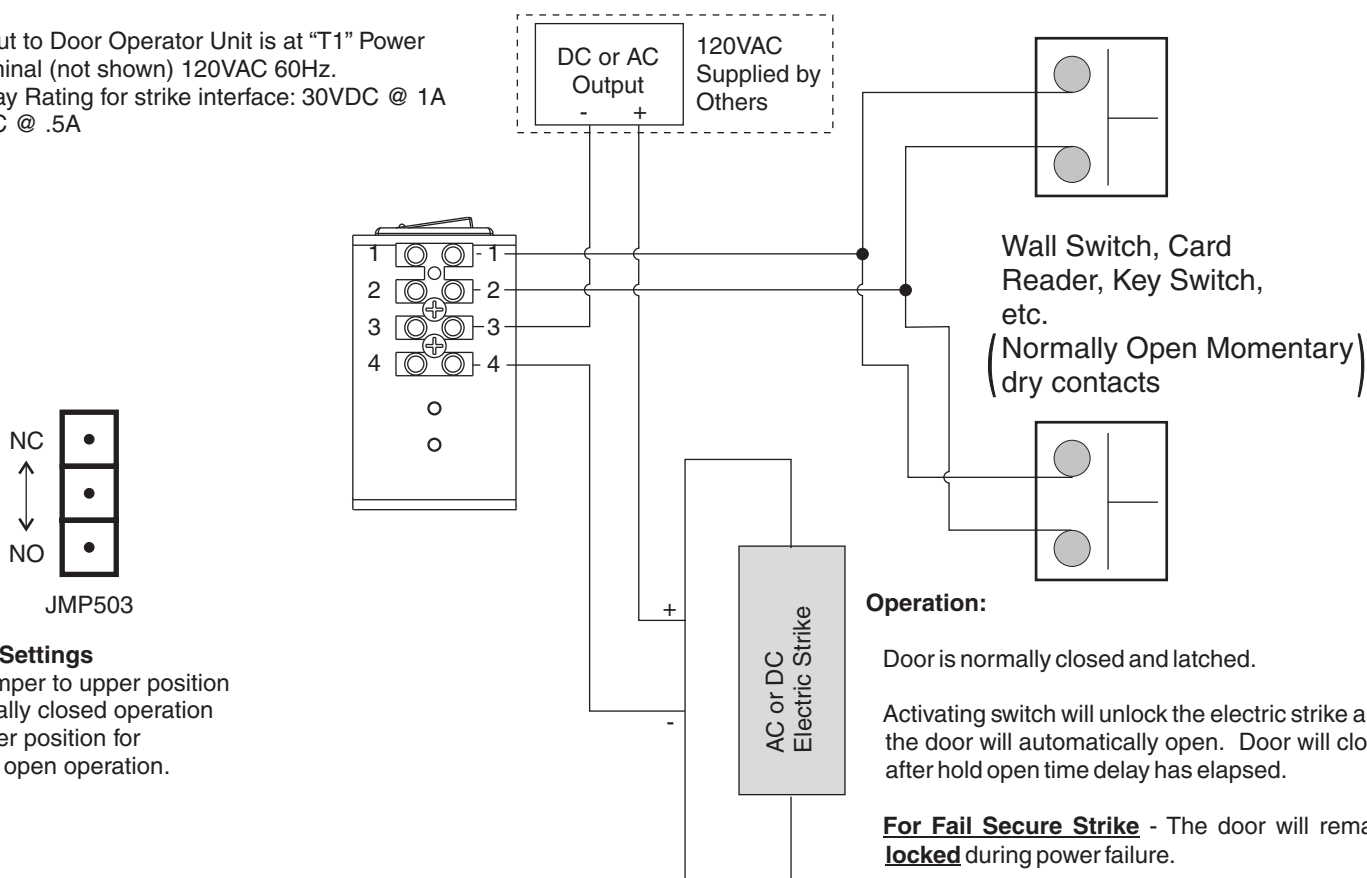

**Operation:**

Door is normally closed and latched. Activating switch will unlock the electric strike and the door will automatically open. Door will close after hold open time delay has elapsed.

**For Fail Secure Strike** - The door will remain **locked** during power failure.

• **For Fail Safe Strike** - The door will remain **unlocked** during power failure.

# Fail Safe Electromagnetic Lock 24VDC Wiring

**Notes:**

1. Power input to Door Operator Unit is at "T1" Power Input Terminal (not shown) 120VAC 60Hz.
2. Unit's Relay Rating: 30VDC @ 1A or 125VAC @ .5A

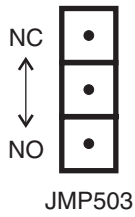

**Jumper Settings**

Place jumper to upper position for normally closed operation or to lower position for normally open operation.

**Operation:**

Door is normally closed and latched.

Activating switch will cut power to mag lock and the door will automatically open. Door will close after hold open time delay has elapsed.

- The door will **unlock** during power failure.

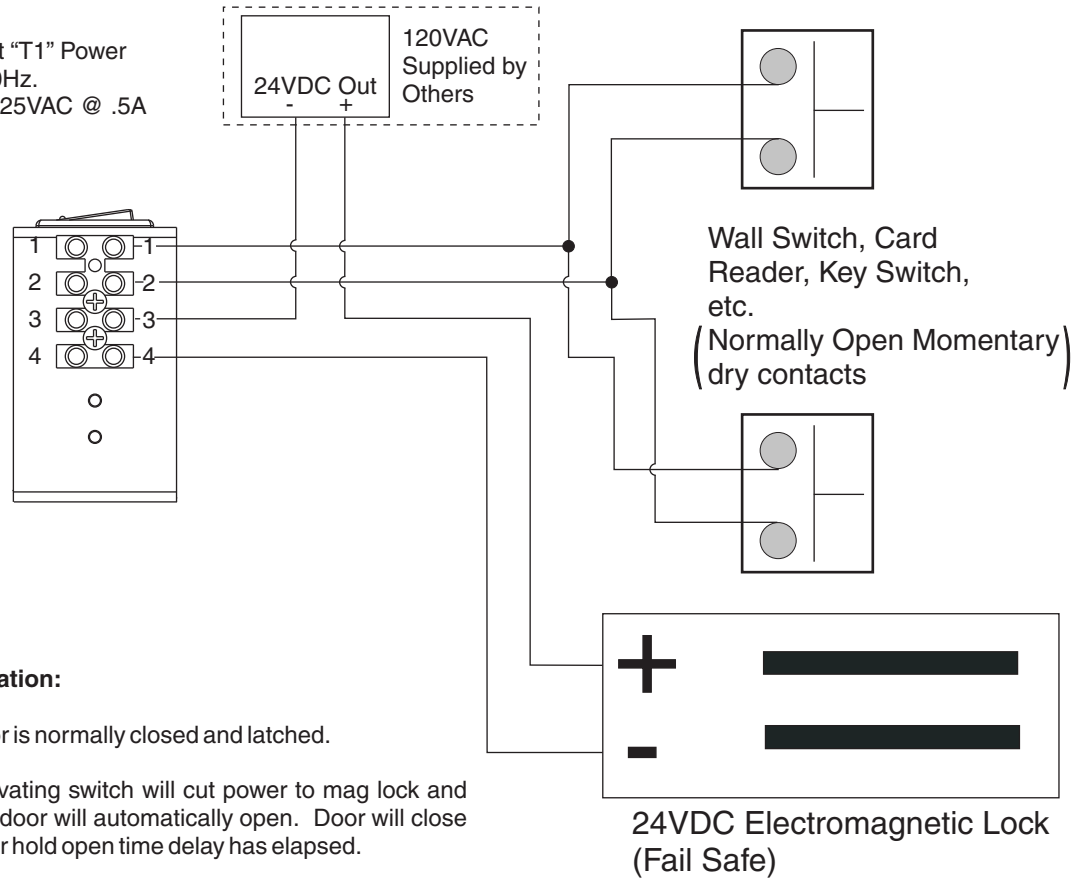

## A.D.A / UL

**Americans With Disabilities Act (A.D.A.)**

These door operators can be installed and adjusted to conform with A.D.A. regulations.

**ANSI Standards**



**ANSI A117.1** – These door operators permit door assemblies to conform to the requirements of this specification "for buildings and facilities – **providing accessibility and usability for physically handicapped people**".

- **ANSI A156.19** – These products are designed to conform to this specification "**for power assist and low energy power operated doors**".
  - "PAS" Function is designed to meet or exceed all of the requirements for the "Power Assist Door".
  - "POR" Function is designed to meet or exceed all of the requirements for the "Low Energy Power Operated Door".

**U.L. Listing**



**Underwriters Laboratories, Inc. listed for use on fire and smoke barrier door assemblies when the 120VAC (60Hz) power input is supplied through the normally closed alarm contacts of a compatible UL Listed alarm system or alarm panel.**



**ASSA ABLOY**

ASSA ABLOY, the global leader in door opening solutions

3000 Highway 74 East • Monroe, NC 28112

Tel: (877)-974-2255 • Fax: (800)-338-0965

www.nortondoortcontrols.com

Norton® is a registered trademark of Yale Security Inc., an ASSA ABLOY Group company.  
 Copyright © 2005, 2010 Yale Security Inc., an ASSA ABLOY Group company. All rights reserved.  
 Reproduction in whole or in part without the express written permission of Yale Security Inc. is prohibited.