

SECURITRON MODEL DPA-12 AND DPA-24 DOOR PROP ALARM TIMERS INSTALLATION AND OPERATING INSTRUCTIONS

1. DESCRIPTION

The DPA series consists of a multifunction microprocessor controlled timer. Its primary function is a sophisticated door prop alarm with numerous functions and options that permit tailoring its alarm functions to the specific requirements of the end user. It is available as a circuit board mounted on snap track via the part numbers: DPA-12 and DPA-24. It is also available in a lockable steel enclosure with Sonalert and LED mounted, via the part numbers: BA-DPA-12 and BA-DPA-24. Applications for the DPA series include doors with or without electric locks installed.

2. CIRCUIT BOARD OVERVIEW

Refer to Figure 1. The DPA board consists of five logic inputs, three SPDT relay outputs and four Dip Switches. Two terminals for polarized power input are also provided. The DPA series is available in separate units for either 12 VDC or 24 VDC operation. Note that DC power must be regulated or filtered. **The unit will not operate on pulsating DC (transformer + bridge rectifier).** The 12 volt version draws a maximum of 100 mA and the 24 volt version draws a maximum of 50 mA. These maximums are present when all three output relays are energized.

FIG. 1: CIRCUIT BOARD OVERVIEW

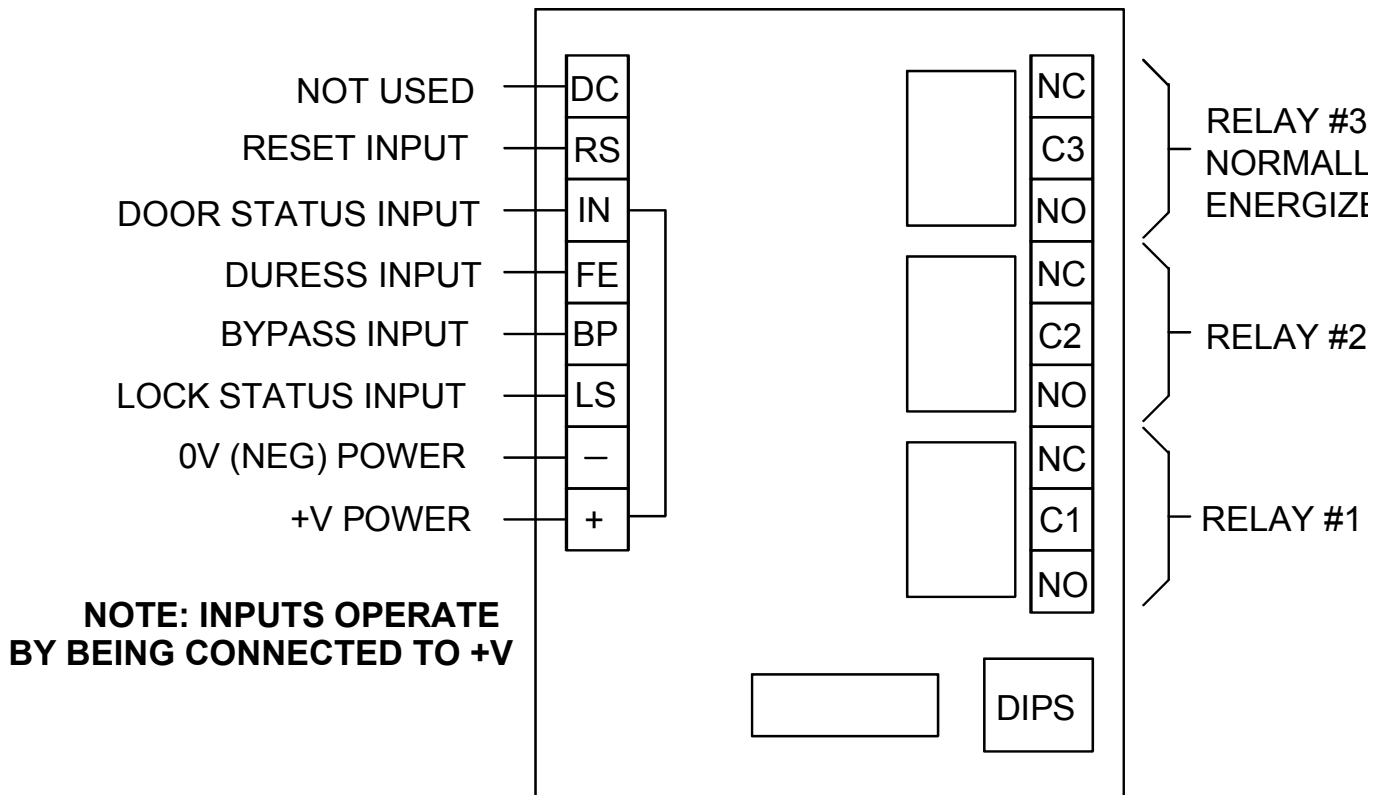

3. BASIC OPERATION

The operation of the DPA occurs in four different stages. The first stage is the **normal condition**. In this stage the door is closed/secure and inputs IN and LS are receiving +V. The output relays are in their normal conditions: relays #1 and #2, deenergized and relay #3, energized.

The next stage is the **authorized condition**. The door opens and **time range one** begins. This range can be digitally set for 30, 60, 120 or 240 seconds. During the authorized condition, the output relays remain in their normal states. The time period selected is the amount of time that the user feels is acceptable for normal door use. Note that it doesn't really matter if the door is electrically locked and employs an access control device or if the door is simply equipped with a panic bar. The central function of the DPA is to prevent doors being propped open too long.

The next stage is **pre-alarm**. If the door has not been reclosed/resecured before the end of the authorized condition (time range one), **relays #1 and #2 energize and time range two begins**. Relay #1 is connected to the Sonalert on the BA-DPA enclosure and the Sonalert will sound at the door. Relay #2 is connected to the LED. Naturally, if you have purchased only the board, it will be up to you how to connect these relays. Time range two can be digitally set for 0, 15, 30 or 60 seconds.

Note that when time range two is set to zero, the pre-alarm condition is eliminated and the board goes directly into the alarm condition at the end of time range one.

The Sonalert sounding at the door during time range two should alert someone in the area to resecure the door before the end of time range two. If this is done, the DPA returns to the normal condition. If time range two expires with the door still not closed/secure, the DPA goes into its final, **alarm** stage.

In the alarm stage, relay #1 follows the door/lock status. If the door is resecured, it will deenergize. Otherwise, it will stay energized. Relay #2 remains energized. In the BA-DPA version, relay #2 operates the LED. This provides a "memory" indication that this particular door is the one which went into the alarm stage. Remember that the Sonalert will stop if the door is reclosed/resecured. In the alarm stage, relay #3 deenergizes which is its alarm condition (relay #3 is normally energized). Relay #3 is normally used to summon building security personnel as in the alarm stage, the door is considered to have been propped open too long. **The reason that relay #3 is normally energized is to provide an alarm signal if power to the DPA is interrupted.** This calls for an alarm signal as the door is no longer being monitored. Note that when you wire relay #3 while referring to Figure 1, **the contacts are labeled in their deenergized condition.** This is the alarm condition as relay #3 is normally energized.

The alarm stage is not limited by time. Recovery consists of resecuring/reclosing the door and then executing a reset. If the door remains propped, reset is not possible. The reset signal can be from a separate switch, such as a keyswitch at the door. This requires security personnel to physically check the door. Alternately, reset can be taken from a door switch so that it will be automatic when the door recloses. Figure 2 shows a graphic representation of basic operation of the DPA, which makes the sequence of operation easier to understand.

FIG. 2: BASIC OPERATION OF THE DPA

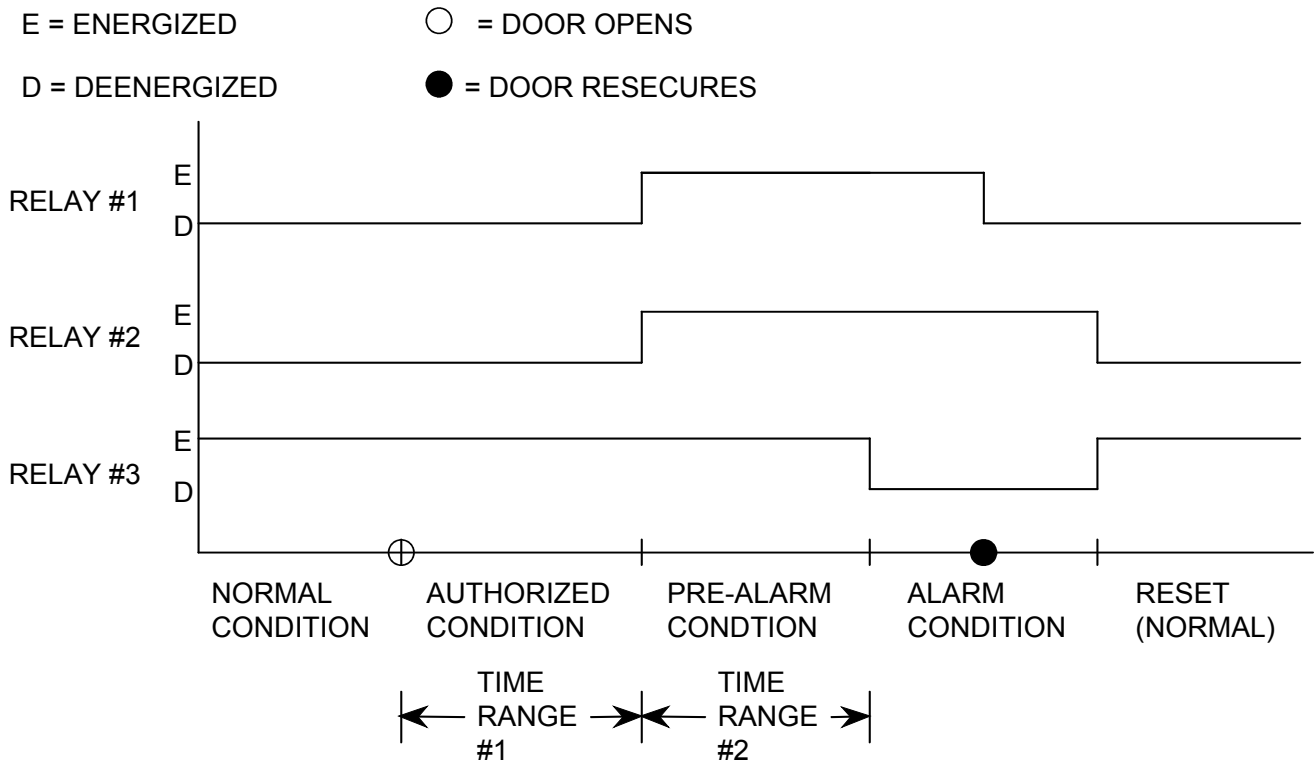

A single graph cannot show all the operating features of the DPA, but Figure 2 does display the basics of the product. Note the events that distinguish between the conditions. The authorized condition begins when the door opens or becomes insecure. Time range one defines the length of the authorized condition unless the door recloses before the end of time range one, in which

case the DPA returns to normal condition. In the pre-alarm condition, relays #1 and #2 begin to signal. The length of this condition is defined by time range two, unless the door recloses before the end of time range two. In that case, again, the DPA automatically returns to the normal condition. The alarm condition during which relay #1 follows door/lock status but relays #2 and #3 are signaling will continue indefinitely until two things happen. First, the door must be resecured and then, the DPA must receive a reset signal.

4. SETTING TIME RANGES 1 AND 2

Note that there are four Dip Switches on the board. They are labeled 1 through 4 and you can also see that they can be set to labeled positions "on" or "off". Dip Switches 1 and 2 allow you to set time range 1 (authorized condition). Dip Switches 3 and 4 set time range 2 (pre-alarm). The following settings allow four choices of time for each range.

TIME RANGE 1

DIP #1-OFF; DIP #2-OFF---30 Seconds

DIP #1-ON; DIP #2-OFF---1 Minute

DIP #1-OFF; DIP #2-ON---2 Minutes

DIP #1-ON; DIP #2-ON---4 Minutes

TIME RANGE 2

DIP #3-OFF; DIP #4-OFF---0 Seconds

DIP #3-ON; DIP #4-OFF---15 Seconds

DIP #3-OFF; DIP #4-ON---30 Seconds

DIP #3-ON; DIP #4-ON---1 Minute

5. WIRING FOR DOOR STATUS AND LOCK STATUS

Earlier in this manual, we have talked about the door being open or insecure interchangeably. In fact these are two separate conditions and the DPA handles them in a sophisticated way which includes a unique type of tampering detection.

There are various means of detecting the status of a door. The most common is a magnetic door switch. This activates when the door opens an inch or so. It says nothing about whether the door is secure or not. In that sense, it is the poorest type of door status detection. If the door is an unlatched swing through type, however, a magnetic door switch is the only device that can be used.

When the door includes a latch, it is possible to detect the presence of the latch in the strike by use of a "monitoring strike". This component includes a microswitch which is activated by the presence of the latch. Latch detection is superior to door position detection because it confirms that the latch is engaged. Many doors that employ DPA's include a panic bar or exterior locked knob set which permits free egress but not entry. Latch detection in this instance qualifies as lock status detection as it shows that the door is secure against entry.

Electrically locked doors often allow lock status detection. If an electric strike is mounted, some models include a signal to show that the latch is engaged. Electromagnetic locks generally offer lock status detection as an option. Securitron's Senstat Magnalocks are an example.

The issue for use of the DPA is whether you wish to use one signal for initiating the functions or two. The advantages of using one are lower costs and simplicity. The advantages of using two are higher security against tampering as will be explained shortly. When you are using a single door status signal to activate the DPA, select the highest security signal that you have available. Lock status is better than door status. **Regardless of the signal selected, however, it must be input to terminal LS and the factory installed jumper between terminal "+" and terminal IN must be left in place.** Terminal IN can never be used as the only input to activate the unit. It can only be used in concert with terminal LS.

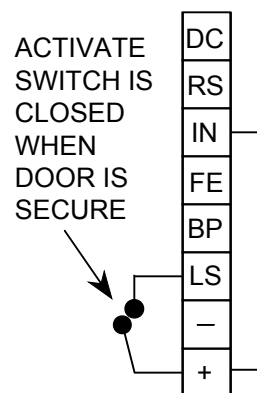

Note the drawing on the right. The jumper is correctly installed between IN and "+". The door status or lock status switch is installed between "+" and LS so that it is closed when the door is secure. The DPA will start its timing functions when this switch opens so that +V is no longer being fed to terminal LS. Note that if you are using Securitron's "S" Senstat Magnalock at the door, it provides a direct +V status signal on its white wire. You need only connect the Magnalock's white wire to terminal LS.

5.1 FORBIDDEN CONDITION DETECTION

If you have both a door status switch and lock status switch available, you can employ the DPA in a higher security mode that includes a unique type of tamper detection. To understand this feature, you must first think about how a lock status switch and door status switch work together. We know a door can be closed but not necessarily locked. So it's possible for a door status switch to be reporting secure while a lock status switch is reporting insecure. The opposite, however, is not possible. A door cannot be reporting locked from its lock status sensor and yet reporting physically open from its door status sensor. We call this the "forbidden condition". The only way that such an event could happen (assuming the status switches have not failed) is if someone tampered with the lock status sensor to make it read secure regardless of the true state of the lock.

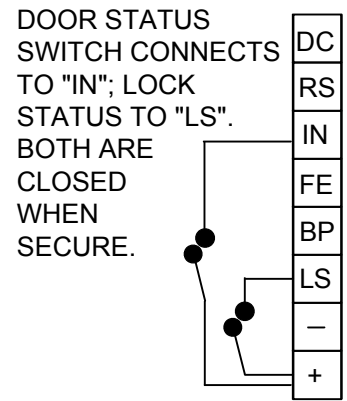

This exact problem is a very real security risk. Consider the case of a monitoring strike which detects the presence of a panic bar latch in the strike. This is a type of lock status detector. An individual can easily stuff material into the strike which will jam the switch down so that the lock status sensor "thinks" the latch is secure and in place when its not. He then is free to use the door later without creating an alarm. More sophisticated lock status sensors such as are available as options on electric locks can also be fooled, although with more difficulty. One way is to gain access to the wiring and short it. Another way with magnetic locks (for instance) is to manage to cut the strike plate's mounting to the door so that the magnet is holding the strike plate but the door is still free to open.

When you connect a door status switch to terminal IN and a lock status switch to terminal LS, the DPA automatically monitors any occurrence of this forbidden condition. **Be sure to remove the factory jumper from "+" to IN.** The lock status line will have been tampered so as to falsely report secure but when the door opens and this is reported to the DPA via the door status sensor, the board will go into instant alarm as follows:

Relay #1 will energize so long as the door is open. This will sound the local alarm

Relay #2 will "flash" twice per second

Relay #3 will change state

This dramatic alarm signal is a latching condition. To recover from it, the door must first be reclosed and then the unit given a reset input. Security personnel should then investigate to determine if tampering with the lock sensor has occurred. The fastest way to do this is simply to open the door a second time. It can then be checked if the problem is tampering or failure of the status sensing components.

6. RESET

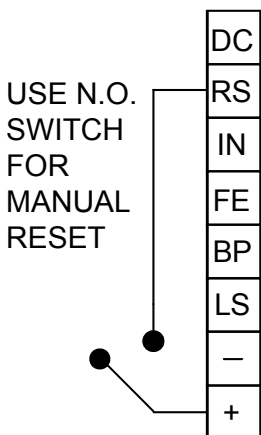

We have talked about "resetting" the DPA several times earlier in this manual. Reset recovers from two latching alarm conditions: the standard fourth stage condition at the end of time range two and the special forbidden condition alarm signal (see Section 4.1). The board will receive a reset signal when +V is input to terminal RS.

There are two different approaches to the reset function. The first is with a separate switch. This is often a keyswitch at the door with N.O. contacts connected between "+" and RS. The advantage of this is that once the unit has gone into latching alarm, an authorized person with a key is required to go to the door and personally verify that no security problem is occurring.

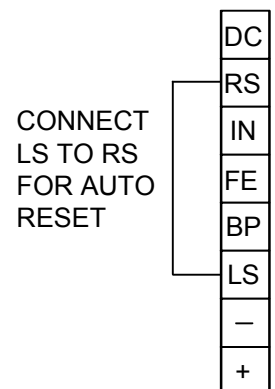

If such a person is not available, the DPA can be wired for a type of automatic reset. Simply connect terminals RS and LS together. Since LS has power on it when the door is secure, RS will too. When the door becomes insecure, the board will begin to go through its timing stages and RS will have no power on it. If the fourth latching alarm stage is reached, recovery is by

closing or resecuring the door. The act of doing this will send a +V reset input to RS and reset will be accomplished automatically.

It's worth noting that wiring for auto reset has an effect on forbidden condition detection. When you have made connections to both lock status and door status signals, a forbidden condition alarm will be given instantly if, at any time, the door reads open while the lock reads secure. The condition will reset itself immediately when the door recloses as lock status and reset are tied together and are both continuously sending +V to their respective inputs. To summarize, when auto reset is wired, a forbidden condition alarm also auto resets.

7. BYPASS AND DURESS

These are strictly optional functions. The DPA will be bypassed when +V is input to terminal BP. As long as this connection is maintained, the board will retain its relays in the normal state and will ignore all other inputs. **Note that bypass can only be accomplished when the DPA is in the normal or authorized condition.** Bypass cannot be used to terminate other alarm functions in progress. **Duress and forbidden condition detection also operate while the board is bypassed,** as responding to these events is vital for security.

The purpose for bypass is to deactivate the DPA during times when the door can be propped. This is usually a time of day issue and the bypass input can be activated by a time clock signal. A question that is sometimes raised is why not simply unpower the board to take it out of service. This will not work because relay #3 is in a normally energized state and when power is removed to the DPA, it will deenergize which will be read as an alarm signal.

Duress is an optional instant alarm function. When +V is momentarily input to terminal FE, all three relays begin to pulse every three seconds. **A duress signal will always override any other state the DPA is in (including bypass).** This is a latching condition which is **not** recovered from by the board receiving the normal reset input. To recover from the duress condition, a momentary bypass input must be received (terminal BP). The reason for providing a different input to reset duress is that the normal reset input (terminal RS) may be connected to door or lock status in the automatic reset function.

The duress function can be used to signal real duress. A momentary "panic" push button can be mounted near the door which allows anyone to signal if they require assistance. In this situation, it makes sense to have a keyswitch at the door which operates the bypass input. An authorized person will come to render assistance and to clear the duress alarm signal. Since the DPA will also be operating its standard door prop alarm functions, it should be noted that it will cause no harm if the same keyswitch momentarily operates the reset and bypass input together. Thus one keyswitch will be able to clear all latching alarm conditions. Remember that momentary use of the bypass input does not interfere with any other functions. The DPA is bypassed only when the bypass input is **maintained** and the board is in the normal or authorized condition at this time.

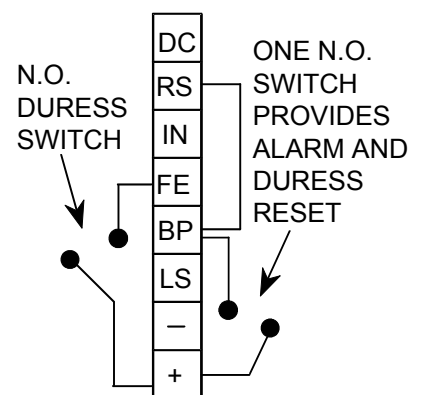

8. TIME CONTROLLED INSTANT ALARM

Applications often exist where the DPA operates as a two stage door prop alarm during the day only. At night the affected door is not to be used, so an instant latching alarm from the DPA is desired. By using a time clock such as Securitron's model DT-7, this can be achieved in either of two ways.

The duress input can be used. A signal must be made available which closes when the door opens. During the day the time clock relay blocks this closure with open contacts. At night, the time clock relay contacts close and any time the door is opened, the DPA goes into immediate duress alarm mode. This does require the bypass input to clear the alarm condition as is described in section 6.

An alternate technique can be employed for installations where both lock status and door status signals are being input to the DPA. At night, the time clock relay closes across the lock status input keeping it reporting secure. Any time the door opens, the board immediately reads the forbidden condition and goes into instant alarm. Recovery is by reclosing the door and sending a reset input to the DPA. We prefer the use of the duress input as using the forbidden condition technique reduces the security of the door. If, for example, the lock failed to engage, this would not be reported as the time clock shunts this signal at night.

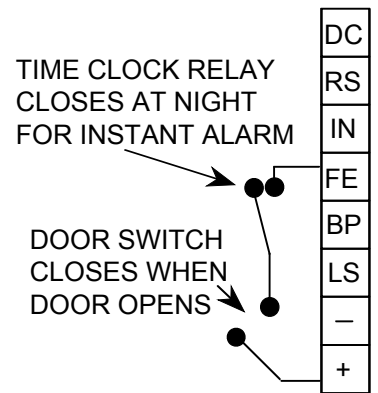

9. COMPLETE WIRING EXAMPLE

Figure 2, on the next page, provides one example of complete wiring for a DPA board. Because of the unit's power and flexibility, many different wiring schemes are possible. Showing and discussing one complete example, however, helps clarify use of the product.

In this application, we are using one of Securitron's "S" Sentat Magnalocks, which secures the door. Note that we do not show the power and control connections for the Magnalock because they have nothing to do with operation of the DPA. The DPA's role is only to monitor the secure status of the Magnalock and this is done by simply connecting the lock's white wire to terminal LS. This wire has +V on it when the lock is secure.

We also wish to detect any forbidden condition violation so we have added a door switch which is closed when the door is closed. The switch common is powered by +V and the other side connects to terminal IN. Reset is via a momentary normally open switch which connects into terminal RS. For this application we want to occasionally disable the board, so we have an alternate switch connected to terminal BP. We are not using duress so there is no connection to terminal FE.

On the output side, we are showing the use of a Sonalert powered by relay #1 and an LED powered by relay #2. This is exactly the way the unit is prewired when you buy the BA-DPA version. If you have bought just the DPA version, you are free to use the same audio and visual signals or create your own output reporting scheme. Relay #3 is typically employed for remote monitoring into an alarm system or powering another remote light or sounder.

FIG. 2: COMPLETE WIRING EXAMPLE

