

ASSA ABLOY

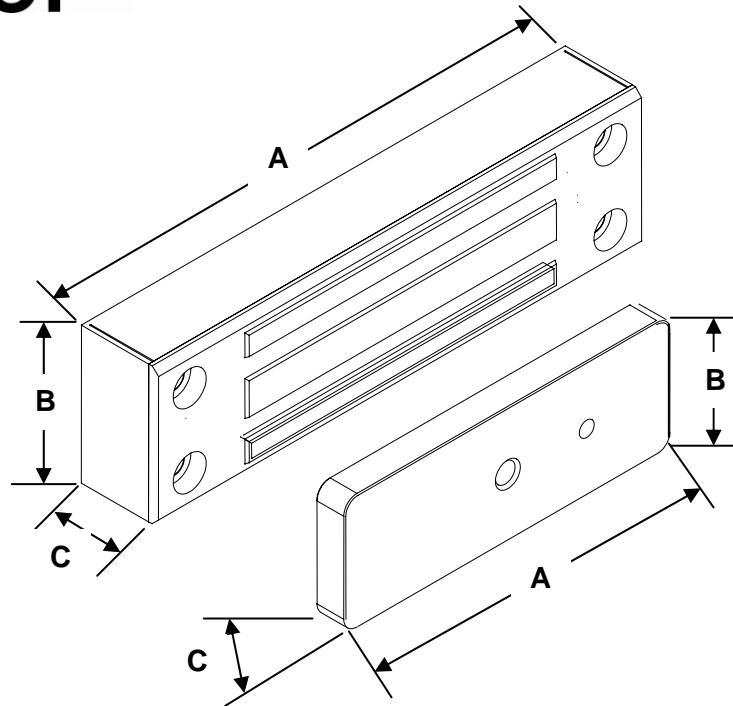

MODEL	A	B	C	MODEL	A	B	C
MCL-24 LOCK	4.625	1.14	0.75	MCL-24 STRIKE	3.1	1.1	0.25

MAGNETIC CABINET LOCK - MODEL MCL-24:

Features

- Fail safe
- Fits in most size limited applications
- Unlimited operating life
- Suitable for outdoor use
- 200 lbs. holding force
- Low current draw (62 mA @ 24VDC)
- All ferrous metal surfaces plated to MIL specification
- Operating environment -40F to 140F [-40C to 60C]
- 10 ft cable included
- Self aligns to operate reliably
- Fail Safe



Operating Temperature

-40 to 60 C [-40 to 140 F]

MAGNETIC CABINET LOCK - MODEL MCL-24 (cont'd)**How to Order**

<u>Part #</u>	<u>Description</u>
MCL-24	Magnetic Cabinet Lock 24VDC

Architectural Specifications

- A. The MCL-24 Magnetic Cabinet Lock shall be produced by an ISO 9001 certified manufacturer
- B. The Magnetic Cabinet Lock shall have a limited lifetime warranty covering malfunction and abuse.
- C. The LOCK shall only be available in a 24VDC model.
- D. The LOCK shall be fail safe and fit into most size limited applications.
- E. The LOCK shall have 200 pounds of holding force and shall provide a strong level of security for cabinet locking applications.
- F. The LOCK shall support outdoor use or use where the cabinet will be released for extended periods of time.