



VR910/VR914

IVES

829654-00

Vandal Resistant Trim for use with Rim and Vertical Devices

Installation Instructions

1 Prepare push side of door for exit device.

See exit device instructions for preparation.

2 Prepare pull side of door for trim.

2a Transfer vertical and horizontal device center lines from push side of door to pull side.

2b Locate and prepare all holes as indicated below.

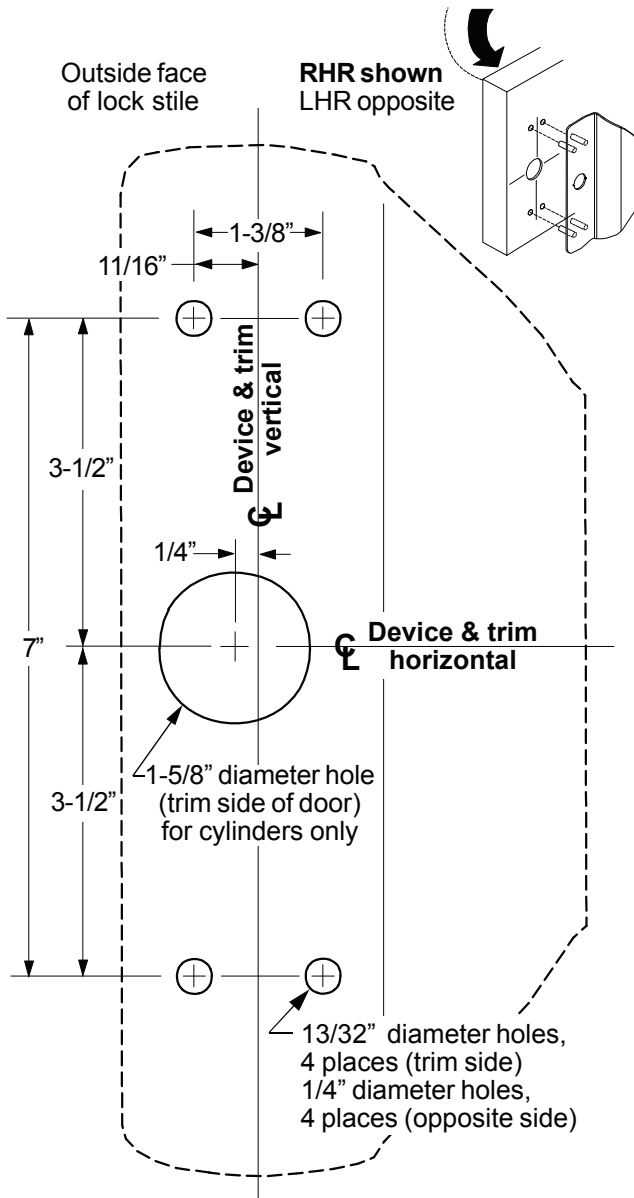

3 If using a cylinder:

3a Secure cylinder to trim.

3b Place trim on door and cut cylinder tailpiece so it projects 1/2" out of door.

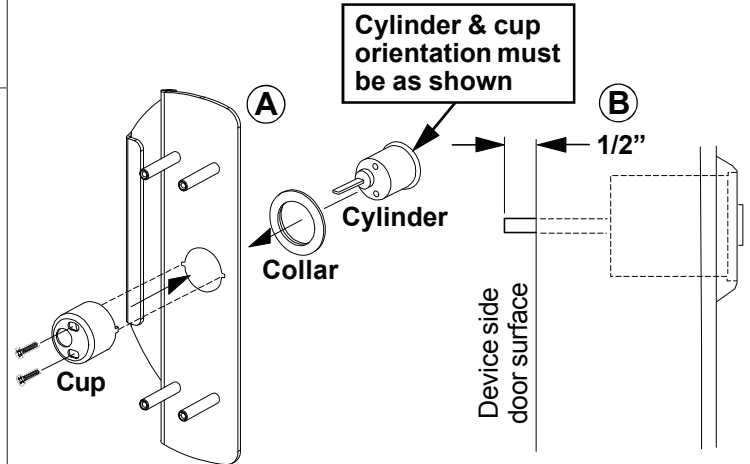

4 Install exit device and trim (install tailpiece guide if using a cylinder).

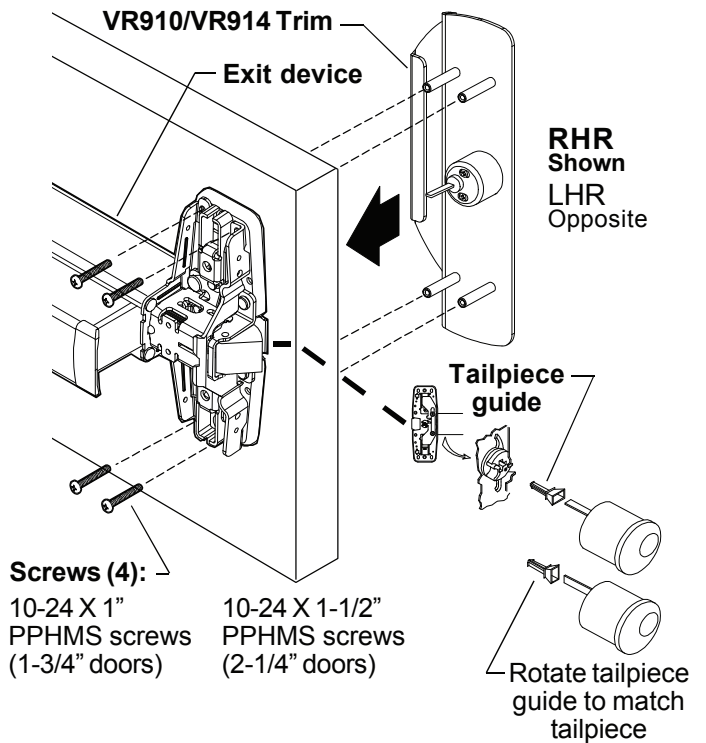

Customer Service

1-877-671-7011

www.allegion.com



© Allegion 2014
Printed in U.S.A.
829654-00 Rev. 01/14-b