

LOCK INTO THE ACSI ADVANTAGE

M1500M Motor Drive Mortise Lock Series

Features

- Simple user selectable fail safe/fail secure operation from outside of the lock body
- Automatic 12V or 24V, AC or DC operation
- Low current draw
- UL and cUL Listed
- California State Fire Marshall approval

Options

- Authorized Egress (Request-to-Exit)
- Latchbolt Monitor
- Door Position Switch
- Deadbolt Monitor
- Deadbolt Monitor Secure
- Security Monitor
- Locking of Both Levers
- ASSA or Allegion quick-connect cables available

Technical Specifications

- 10.8V - 26.4V Operating Range
- 250mA MAX Inrush
- 10mA MAX Holding
- Non-polarized Leads

SCHLAGE L9000 SERIES

CORBIN ML2000 SERIES
ARROW AM, BM SERIES

HAGER 3800 SERIES

SARGENT 8200 SERIES
YALE 8800 SERIES

DESIGN HARDWARE
M SERIES
FALCON MA SERIES

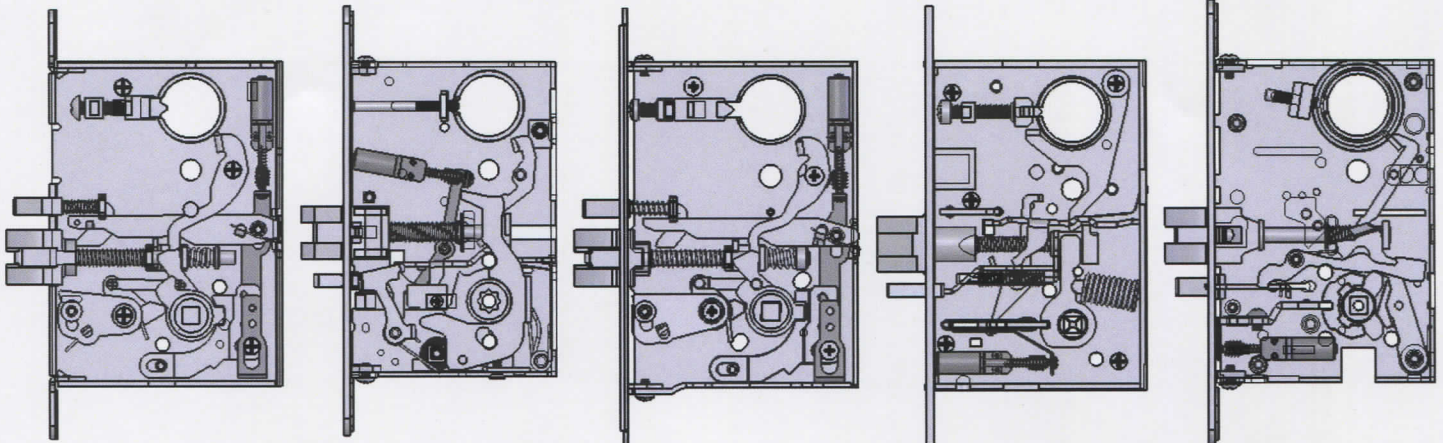

For more information contact the factory at 1-800-753-5558 or visit www.acsi-inc.com

2720 CLARK AVENUE • SAINT LOUIS, MO, 63103 • 314/652-5588 • FAX 314/652-2090 • 800-753-5558 • WWW.ACSI-INC.COM