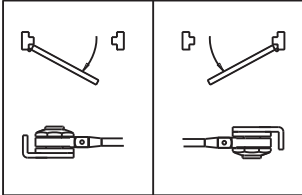
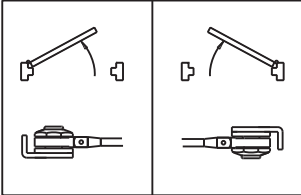
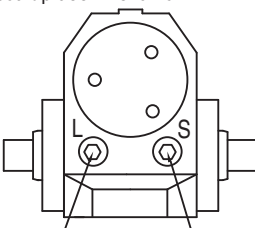
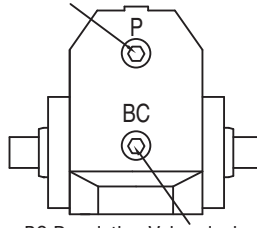

DOOR CLOSER

HOLD OPEN ARM (FRICTION TYPE)

INSTALLATION INSTRUCTIONS

Chart To Determine Orientation of Foot

<p>Optional Hold-open Arm</p> <p>Identify direction of hold-open nut according to mounting.</p> 	<p>Optional Hold-open Arm</p> <p>Identify direction of hold-open nut according to mounting.</p> 	<p>Regulating Door Speed And Latching Speed</p> <p>Turn speed regulating valve clockwise to slow down or counter clockwise to speed up door movement.</p>  <p>This valve controls Latching Speed This valve controls Door Sweep Speed</p>	<p>Regulating Spring Power Regulating BC Power</p> <p>Turn power adjustment screw clockwise to increase or counter clockwise to decrease.</p>  <p>Turn BC Regulating Valve clockwise to increase or counter clockwise to decrease. NEVER close completely.</p>
--	--	---	--

Standard Installation: Pull Side Right Installation

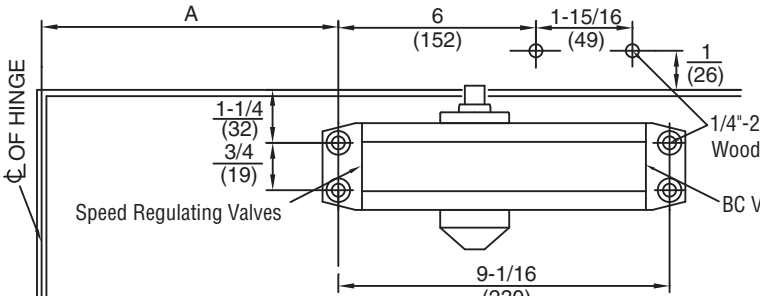

DIMENSIONS "A"		OPENING
inches	mm	
7	178	TO 100°
6	152	101° TO 120°
3-1/2	89	*121° TO 180°

- Right hand door illustrated. Same dimensions apply to left hand door.
- Measured from hinge centerline. Dimensions are in inches (mm).
- Do not scale drawing.

*Door/Wall/Hardware/Jamb conditions permitting

INSTALLATION INSTRUCTIONS

1. Select degree of door opening. Use dimensions shown in chart to mark location of attaching screws on door and frame. Prepare holes.
2. Assemble main arm to closer.
3. Attach closer to door with speed regulating valves toward hinge.
4. Attach the foot of the forearm to frame.
5. Adjust length of forearm to position forearm at right angle to frame. Tighten the screw of forearm.
6. Snap pinion cap over pinion at bottom of closer.
7. Adjust closer.
8. Loosen the inner hex screw at the elbow of the forearm. Open the door to the angle you need. Tighten the inner hex screw to hold the door open.

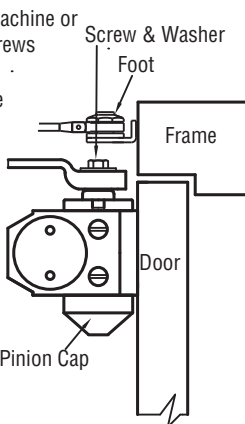

Position Of Arms And Index Settings

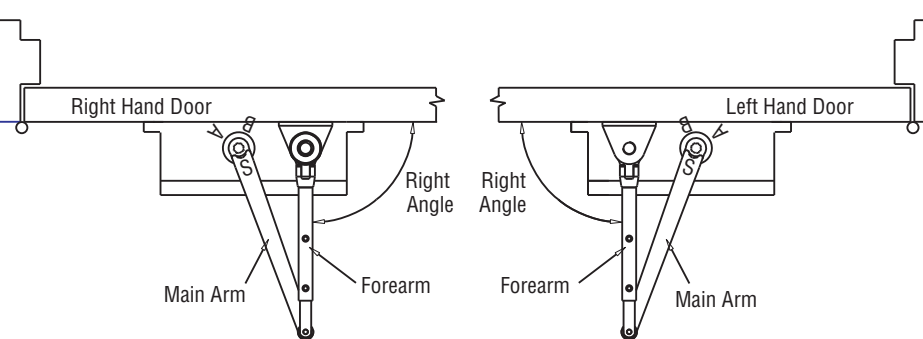

Closing Speed Control

CAUTION: DO NOT BACK VALVES OUT OF CLOSER OR A LEAK WILL RESULT

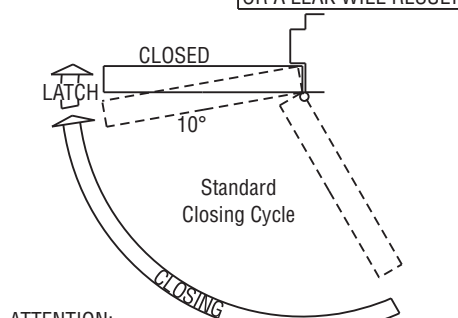

ATTENTION:
Adjust closing speed time to between 4 to 6 seconds from 90°. Use of the door by handicapped, elderly or small children may require longer closing time.

Other Installation: Push Side Top Jamb Installation

INSTALLATION INSTRUCTIONS

1. Select degree of door opening. Use dimensions shown in chart to mark location of attaching screws on door and frame. Prepare holes.
2. Assemble main arm to closer.
3. Attach closer to frame with speed regulating valves toward hinge.
4. Attach the foot of the forearm to door.
5. Adjust length of forearm to position forearm at right angle to frame. Tighten the screw of the forearm.
6. Snap pinion cap over pinion at bottom of closer.
7. Adjust door closer.
8. Loosen the inner hex screw at the elbow of the forearm. Open the door to the angle you need, then tighten the inner hex screw to hold the door open.

DIMENSIONS "A"		OPENING
inches	mm	
7-1/2	191	TO 100°
6	152	101° TO 120°
3-1/2	89	*121° TO 180°

*Door/Wall/Hardware/Jamb conditions permitting

- Left hand door illustrated. Same dimensions apply to right hand door.
- Measured from hinge centerline. Dimensions are in inches (mm).
- Do not scale drawing.

Other Installation: Push Side Parallel Installation

INSTALLATION INSTRUCTIONS

1. Select degree of door opening. Use dimensions shown in chart to mark location of attaching screws on door and frame. Prepare holes.
2. Attach closer to door with speed regulating valves away from hinge.
3. Attach Main arm as follows:
 - a. Place open end wrench on bottom shaft & turn toward hinge about 30°.
 - b. Place Main arm on top shaft, insert arm screw into top of shaft and tighten.
4. Attach PA Plate to top of frame as shown.
5. Fasten forearm to PA Plate.
6. Adjust length of forearm to position Main arm parallel to frame. When connected to main arm at elbow, use washer and screw provided to secure pivot connection. Tighten locknut of forearm.
7. Snap pinion cap over pinion at bottom of closer.
8. Loosen the inner hex screw at the elbow of the forearm. Open the door to the angle you need, then tighten the inner hex screw to hold the door open.

DIMENSIONS "A"		DIMENSIONS "B"		OPENING
inches	mm	inches	mm	
9	227	7-5/8	194	TO 120°
7-1/2	190	6-1/8	156	*121° TO 180°

*Door/Wall/Hardware/Jamb conditions permitting

- Right hand door illustrated. Same dimensions apply to left hand door.
- Measured from hinge centerline. Dimensions are in inches (mm).
- Do not scale drawing.

APPLICABLE DOOR: Weight 44-176 lbs (20-80Kg)