

6000 SERIES TRIM MOUNTING HOLE DOOR PREP FOR VERTICAL MOUNTING ONLY BACKSET DISTANCES 2-3/4 TO 5"

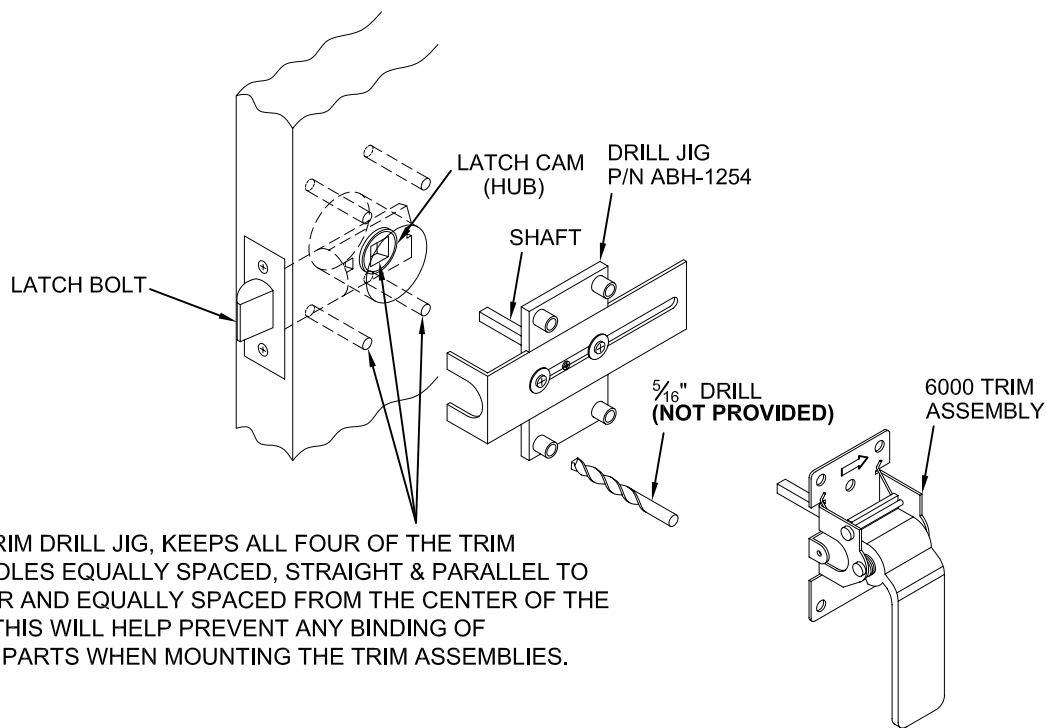

USING THE TRIM DRILL JIG, KEEPS ALL FOUR OF THE TRIM MOUNTING HOLES EQUALLY SPACED, STRAIGHT & PARALLEL TO ONE ANOTHER AND EQUALLY SPACED FROM THE CENTER OF THE LATCH CAM, THIS WILL HELP PREVENT ANY BINDING OF MECHANICAL PARTS WHEN MOUNTING THE TRIM ASSEMBLIES.

INSTRUCTIONS:

1. DETERMINE AND LOCATE THE HORIZONTAL CENTERLINE HEIGHT OF THE 6000 PUSH/PULL LATCH TRIM OR MATCH THE HEIGHT OF THE HORIZONTAL CENTERLINE OF THE EXISTING STRIKE..
2. IF THE DOOR WILL HAVE AN EDGE GUARD OR OTHER DEVICE THAT MAY BE MOUNTED ON THE DOOR EDGE THIS MAY AFFECT HOW THE LATCH IS MOUNTED. REFER TO THE EDGE GUARD NOTE ON THE 6000 PUSH/PULL LATCH TEMPLATES ON HOW TO DETERMINE BACKSET.
3. PREP THE DOOR FOR THE LATCH. SEE 6000 PUSH/PULL LATCH TEMPLATE.
4. INSTALL THE LATCH. HAVING THE LATCH INSTALLED HELPS SUPPORT AND KEEP THE DRILL JIG IN IT'S PROPER LOCATION.
5. LOOSEN THE (2) PHILLIPS HEAD SCREWS ON THE DRILL JIG TO ALLOW THE "L" BRACKET TO SLIDE.
6. PLACE THE JIG ON EITHER SIDE OF THE DOOR WITH THE SQUARE SHAFT INSERTED THROUGH THE LATCH CAM (HUB) AND THE SHORT LEG OF THE "L" BRACKET STRADDLING THE LATCH BOLT AND AGAINST THE EDGE OF THE DOOR. **MAKE SURE THE DRILL JIG IS LEVEL WITH THE LATCH AND FLAT AGAINST THE DOOR.** TIGHTEN THE (2) PHILLIPS HEAD SCREWS.
7. USING A 5/16" DRILL (**NOT PROVIDED**), DRILL THE FOUR TRIM MOUNTING HOLES. FOR HOLLOW METAL DOORS, DRILL (4) HOLES ON ONE SIDE OF DOOR. DO **NOT** DRILL THROUGH. PLACE JIG ON OPPOSITE SIDE OF DOOR AND DRILL (4) HOLES.
8. REMOVE DRILL JIG AND MOUNT TRIM. SEE 6000 PUSH/PULL LATCH TEMPLATES FOR DETAILS.

PATENT PENDING



® www.abhmfg.com

E-mail: abhinfo@abhmfg.com

Architectural Builders Hardware Mfg., Inc.

1222 Ardmore Ave., Itasca, IL 60143

630.875.9900; FAX 800.9FAXABH (932.9224)

DISTRIBUTED BY



© 2006 ABH Mfg., Inc.
printed in USA

6000 DRILL JIG DOOR PREP-03.DWG

6000 JIG

REVISED 08-29-06