

Half Surface & Full Surface

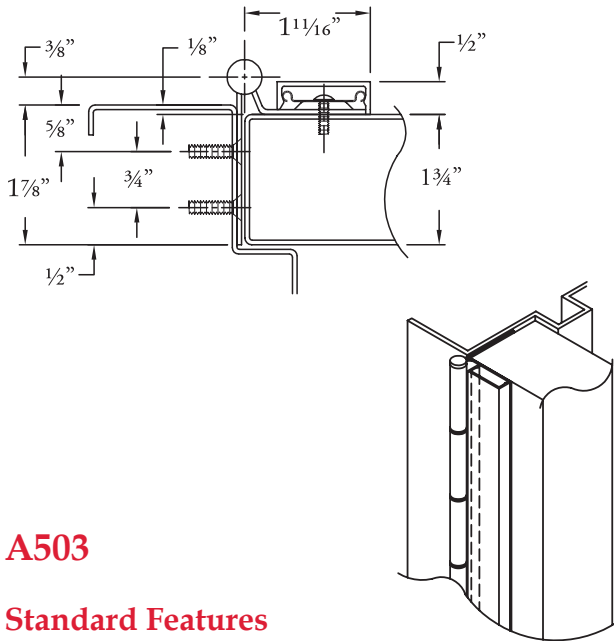

A503

Standard Features

- Half surface, heavy duty
- 1/8" door inset
- 48" door width maximum
- 600 lbs. door weight maximum
- Door leaf fastener cover is clear anodized aluminum
- **Fasteners:** 10-24 x 7/8" undercut, self-drilling, thread-forming tek machine screws, stainless steel for frame and 1/4-20 x 3/4" round head self-drilling tek machine screws, zinc plated for door
- **Lengths:** 78-3/4", 83-1/8", 85", 95" and 118-3/4"
- **Finishes:** US32D Satin Stainless Steel or US32 Bright Stainless Steel
- **Fire Rating** - tested and certified by UL® (U.S.A. and Canada) on 4'0" x 10'0" fire rated doors, based on the following
 - 20 minutes - wood doors
 - 90 minutes - hollow metal and composite core wood fire doors
 - 3 hours - hollow metal doors

Options Available

- See pages G-6 to G-7 for modification availability and details

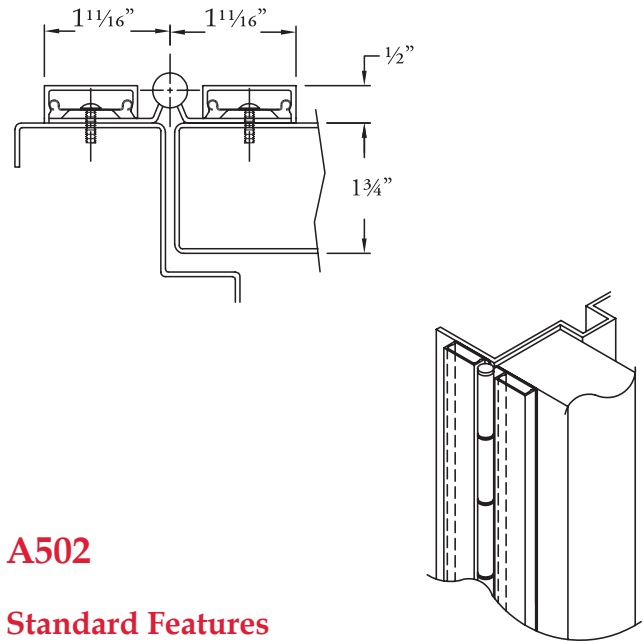

A502

Standard Features

- Full surface, heavy duty
- No door inset, flush mount
- 48" door width maximum
- 600 lbs. door weight maximum
- Frame and door leaf fastener covers are clear anodized aluminum
- **Fasteners:** 1/4-20 x 3/4" round head self-drilling, thread-forming tek machine screws, zinc plated
- **Lengths:** 78-3/4", 83-1/8", 85", 95" and 118-3/4"
- **Finishes:** US32D Satin Stainless Steel or US32 Bright Stainless Steel
- **Fire Rating** - tested and certified by UL® (U.S.A. and Canada) on 4'0" x 10'0" fire rated doors, based on the following
 - 20 minutes - wood doors
 - 90 minutes - hollow metal and composite core wood fire doors
 - 3 hours - hollow metal doors

Options Available

- See pages G-6 to G-7 for modification availability and details

DISTRIBUTED BY

